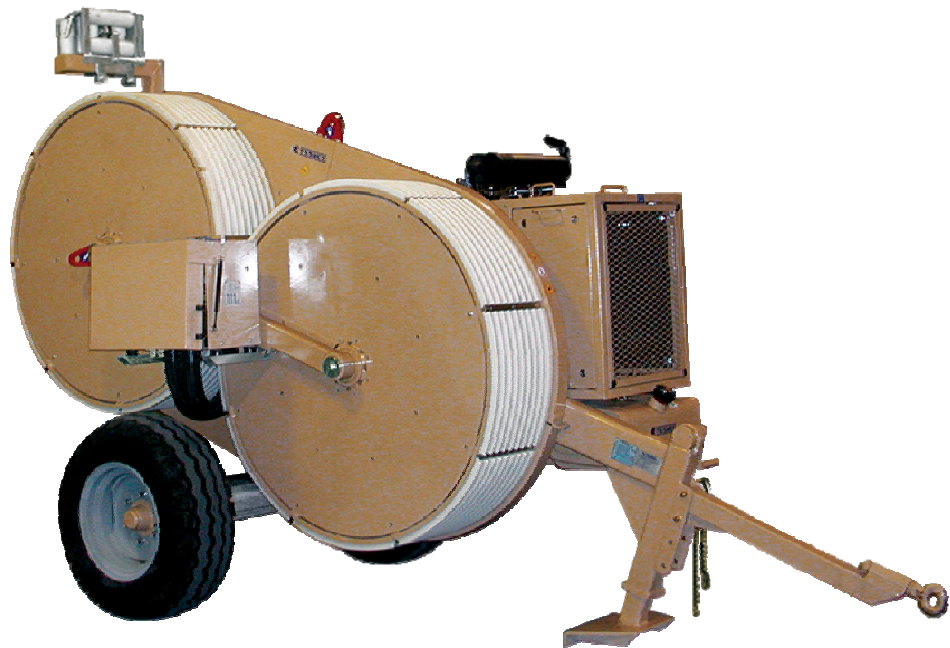


**Installation, operation and  
maintenance**

**Handbook**



Puller-Tensioner Model: **AFS404**

## ATTENZIONE

Per motivi di sicurezza durante il trasporto la macchina è fornita senza olio idraulico e senza carburante. Nel presente fascicolo troverete informazioni sulle caratteristiche e le quantità richieste. In caso di dubbio consultare la TESMEC.

## WARNING

The machine is supplied without hydraulic oil and fuel during transport for precautionary measures. Please refer to this manual for all information regarding the characteristics and quantities required. Should you have any doubt, please get in touch with TESMEC.

## ATTENTION

Pour mesures de sécurité, pendant le transport la machine est livrée sans huile hydraulique et sans carburant.

Référez-vous à ce manuel pour renseignements nécessaires sur les caractéristiques et quantités. En cas de doute veuillez contacter TESMEC.

## ATENCION

Por motivos de seguridad la máquina se transporta sin aceite hidráulico y sin combustible. En el presente fascículo encontrarán informaciones acerca de las características y de las cantidades requeridas. En caso de dudas, consultar a TESMEC.

## ATENÇÃO

Por razões de segurança durante o transporte, a máquina é fornecida sem óleo hidráulico e combustível. No presente folheto poderão encontrar as informações sobre as características e as quantidades requeridas.

Caso tenham alguma dúvida, rogamos-lhes pôr-se em contacto com a TESMEC.

## ACHTUNG

Aus Sicherheitsgründen während des Transportes, wird die Maschine ohne Öl und Kraftstoff geliefert. Im vorliegenden Gebrauchsanweisungsheft werden Sie Informationen über die Eigenschaften und Mengen des Öls finden.

Wenn Sie im Zweifel sind, fragen Sie TESMEC um Rat.

## ПРЕДУПРЕЖДЕНИЕ

Из соображений безопасности, при поставке машина транспортируется без рабочей жидкости в гидравлической системе и топлива.

Пожалуйста, пользуйтесь настоящим руководством для получения любых сведений, касающихся характеристик и заправочных емкостей.

В случае каких-либо сомнений, пожалуйста, свяжитесь с компанией TESMEC.



- 24050 Grassobbio (Bg) via Zanica, 17/O  
Tel. 0039 / 035 / 4232911  
Telefax 0039 / 035 / 4522445  
E-mail: info@tesmec.it

- 24060 Endine Gaiano (Bg) via Pertegalli  
Tel. 0039 / 035 / 825024  
Telefax 0039 / 035 / 826375  
E-mail: info@tesmec.it

# ***PULLER-TENSIONER***

## ***Model: AFS404***

*Serial number*

.....

*Manufacturing year*

.....

*Working order*

.....

**USE AND MAINTENANCE INSTRUCTIONS**



## 1. GENERAL INDEX

	<i>Page</i>
<b>1. GENERAL INDEX</b>	<b>1</b>
<b>2. GENERAL DATA AND PRESCRIPTIONS</b>	<b>3</b>
2.1 MANUFACTURER	3
2.2 COMMUNICATIONS WITH THE MANUFACTURER	3
2.3 TYPOLOGY AND USING FIELD	3
2.4 PERFORMANCES	3
2.5 TECHNICAL CHARACTERISTICS	4
2.6 ACOUSTIC EMISSION	4
2.7 GENERAL INFORMATION FOR THE MACHINE USE	4
2.8 GENERAL PRESCRIPTIONS FOR THE OPERATOR CHARGED OF THE MACHINE USE	4
2.9 GENERAL PRESCRIPTIONS FOR THE OPERATOR CHARGED OF THE MACHINE	4
MAINTENANCE	5
2.10 KNOWLEDGE AND CARE OF THE INSTRUCTION MANUAL	5
2.11 CONDITION OF USE	5
2.12 TEMPERATURE LIMITS FOR HYDRAULIC OIL	6
2.13 USE NOT ALLOWED	6
2.14 RESPONSIBILITY	7
2.15 APPLIED NORMS	7
<b>3. TRANSPORT AND POSITIONING INSTRUCTIONS</b>	<b>8</b>
3.1 MACHINE LIFTING	8
3.2 TRANSPORT TYPOLOGIES AND PACKAGE	8
3.3 UNPACKING	8
3.4 ASSEMBLING OPERATIONS	9
3.5 TRANSPORT ON TRAILER	9
3.6 POSITIONING AND ANCHORING	9
<b>4. INSTRUCTION FOR USE</b>	<b>11</b>
4.1 PRESCRIPTIONS FOR THE OPERATOR	11
4.2 CONTROLS	11
4.3 PRELIMINARY OPERATIONS	11
4.4 MACHINE SET-UP	12
4.5 ELECTRONIC MULTIFUNCTION DAVICE PAGES	13
4.6 STARTING OF THE MACHINE	15
4.7 PULL CONTROL	15
4.7.1 PULL LIMITING DEVICE SETTING	15
4.7.2 PULL PROGRAMMING DEVICE SETTING	16
4.8 CONNECTION MACHINE-HYDRAULIC HEAD OF THE REEL ELEVATOR OR REEL WINDER	17
4.9 PULLING OPERATIONS	17
4.10 RELEASING THE ROPE	18
4.11 COMPRESSOR CONNECTION (OPTIONAL)	18
4.12 PREHEATING KIT (OPTIONAL)	19
4.13 PREHEATING CONTROL PANEL PROGRAMMING (OPTIONAL)	19
4.13.1 GENERAL (OPTIONAL)	19
4.13.2 OPERATION (OPTIONAL)	19
4.13.3 SWITCHING THE HEATER ON (OPTIONAL)	20
4.13.4 SWITCHING THE HEATER OFF (OPTIONAL)	20
4.13.5 SETTING TIME/DAY OF THE WEEK (OPTIONAL)	20
4.13.6 VIEWING THE TIME (OPTIONAL)	20
4.13.7 PROGRAMMING HEATER STARTING TIME (OPTIONAL)	20
4.13.8 RECALLING/ERASING PRE-SET TIMES (OPTIONAL)	20
4.13.9 PROGRAMMING DURATION OF OPERATING TIME (OPTIONAL)	20
4.13.10 SETTING THE REMAINING OPERATING TIME (OPTIONAL)	20
4.13.11 SETTING THE WAKEUP TIME (OPTIONAL)	20
4.13.12 RECALLING/ERASING THE WAKEUP TIME (OPTIONAL)	21
4.14 ROPE LOCKING CLAMP (OPTIONAL)	21
4.15 POINTS TO REMEMBER	21

4.16	END OF THE OPERATIONS	21
<b>5.</b>	<b>INSTRUCTION FOR USE – CONNECTED MACHINES</b>	<b>22</b>
5.1	GENERAL ASPECTS	22
5.2	MACHINES SET-UP	23
5.3	CONNECTED MACHINES OPERATIONS	24
5.4	PULL CONTROL SETTING	24
5.4.1	PULL LIMITING DEVICE SETTING	24
5.4.2	PULL PROGRAMMING DEVICE SETTING	24
5.5	USING OF ELECTRONIC SPEED SYNCHRONIZER DEVICE (OPTIONAL)	25
5.6	ROPE LOCKING CLAMP (OPTIONAL)	25
5.7	ALARM CONDITION WHEN USING CONNECTED MACHINES	25
5.7.1	STRINGING LENGTH ERROR	25
5.7.2	SWITCH ON THE MACHINE WITH CONTROL NOT IN NEUTRAL	25
5.7.3	EMERGENCY STOP	25
5.7.4	CAN-BUS DIS-CONNECTION BETWEEN THE MACHINES	26
5.7.5	ROPE-CLAMP POSITION	26
5.7.6	GEAR-BOX LOW-PULL POSITION	26
5.7.7	CONNECTION MACHINE SELECTOR	26
5.7.8	COMPONENT FAULT	26
<b>6.</b>	<b>SAFETY CONDITIONS</b>	<b>27</b>
6.1	SAFETY DEVICES	27
6.2	EMERGENCY STOP DEVICE	27
6.3	PERIODIC OPERATIONS	27
6.4	RESIDUAL RISKS	28
<b>7.</b>	<b>MAINTENANCE</b>	<b>29</b>
7.1	GENERAL PRESCRIPTIONS	29
7.2	LEVELS CONTROL	29
7.3	TYRES INFLATION PRESSURE	29
7.4	SUGGESTED LUBRICANTS	29
7.5	ENDOTHERMIC ENGINE MAINTENANCE	29
7.6	HYDRAULIC CIRCUIT MAINTENANCE	30
7.7	REDUCTION GEAR MAINTENANCE	30
7.8	RADIATOR'S MAINTENANCE	31
7.9	GREASING	31
7.10	OTHER PERIODIC OPERATIONS	31
7.11	SUMMARY TABLE FOR ORDINARY MAINTENANCE	31
<b>8.</b>	<b>HOW TO DISABLE THE MACHINE</b>	<b>32</b>
8.1	TRANSPORT	32
8.2	EXTENDED SERVICE STOP	32
8.3	STRIPPING	32
<b>9.</b>	<b>ENCLOSED DOCUMENTS</b>	<b>33</b>
9.1	TABLES	33
9.2	SYSTEMS	33
9.3	OTHER DOCUMENTS	33

## 2. GENERAL DATA AND PRESCRIPTIONS

### 2.1 MANUFACTURER

TESMEC S.p.A.

Via Zanica, 17/O  
24050 - GRASSOBBIO  
BG - ITALY  
tel. (+39)-035-4232911  
fax (+39)-035-4522445  
e-mail: info@tesmec.it

Via Pertegalli, 2  
24060 - ENDINE GAIANO  
BG - ITALY  
tel. (+39)-035-825024  
fax (+39)-035-826375  
e-mail: info@tesmec.it

### 2.2 COMMUNICATIONS WITH THE MANUFACTURER

For any information related to the machine (use, maintenance, spare parts) always state Model, Serial Number, Manufacturing Year and Order. These data can be found in the machine-identifying table.

### 2.3 TYPOLOGY AND USING FIELD

Puller-tensioner mod. AFS404 is suitable for stringing no. 1 or 2 bundled conductors with max. diameter of 34 mm and for recovering no. 1 or 2 ropes with 16 mm in diameter with a connector with max. diameter of 48.5 mm.

The machine is controlled by a hydraulic system that allows the machine to automatically work in PULLER or in TENSIONER mode.

The power transmission to the large groove bull-wheels is transmitted through a closed hydraulic circuit with a variable delivery pump and fixed displacement motor, with the possibility to change continuously the speed in both rotating directions.

A hydraulic vacuum brake stops automatically the two bull-wheels should the work be interrupted and a damage in the hydraulic circuit occur.

The machine is equipped with rapid couplers for connection to all types of reel winders and reel elevators made by Tesmec; the frame is complete with a rigid axle for towing at max. 30 km/h.

### 2.4 PERFORMANCES

#### PULLER PERFORMANCES

Max. pull	45 kN
Continuous pull	35 kN
Speed at continuous pull	3 km/h
Max. speed	5 km/h
Pull at max. speed	20 kN

#### TENSIONER PERFORMANCES

Max. tension	45 kN
Continuous tension	35 kN
Max. speed	5 km/h



**ATTENTION: the use of ropes with smaller diameter will reduce the pulling capacity of the machine, in accordance with the breaking load of the rope or of the conductor.**

Performances are referred to the machine without optional, at sea level and at 20°C.

## 2.5 TECHNICAL CHARACTERISTICS

Bull-wheels diameter:	1500 mm with interchangeable nylon sectors
Diesel engine:	63 kW – 2600 rpm – Cummins B3.3T
Electric system:	12 V
Transmission:	closed hydraulic circuit with hydraulic oil cooling
Safety brake:	negative and self-acting type
Dynamometer:	hydraulic with set-point and automatic control of maximum pull
Axle:	rigid type with mechanical parking brake for towing at a max. speed of 30-km/h
Dimensions:	length - 3125 mm width - 1960 mm height - 2570 mm
Mass:	2700 kg

## 2.6 ACOUSTIC EMISSION

Level of continuous sound pressure to the operator seat (UNI 9432) Lep = 85 dB(A)

## 2.7 GENERAL INFORMATION FOR THE MACHINE USE

- Only employed and qualified operators must use the machine. Qualified operators is intended to be the person who has received a qualified training from the using Company or, as alternative, from the manufacturer.
- Machine must be used **only** for the work it was designed for.
- Machine cannot be used with non-authorized personnel on the working site.
- For safety reasons, during transport machine comes without hydraulic oil and fuel. Characteristics and required quantities are listed in the present manual.
- For any doubt concerning use, functioning, maintenance or everything else, contact the After-sales Service of the manufacturer.

## 2.8 GENERAL PRESCRIPTIONS FOR THE OPERATOR CHARGED OF THE MACHINE USE

- Operator **has** to know safety directives for accident prevention in force in the machine using country, for a correct use of the same.
- The operator in charge with the installation and maintenance of the machine must use **suitable clothes** to the working site and to the situation where he finds himself; in particular he must avoid the use of very large clothes, chains, bracelets, rings or whatever can get entangled with moving parts.
- The operator has to use the necessary protecting devices (i.e. gloves, boots, helmet, etc.). **It is compulsory the use of personal protecting devices for hearing.**
- The operator must not carry out on his own initiative operations or interventions that are not up to him.
- The operator must carefully follow danger and/or prohibition prescriptions contained in the instruction manual or indicated on the machine.
- The working area of the operator has to be cleaned from possible oil or liquids wastes and free of materials or equipment that may be considered as an obstacle for the operator work.
- The operator **must absolutely avoid** the direct inhalation of the exhaust gas of the endothermic engine.

## 2.9 GENERAL PRESCRIPTIONS FOR THE OPERATOR CHARGED OF THE MACHINE MAINTENANCE

- a. **It is absolutely forbidden** to carry out any work of maintenance, adjustment or setting on units while stringing (except for the operations indicated in the present manual).
- b. Before carrying out any maintenance operations, **stop** the energy feeding (except for the cases indicated in the present manual) and wait till the cooling of the elements subjected to heating.
- c. All the maintenance operations of the machine must be carried out with machine on a level surface and not under load.
- d. Authorised and trained personnel must do all the maintenance operations, ordinary and not ordinary. Trained personnel are intended to be the person who has received a qualified training from the using Company or, as alternative, from the manufacturer.
- e. The operator in charge with the machine maintenance must use suitable clothes to the working site and to the situation where he finds himself; in particular he must avoid the use of very large clothes, chains, bracelets, rings or whatever can get entangled with moving parts.
- f. The operator has to use the necessary protecting devices (i.e. gloves, boots, helmet, etc.).
- g. All the maintenance operations, ordinary and not ordinary, must be effectuated respecting the prescriptions included in the present manual or following technical indications written by the manufacturer. The non-respect of the prescribed restrains relieves the manufacturer from any responsibility causing also the loss of warranty.

## 2.10 KNOWLEDGE AND CARE OF THE INSTRUCTION MANUAL

- a. The information contained in the instruction manual applies to all the operators charged with the use and/or the maintenance of the machine.
- b. The instruction manual **is not** a training manual.
- c. Before using the machine the chief of the job site and the operator **must** read the instruction manual.
- d. The chief of the job site **is obliged** to inform all the operators about the instructions contained in the manual.
- e. The user **must** carefully follow the instructions listed in the present manual.
- f. Before using the machine, the operator **must** be able to use it and **has** to exactly know the positions and the operations of all the controls.
- g. The chief of the job site must verify that the instructions contained in the manual are applied.
- h. The instruction manual must be kept, in order to be consulted, for all the life of the machine and also when it is given to another user.
- i. The instruction manual must be kept in a sheltered and dry place.



**ATTENTION: present manual belongs exclusively to the manufacturer.  
The reproduction, event partial, of the text is forbidden.**

## 2.11 CONDITION OF USE

- a. Temperature: from -10°C to +40°C.
- b. Relevant moisture: from 30% to 90% ± 5%.
- c. Weather conditions: any (in line with working conditions).
- d. Natural and/or artificial lighting of the working site.



**NOTE: the machine using and stocking is allowed till -20°C with preheating kit.**

## 2.12 TEMPERATURE LIMITS FOR HYDRAULIC OIL

When using the machine, always remember to respect the following temperature limits that can be reached with hydraulic oil as function of the working condition.

TEMPERATURE LIMITS FOR HYDRAULIC OIL (°C)				
Working condition	Hydraulic oil viscosity			
	VG 22	VG 32	VG 46	VG 68
Minimum temperature running in neutral position	-21	-14	-7	-1
Minimum temperature running in full load	8	16	24	32
Maximum temperature running in full load	48	57	67	76
Maximum temperature running in neutral position	63	73	83	93

For additional information concerning the hydraulic oil, see chapter "Maintenance" and the attached comparative table of the oils used on the machine.

## 2.13 USE NOT ALLOWED

The machine **must not be used**:

- a. for lifting persons and/or goods
- b. in grounds on which the machine cannot be positioned and anchored in a proper way
- c. in areas with brushwood or other materials presence that can be easily set on fire
- d. in closed/unventilated sites or, however, not sufficiently airy (tunnel or similar)
- e. in sites with presence of gas that can be easily set on fire or explosives
- f. in sites with presence of explosive materials
- g. on aircraft, crafts, floating platforms and similar
- h. for structure demolition, shafts felling or similar
- i. for pulling flexible elements that can be highly lengthening, which allow elastic power accumulation
- j. with ropes or joints having a bigger diameter than the one specified in present manual
- k. when engine is off and adherence units are moving
- l. with inhibited and broken safety devices installed on the machine
- m. when winding on the bull-wheels ropes and/or conductors having a smaller diameter as a succession of ropes and/or conductors having a bigger diameter
- n. for handling trucks or other moving equipment.



**PROHIBITION: is not allowed to install on board radio equipments. These could create electronic equipment malfunctions, putting the personnel at serious risk.**

## **2.14 RESPONSIBILITY**

The use of the machine for scopes different from those foreseen on paragraph 2.3 (Typology and using field), even if not well described in this manual, has to be considered extremely **dangerous** and then **forbidden**.

**The non-respect of the prescribed restrains causes a situation of improper use for technical and persons safety purposes and relieve the manufacturer from any responsibility, civil or penal, in case of accidents to persons or damages to things, causing the loss of warranty.**

The manufacturer responsibility declines even when one of the following situations happens:

- a. for the consequences caused by tampering and/or modifications carried out without the manufacturer's written acceptance (in this case the operator becomes the manufacturer with relevant obligations and responsibilities, both civil and penal)
- b. for the use of not original spare parts
- c. or bad maintenance
- d. for the use with disconnected safety devices
- e. for the connection to machine and/or plans not produced and not directly authorised by the manufacturer in a written acceptance.

## **2.15 APPLIED NORMS**

Machine is manufactured in conformity with the following norm:

**2006/42/CE** Norm of the European Parliament and Council, referring to the laws of the machines member States.

**2004/108/CE** Norm of the European Council, referring to the laws of the electromagnetic compatibility member States.

### **3. TRANSPORT AND POSITIONING INSTRUCTIONS**

#### **3.1 MACHINE LIFTING**

For the machine lifting use only devices as overhead travelling cranes or lift trucks, with a capacity equal to the mass to be lifted.

The instruments used for the machine lifting (ropes, cables, hooks, etc.) have to be exactly dimensioned as compared to the mass to be lifted and have to be connected to the proper elements foreseen on the machine (table 1, pos. 2).

During machine lifting operations, the presence of persons on the machine is strictly forbidden.



**DANGER:** the non-respect of the above mentioned conditions may cause dangerous situations as well as damages to the machine with the consequent decline of any warranty condition.

#### **3.2 TRANSPORT TYPOLOGIES AND PACKAGE**

##### Transport by land by truck

The machine comes without all the liquids that can be set on fire and protected in the most exposed and delicate parts by means of cardboard and/or plywood and/or polyethylene extensible film.

To fix the machine on the platform of the transporting unit, use nailed wedges and/or metal brackets and/or tie rods.

##### Transport by sea in wooden cases or container

The machine comes without all the liquids that can be set on fire; metal parts are protected with waterproof wax.

To fix the machine on the package, use nailed wedges and/or metal brackets and/or tie rods.

At the inside, the wooden case foreseen a protection with tarpaper.

Materials usually used for the package are:

- ⇒ wooden
- ⇒ nails and/or steel screws
- ⇒ cardboard and/or paper
- ⇒ polyethylene extensible film
- ⇒ adhesive tape.

#### **3.3 UNPACKING**

When receiving the machine verify the integrity of the package; advise immediately the manufacturer and the person in charge of the transport (even with photos) when possible damages due to transport or tampering with removal, even partial, of the content happen.

Verify if the supplied material corresponds to the ordered one; immediately advise the manufacturer if there are some discrepancies.

In case of transportation on wooden case, take away, in sequence, the upper cover and lateral panels, before removing the machine.

During unpacking operations, avoid any shock to the structure or to the machine units, in order to avoid any damage to the machine itself.



**ATTENTION:** the elimination of packaging materials must be effectuated in conformity with the norms in force in the relevant country.

### 3.4 ASSEMBLING OPERATIONS

Mount the tyres in the suitable holes.

### 3.5 TRANSPORT ON TRAILER

Machine is not suitable for road towing.

Possible displacements on trailer in the working site must be carried out by a connection to the towing unit by means of the towing eye on the drawbar (table 1, pos. 6) and in the respect of the speed limits of the axle. The used towing unit must be homologated for towing trailers with mass and dimensions as per the described machine.

Before transporting operation, lift the rear stabiliser (table 1, pos. 11) and the front plough (table 1, pos. 5) acting on the lever (table 3, pos. 29) (NOTE: during this operation the diesel engine has to be always started-up).

Check the inflation pressure of tyres (5 bars).

During trailer machine transport operations is nobody must stay in the machine itself.



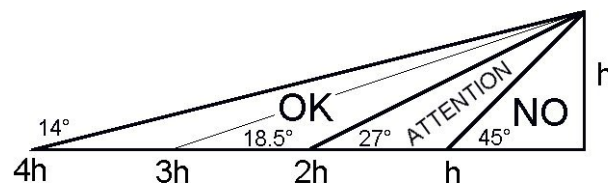
**ATTENTION:** dangerous situations during towing if the tyres inflation pressure and the speed limit are not respected may happen.

When transporting on truck or trailer, verify if the machine has been fixed on the platform with nailed wedges and/or metal brackets and/or tie rods.

### 3.6 POSITIONING AND ANCHORING

Positioning and anchoring of the machine have to be carried out only by trained personnel, verifying if the ground grants the foreseen stability, support and anchoring.

The machine has to be placed in a distance from the first pylon or trestle for the rope passage (or conductor) included between 2 and 4 times the height  $h$  of the pylon itself (see diagram here below).



It is possible to use the machine at a distance from the pole included between 1 and 2 times the height of the pole itself. In this case, the anchorage described thereafter must be over dimensioned of 125% compared to the reported data and some moorings must be provided on the front side of the machine.



**PROHIBITION:** when the distance between the machine and the pole is lower than the height of the pole itself, the machine use is not possible.

Machine anchoring sequence is the following:

- a. machine must be aligned as much as possible with the pull direction.
- b. position the rear stabiliser (table 1, pos. 10) and then load properly the plough (table 1, pos. 5) operating on the lever (table 3, pos. 29) (NOTE: during this operation the diesel engine has to be always started-up).
- c. anchor the machine to the ground by means of 2 stakes with min. granted load equal to 130% of the machine max. pull, connecting the foreseen connections (table 2, pos. 3) with the anchoring stakes and respecting the described scheme and angles (table 2).
- d. recover the clearance on the anchoring stakes without tensioning them.
- e. test the machine pull (see use instructions on the following chapter) to allow the machine to freely align as regards as the pull itself.
- f. tension the anchoring stakes in a uniform way.
- g. block the machine brakes acting on the special hand-wheel (table 1, pos. 9).



**ATTENTION:** the non-respect of the foreseen anchoring operations may cause dangerous situations during machine use.

Around the machine must be a free space of at least 2-m to make easier the operations of use, adjustment, maintenance, etc.


Be sure that around the radiator (endothermic engine, hydraulic oil) cooling air can freely circulate. Otherwise overheating situations with damage for the installed components may happen.



**DANGER:** machine has not a proper grounding device; for the system machine-rope-conductor in the job site must foreseen a grounding device on the towing rope or on the conductors.


## 4. INSTRUCTION FOR USE

### 4.1 PRESCRIPTIONS FOR THE OPERATOR

-  **PROHIBITION:** it is forbidden to walk or stop in front or backward the machine and/or under the towing rope due to a constant residual risk of crushing in case of a possible giving in of the rope or of the anchoring.

Daily, before starting the work, check:

- if the protection and safety devices are activated and functioning
- if the connections with power unit are in good conditions
- if the machine liquids levels are in conformity with the indications in maintenance chapter
- if the anchoring conditions are in conformity with the indications of present manual.


-  **NOTE:** when using the machine at room temperature between  $-10^{\circ}\text{C}$  and  $-20^{\circ}\text{C}$  it is necessary to carry out the preheating sequence as indicated at paragraph 4.10 and 4.11.

### 4.2 CONTROLS


Position and meaning of the elements on the control board are described on table 3 enclosed.

### 4.3 PRELIMINARY OPERATIONS


- Load the conductors or the cables on the bull-wheels as shown on tables 2 and 4 positioning the entering guide-rope rollers (table 2 and 4) in the proper position.

-  **ATTENTION:** do not use excessively lubricated or greased ropes because possible adherence problems on the bull-wheels with a consequent sliding of the ropes themselves may arise.

- Lubricate the gears before each starting of the machine using the proper greasers (table 2, pos. 2).
- Position the lever of mechanical transmission (table 2, pos. 9) into the proper ratio in accordance with the job to do:
  - ⇒ high pull (tension higher than 7kN) (table 2, pos. 9C)
  - ⇒ low pull (tension lower than 7kN) (table 2, pos. 9B)

-  **NOTE:** the stringing speed can be read on the manometer scale (table 3, pos. 1) relevant to the selected reduction ratio.

-  **ATTENTION:** this operation must be made only with stopped machine and without applied loads.

-  **PROHIBITION:** when you position the mechanical transmission control lever on the low pull (table 2, pos. 9B) on the panel switch on the red light (table 3, pos. 23), which advise that the machine cannot absolutely be used as puller but only as tensioner.

-  **DANGER:** please pay attention to the risk to be squeezed during the operations above described.

#### 4.4 MACHINE SET-UP

Before the use, the machine must be set in stand-alone using mode, operating on the control panel (table 3).

- a. insert and turn the ignition key (table 3, pos. 3) in "1" position
- b. wait up to the multifunction display switch on (table 3, pos. 17)
- c. on the electronic multifunction display press the (\*) key
- d. on the screen page "MACHINE ID:" set the number "1" by using the up (▲) or down (▼) key  
press the return key (↵) to save the settings



**NOTE: in case of stand-alone using mode the ID of the machine must always be set at 1**

When the machine is used in stand-alone configuration the two plug connectors must be closed with the related caps




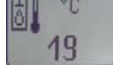


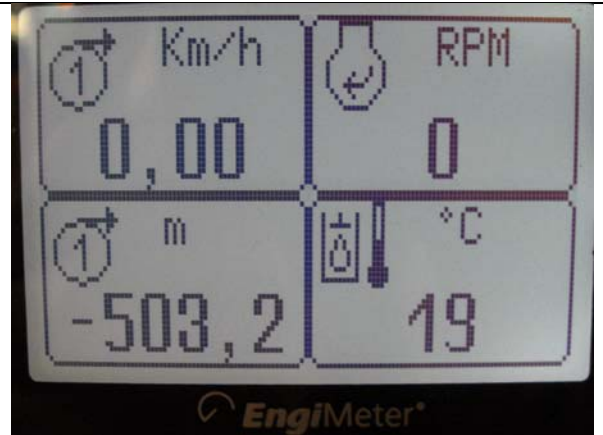
#### 4.5 ELECTRONIC MULTIFUNCTION DEVICE PAGES

The electronic multifunction display shows 4 working pages:

##### 1. METER COUNTER & SPEED PAGE




This page shows the speed and the meter counter for each independent circuit

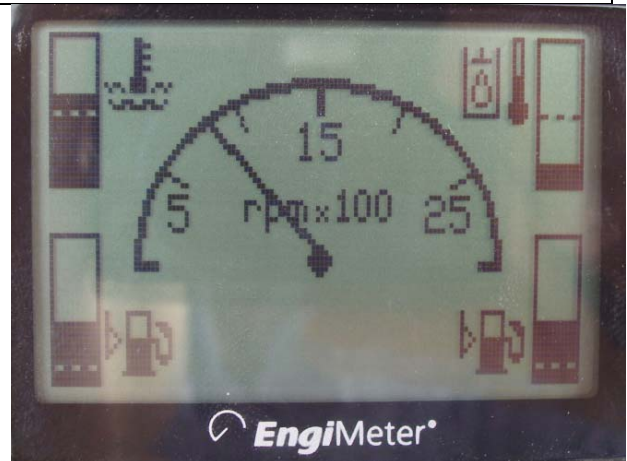
	0,00	speed of capstan nr.1
	-503,2	meter counter of capstan nr.1
	0	RPM diesel engine
	19	hydraulic oil temperature



##### 2. RPM & DIESEL ENGINE PAGE


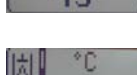
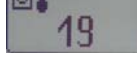
This page shows the rpm of the diesel engine in the center and 4 percentage check icons on the edges:

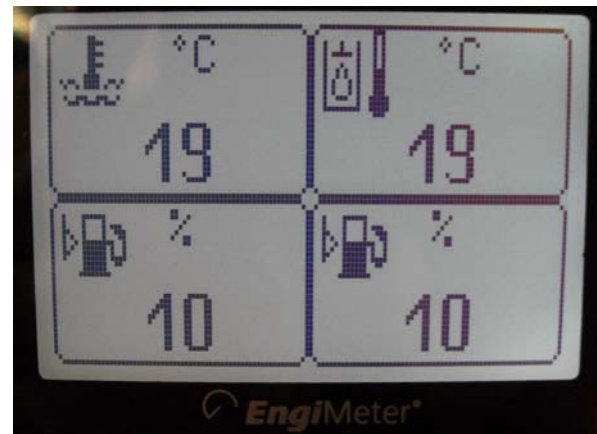
	diesel engine water cooling temperature
	hydraulic oil temperature
	diesel engine fuel level



##### 3. DIESEL ENGINE DATA PAGE

This page shows 4 percentage check icons of diesel engine data:

	19	diesel engine water cooling temperature
	19	hydraulic oil temperature
	10	diesel engine fuel level



#### 4. HOUR COUNTER PAGE

This page shows the working hour of the diesel engine in the center and 4 percentage check icons on the edges:



diesel engine water cooling temperature



hydraulic oil temperature



diesel engine fuel level



Switch from one page to the other one by using the up (▲) or down (▼) key

#### 4.6 STARTING OF THE MACHINE

- a. Operate from the principal control panel (table 3).
- b. Position to centre the control lever of the variable delivery pump (table 3, pos. 4).
- c. Turn of one point the starting key (table 3, pos. 14).
- d. Push and turn up to starting the starting key (table 3, pos. 14) and simultaneously keep the lever (table 3, pos. 13) lowered.  
The lever (table 3, pos. 13) must be lowered for a few seconds after the engine start-up.
- e. Regulate the rpm with the accelerator (table 3, pos. 12).
- f. Verify that the pressure indicate on the feeding manometer (table 3, pos. 7) is more than 20 bars with minimum rpm; on the contrary stop the machine.



**ATTENTION: when starting a cold machine, after heating the hydraulic oil as previously described, begin stringing operations limiting the maximum working performances for at least the first 15 minutes, that means to keep at half accelerator the Diesel rpm and don't exceed the 30% of the maximum stringing speed.**

#### 4.7 PULL CONTROL

The machine is equipped with two pull control devices for the control of the max. pull value on the line:

1. PULL LIMITING DEVICE that stops the machine when reaching the max. pull
2. PULL PROGRAMMING DEVICE that stops only the bull-wheels rotation keeping the diesel engine turned-on when reaching the max. pull.

##### 4.7.1 PULL LIMITING DEVICE SETTING

- Completely turn right the knob (table 3, pos. 6).
- With the suitable pawl, connected to the dynamometer (table 3, pos. 1), move the red arrow in correspondance of the max. pulling value that has not to be exceeded.  
When the pre-set pull value is reached, the machine stops automatically and the diesel engine turns off while the negative brakes automatically insert with the consequent stop of the bull-wheels rotation. When the pull value is exceeded the warning light (table 3, pos. 20) on the control panel turns on.





**DANGER: when using a machine as tensioner, position the pull limiting device (table 3, pos. 1) on the maximum scale, to avoid dangerous stopping. This operation is absolutely indispensable when the machine "tensioner" works with a puller without pull limiting device.**

#### 4.7.2 PULL PROGRAMMING DEVICE SETTING



**ATTENTION: THE OPERATIONS TO SET THE PULL MUST BE CARRIED OUT WITH STARTED DIESEL ENGINE BUT WHEN THE MACHINE IS TURNED OFF.**


- Start the diesel engine and set the engine at about 1600 rpm.
- Move the selector (table 3, pos. 5) on position  (rightwards).
- Gently move towards  (downwards) the lever (table 3, pos. 4).
- Turn the knob (table 3, pos. 6) till on the manometer ring nut (table 3, pos. 1) can be read the pull value that must not be exceeded.



**ATTENTION: the red arrow of the pull limiting device (par. 4.7.1) has to be positioned at a higher value than the one pre-set with the PULL PROGRAMMING DEVICE to avoid the machine stop.**




**DANGER: when using a machine as tensioner, position the pull limiting device (table 3, pos. 1) on the maximum scale, to avoid dangerous stopping. This operation is absolutely indispensable when the machine “tensioner” works with a puller without pull limiting device.**

- Gently move the lever (table 3, pos. 4) to central position (neutral position).
- Re-place the selector (table 3, pos. 5) on position  (leftwards).  
Once reached the set pull the bull-wheels automatically stop without the diesel engine turning off with the consequent machine stop. The bull-wheels will remain stopped till when the cause which tried to raise the pull over the imposed value is removed (line obstacles, increase of friction on the pulleys, braking mistakes, etc.).



**ATTENTION: after finishing the above mentioned operations and beginning stringing operations, it is important not to touch the knob (table 3, pos. 6). In fact, should the knob be rotated while the machine is stringing, this operation cancels the previous carried out calibration and the systems set on the new values congruent with new position of the knob. Then, avoid this operation, using it only in emergency situations.**






**ATTENTION: before starting the work, check if the selector (table 3, pos. 5) is on position . It is forbidden to move the selector (table 3, pos. 5) during working operations because dangerous situations because the machine immediately stops may happen.**



**ATTENTION: the dynamometer is calibrated with 3 scales: puller, tensioner and fine braking. Read the desired values in function of the operations to be carried out (pulling or tensioning).**

#### 4.8 CONNECTION MACHINE-HYDRAULIC HEAD OF THE REEL ELEVATOR OR REEL WINDER


Each hydraulic head (or each reel-winder) has a connecting kit consisting of two pipes. Each of these pipes has to be connected at the proper rapid connection (table 5, pos. 1-3 or 2-4) taking care to connect them properly (otherwise the installation will not work).


-  **ATTENTION:** it is important that, before connecting the rapid connections, the operator has checked their cleanliness as the introduction of dirt into the hydraulic circuit can create very serious damages.
-  **ATTENTION:** the rapid connections must be connected before to put in pressure the circuit.
-  **ATTENTION:** the cocks (table 5, pos. 5 e 6) must be opened when connecting the hydraulic heads (or reel winders).

#### 4.9 PULLING OPERATIONS

-  **ATTENTION:** before carrying out any operation it is necessary to verify if the selectors (table 3, pos. 5 and 27 – optional) are turned towards leftwards  .

- a. Adjust the rpm of the diesel engine using the accelerator (table 3, pos. 12): puller – 2600-rpm max., tensioner – 1800/2000 rpm. The number of rpm can be read on the instrument on the panel (table 3, pos. 17).
- b. Adjust the feeding pressure of the hydraulic heads connected to the machine by the valve (table 3, pos. 10) and read the correspondent value on the manometer (table 3, pos. 11).  
When using the machine as puller, the pressure of the hydraulic heads will be from 60 bars (reels with few turns) till a max. value of 120-130 bars (full reel).  
Using the machine as tensioner, the pressure of the hydraulic heads can be set at 60-70 bars.


-  **NOTE:** the adjusting valve (table 3, pos. 10) regulates the pressure of the two circuits of the reel elevators/reel winders, at the same time.

-  **ATTENTION:** it is important that this value is regulated at the minimum necessary value in function of the operations that we must carried out (recovery or stringing).  
In particular, during the final regulation of the bull-wheels, it is necessary to raise the pressure when we recover and lower it when we string: on the contrary, due to the mechanical and hydraulic efficiency, with the same set pressure we will have very different pulls back.

- c. Gently move the control lever of the pump (table 3, pos. 4) towards downwards  .

Now the machine is ready to work: if the tension is higher than the set working value, the machine operates as tensioner. If the tension is lower than the set working value, the machine operates as puller. The machine is completely automatic, for this reason when setting a pulling value, the machine works as puller or as tensioner following the motions of the opposite machine.

-  **ATTENTION:** the red arrow of the dynamometer (table 3, pos. 1) has to be positioned at a value higher than the one set with the knob (table 3, pos. 6).

-  **ATTENTION:** after starting stringing operations, it is important not to turn the knob (table 3, pos. 6). In fact, should the knob be rotated while the machine is stringing, this operation cancels the previous carried out calibration and the systems set on the new values congruent with new position of the knob.

- d. To stop the bull-wheels rotation, move the lever towards centre position (table 3, pos. 4).



**ATTENTION: do not quickly move the lever (table 3, pos. 4) towards centre position because a fast connection of the negative brakes that might produce dangerous damages to the disks mounted inside the brakes may happen.**

During stringing operations, the strung meters can be read on the relevant indicator. The indicator can be set to zero by pressing the push-button "RESET".

During functioning operations, verify that:

- the hydraulic oil temperature, shown on the thermometer (table 3, pos. 16), doesn't exceed 80°C. This is the maximum acceptable value for the hydraulic components in case the oils suggested by Tesmec are used. If other kinds of oils are used, the maximum acceptable working temperature depends on their characteristics in relation also to the viscosity limits imposed by the hydraulic pumps and motors.
- the warning lights of the electric clogging indicators mounted on the control board (table 3, pos. 24 and 25) don't switch on when the hydraulic oil reaches the working temperature. However, it may happen that the lights indicate clogging even if it doesn't occur (especially at very low outside temperatures). In this case, see point e) paragraph 4.4 and wait for the lights to turn off before making the bull-wheels run.


#### 4.10 RELEASING THE ROPE

The rope or the conductor can be released, not under load, moving the lever (table 3, pos. 4) upwards




#### 4.11 COMPRESSOR CONNECTION (OPTIONAL)

The machine has been studied to be connected to a Tesmec compressor.

- Connect the rapid couplers (table 6, pos. 5 and 6).
- Start the machine, turn the selector (table 3, pos. 27) towards right position  and close the valve (table 3, pos. 8).
- Lower the lever (table 6, pos. 4) in "A" position.
- Adjust the functioning pressure of the compressor using the valve (table 6, pos. 1). The pressure can be read on the manometer (table 6, pos. 2).

Once ended the compressing operations, to use the machine act as follows:

- turn the valve (table 6, pos. 1) and lower the pressure in the compressor.
- lift the lever (table 6, pos. 4) in "B" position.
- open the valve (table 3, pos. 8).
- turn the selector (table 3, pos. 27) towards left position .
- remove the rapid couplers (table 6, pos. 5 e 6).



**ATTENTION: the connection of the rapid couplers has to be effectuated with the lever (table 6, pos. 4) in "B" position to discharge the pressure in the hydraulic circuit. If there is residual pressure in the hydraulic circuit, it is not possible to connect and disconnect the rapid couplers.**

#### 4.12 PREHEATING KIT (OPTIONAL)

The machine is equipped with a preheating kit (see table 8) to be used when room temperatures are included between -10°C and -20°C.

This kit is composed by a gas-oil burner and by an heating circuit that uses the cooling liquid of the diesel engine: the consumption heated by the preheating kit are the diesel engine block, the hydraulic oil tank, the diesel engine gas-oil tank and the delivery of the gas-oil to the diesel engine.

The gas-oil for the preheating kit burner has to have the following technical specifications (DIN 51601):

- 70% winter gas-oil
- 30% petroleum or kerosene

In case of temperatures higher than -10°C, or whatever when the preheating system is not used, set the two cocks for the preheating circuit cut out (table 8, pos. 3-5) on SUMMER position, while when the preheating system is used, set the cocks on WINTER position.



**ATTENTION: before starting the preheating system, check if the two cocks (table 8, pos. 3-5) are on WINTER position.**

**On the contrary, the preheating system doesn't work and may be damaged.**

To start the preheating system, push the push-button (table 8, pos. 11) on the control panel (table 8, pos. 1): the system starts automatically.



**ATTENTION: when the diesel engine is working, the preheating kit has to be switched off.**



**ATTENTION: for using the heater, the pump blow-by selector (table 8, pos. 14) has to be on automatic position (leftwards).**

Once stopped the preheating system and with functioning diesel engine, if the operator wishes to heat the gas-oil and hydraulic oil tanks, it is possible to activate the liquid blow-by pump acting on the selector (table 8, pos. 14) – manual position (rightwards).

Please consider that the heater liquid reaches the service temperatures in about 20 functioning minutes, while after 30 functioning minutes of the heater, the temperature of the hydraulic oil in the relevant tank increases of about 10°.

#### 4.13 PREHEATING CONTROL PANEL PROGRAMMING (OPTIONAL)

##### 4.13.1 GENERAL (OPTIONAL)

The standard digital timer/combination timer enables to pre-set the start of the heater operation up to 7 days in advance. It is possible to program 3 different starting times, only one of which can be activated. The standard digital timer features a wakeup alarm function.



When the ignition switched on, the timer displays the current time and the day of the week.



When the heater is switched on, the display and the buttons are illuminated.

After the power supply has been connected, all symbols on the display will flash.

The current time and weekday must be set.

##### 4.13.2 OPERATION (OPTIONAL)

The timer can be operated so that all flashing symbols can be adjusted by means of the  and  buttons. If the buttons are not pressed within 5 seconds, the time displayed will be stored.

If the  and  buttons are pressed for more than 2 seconds, the fast time-setting mode is activated.

If the ignition is switched off while the heater is operating in the continuous mode, the remaining operating time of 15 minutes is displayed and the heater continues to operated for this period of time.




#### 4.13.3 SWITCHING THE HEATER ON (OPTIONAL)

Manually: by pressing the button  (continuous heating mode).  
Automatically: by programming the heater starting time.


#### 4.13.4 SWITCHING THE HEATER OFF (OPTIONAL)

Manually: by pressing the button .  
Automatically: after the programmed operating time has elapsed.  
With the heater running: by programming the remaining operating time.





#### 4.13.5 SETTING TIME/DAY OF THE WEEK (OPTIONAL)

Press the  button for more than 2 seconds – time of the day is flashing.  
Set the clock using the  and  buttons – day of the week is flashing – adjust the day of the week.



#### 4.13.6 VIEWING THE TIME (OPTIONAL)

With the ignition switched off: press the  button.




#### 4.13.7 PROGRAMMING HEATER STARTING TIME (OPTIONAL)

Press the  button – the memory location is flashing – using the  and  buttons set start of the heater operating time. Day of the week is flashing – set the day of the week.  
By repeatedly pressing the  button, memory locations 2 and 3 can be programmed or the time display mode can be reached.



#### 4.13.8 RECALLING/ERASING PRE-SET TIMES (OPTIONAL)

Repeatedly press the  button until the desired memory location is displayed.  
To erase the pre-set time, press the  button several times until the time of the day is displayed instead of the memory location.

#### 4.13.9 PROGRAMMING DURATION OF OPERATING TIME (OPTIONAL)





The heater must be switched off. Press the  button for 3 seconds – operating times is flashing – and set the desired operating time (10 to 120 minutes) using the  and  buttons.

#### 4.13.10 SETTING THE REMAINING OPERATING TIME (OPTIONAL)





Set the desired remaining operating time (1 to 120 minutes) using the  and  buttons.  
The remaining operating time refers to the time the heater still continues to remain in operation.  
It can only be changed while the heater is in operation and the ignition switched off.

#### 4.13.11 SETTING THE WAKEUP TIME (OPTIONAL)

A wakeup time can only be programmed on the standard digital timer.  
The wakeup time is not bound to a specific day of the week.

Repeatedly press the  button until the bell symbol  appears on the display.  
Set the desired wakeup time using the  and  buttons.  
The alarm clock turns off after 5 minutes or when one of the buttons is pressed.


#### 4.13.12 RECALLING/ERASING THE WAKEUP TIME (OPTIONAL)


Repeatedly press the  button until the bell symbol  appears on the display – read off wakeup time. To erase the wakeup time: press the  button until the bell symbol  is no longer visible on the display.

#### 4.14 ROPE LOCKING CLAMP (OPTIONAL)

The rope locking clamp allows blocking the rope end towards the reel winder and therefore the operations for removing the reel are speed up.

The rope locking clamp can be connected acting on the selector (table 3, pos. 30).

To engage the rope locking clamp, turn the selector (table 3, pos. 30) on  position (blocked).

When the machine is working the selector has to be turned on  position (free).

#### 4.15 POINTS TO REMEMBER

- a. The pressure of feeding circuit (table 3, pos. 7) must be more than 20 bars: otherwise, the stationary brakes could be damaged.
- b. Adjust the pull of reel elevators with hydraulic head (table 3, pos. 10) at minimum indispensable value: otherwise, the hydraulic oil could be heated and dangerous counter pulls may arise.
- c. In hot climates, during the stoppages, let running the Diesel engine with the radiator fan connected (table 3, pos. 8) at maximum speed.
- d. Before beginning the works, check the levels.
- e. Respect the temperature limits for the hydraulic oil as indicated at paragraph 2.12.
- f. Check the condition of the discs in the emergency brakes after any emergency intervention.
- g. Remember to use the values indicated on the scale “puller” for the recovery phases and those indicated on the scale “tensioner” for the stringing phases.
- h. When we use the machine as tensioner, position the pull limiting device – red arrow (table 3, pos. 1) on the minimum scale, to avoid dangerous stopping.  
This operation is absolutely indispensable when the tensioner machine work with a puller without automatic limiting pull device.
- i. The connecting operations of the mechanical reduction gear (table 2, pos. 9) must be made only with stopped machine and not under charge.

#### 4.16 END OF THE OPERATIONS

At the end of the operations, discharge the ropes-conductors tension using the control lever (table 3, pos. 4). Then stop the engine operating on the starting key.

## 5. INSTRUCTION FOR USE – CONNECTED MACHINES

### 5.1 GENERAL ASPECTS

This machines could be equipped with an electronic connection package as an optional device.

This device allow to use multiple machines connected between them, controlled and operated by a single operator for the main working parameters (basically speed, pull, diesel engine rpm).

Is possible to connect a maximum 12 machines between them, with the possibility to work with 12 independent ropes configurations.

Tesmec suggest to use this configuration device on machine working at the puller station, to allow to recover multiple ropes or conductors with the same speed.

The machines must be numbered with ID number (see next chapter) from 1 to the number of total connected machines starting from right to left, looking at the machines from the back (reel-winder position). The last machine, positioned on the right, is the master machine. See table 10 as example.

The machines must be connected through a special connecting cable; the un-used plugs on the first and on the last machine (right and left) must always be closed with the related caps. To grant the continuous connection of the machines, a special protection device must be provided for the connection cables, to avoid accidental disconnection of the communication between the machines.



It is necessary to provide a correct grounding of each machine, to avoid trouble at the electronic devices. For this reason each machine is equipped with a special grounding device that must be connected prior to switch on each machine.

The correct grounding configuration is realized with a grounding stakes (see table 9) to be placed on the ground in front at the machine, and a connecting ground cable, that must connect all the ground stakes between them.



Prior to operate the set-up of the machines, check that:

- The machines are connected through the special connecting cable
- The ground devices are installed and connected
- The gear-box configuration is HIGH-PULL in each machine (optional)

## 5.2 MACHINES SET-UP

Before the use the machine must be set in connected mode by assign to each machine the correct ID number, starting from left to right, as described in the previous chapter.

- a. insert and turn the ignition key (table 3, pos. 14) in "1" position
- b. wait up to the multifunction display switch on (table 3, pos. 17)
- c. on the electronic multifunction display press the (\*) key
- d. on the screen page "MACHINE ID:" set the correct number by using the up (▲) or down (▼) key
- e. press the return key (↵) to save the settings



**NOTE:** the ID of the machines must be set from 1 to the total number of connected machines starting from left to right (looking at the machines from the back – reel-winder position)

- e. set each machine in connection configuration, except the final one, by turning rightwards the selector (table 3, pos. 3).

### 5.3 CONNECTED MACHINES OPERATIONS

When using connected machines, the following controls effect on all machines when operated from the master machine:

- Speed control (joy-stick)
- Pull-adjusting control (potentiometer)
- Negative brake open – close selector
- Diesel engine accelerator
- Rope-clamp selector

When using connected machines, the following controls must be operated on each single machine:

- Reel-winder working pressure
- Reset of meter counter
- Pull limiting device in the dynamometers
- Main front plough position

### 5.4 PULL CONTROL SETTING

#### 5.4.1 PULL LIMITING DEVICE SETTING

With the suitable pawl, connected to the dynamometers (table 3, pos. 12), move the red arrow in correspondence of the max. pulling value that has not to be exceeded.

The pre-set value must be the same for all the machines connected, and must be set on each single machine.

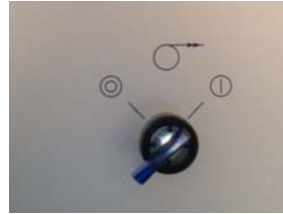
#### 5.4.2 PULL PROGRAMMING DEVICE SETTING

The setting must be operated at the circuit of the last connected machine and will effect on all the machines.

The operation sequence is the same described on the stand alone using mode chapter 4.7.2.

### 5.5 USING OF ELECTRONIC SPEED SYNCHRONIZER DEVICE (OPTIONAL)


The machine could be provided with an electronic speed synchronizer device as a optional package; to activate operate on the selector (table 3, pos. 9) (rightwards) on the master machine.




This device allow to have the same recovering speed of each connected machines.

### 5.6 ROPE LOCKING CLAMP (OPTIONAL)

When the machine are connected the proper selector on the master machine operate on all the clamps of the connected machines.

To engage the rope locking clamp, turn the proper selector on the master machine (table 3, pos.30) on  position (leftwards - blocked – no light) and keep it in position for a few second to allow the complete closing of the clamp.



To dis-engage the rope locking clamp, turn the proper selector on the master machine (table 3, pos.30) on  position (rightwards – free – green light) and keep it in position for a few second to allow the complete opening of the clamp.



### 5.7 ALARM CONDITION WHEN USING CONNECTED MACHINES

When using connected machines some situation generate alarm condition with switch on of the alarm light on the main control panel of the machine where the alarm is generated.

#### 5.7.1 STRINGING LENGTH ERROR

When the electronic speed synchronizer system is active, an eventual difference of stringing length on the independent ropes larger than a default value programmed (generally 6 m) generate an error and the stringing operations stops on all the connected machines.

To reset the alarm move the joy-stick to neutral on the master machine and dis-engaged the speed synchronized selector; check the cause of the alarm on the line (ex. Operation of the pull programming system and arrest of one rope line) before to re-start.

#### 5.7.2 SWITCH ON THE MACHINE WITH CONTROL NOT IN NEUTRAL

When the machine is switched on with joy-stick not in neutral position, an alarm is generated and the capstans don't move.

#### 5.7.3 EMERGENCY STOP

Pressing the emergency stop in one of the connected machines generate the stop of the engine of the single machine where the stop has been activated and the stop of the movement of all the remaining connected machines, where the diesel engine remain switched on.

To reset the alarm move the joy-stick to neutral on the master machine before to dis-engaged the emergency stop on the machine in emergency situation.

#### 5.7.4 CAN-BUS DIS-CONNECTION BETWEEN THE MACHINES

In case the connection cables between the machine may disconnect (ex. removing plugs, accidental cutting of one cable, ...), the stringing operations stops on all the connected machines.

To reset the alarm move the joy-stick to neutral on the master machine and check the cause of the fault.

#### 5.7.5 ROPE-CLAMP POSITION

In case one of the rope-clamp is not completely open (electrical switch pressed and green light switched on), none of the ropes can moves on all the connected machines.

#### 5.7.6 GEAR-BOX LOW-PULL POSITION

In case one of the gear-boxes is in a low-pull position, (electrical switch pressed and green light switched on), none of the ropes can moves on all the connected machines.

#### 5.7.7 CONNECTION MACHINE SELECTOR

In case one of the connection machine selector is changed to off (leftwards) while connected machine are running, all the machines will stop.

#### 5.7.8 COMPONENT FAULT

In case of fault in one of the joy-stick & potentiometers component, the system switches on default parameters with alarm indicator on control panel (L1 or L2).

In case of fault on pull adjusting solenoid valve the system only shows alarm indicator on control panel (L1 or L2).

## 6. SAFETY CONDITIONS

### 6.1 SAFETY DEVICES

Machine has been equipped with the following safety devices:

1. load-limiting device with automatic stop of the endothermic engine once the max. pre-set load value has been exceeded
2. mechanical negative safety brake for movement stop in case of lack of hydraulic pressure
3. timing case and protections on moving parts, where technologically possible.



**DANGER:** it is absolutely forbidden the use of the machine without protecting timing cases or with damaged/disconnected safety devices.



**ATTENTION:** after a serious emergency use of the negative safety brake, check the wear condition of the discs and the efficiency of the brake itself; if necessary, replace the brake discs before re-using the machine.

### 6.2 EMERGENCY STOP DEVICE

The machine is equipped with an emergency stop device (table 3, pos. 2) that directly acts on the Diesel engine.

The power generator locking causes the intervention of the vacuum brakes and, consequently, the complete machine stop.



**ATTENTION:** use the emergency stop device **ONLY** in danger situations for the operators' safety.



**NOTE:** for restoring the machine it is necessary to unlock the emergency device with a deliberate manoeuvre (turn for a quarter, in clockwise direction, the push-button).



The emergency stop device for stopping the machine while working must only be used in emergencies.

### 6.3 PERIODIC OPERATIONS

Daily, before starting the work, the operator **has** to verify the functionality of the machine safety devices.



**ATTENTION:** do not modify for any reason safety devices of the machine because the manufacturer declines any responsibility as consequence of the non-functioning of the same.

## 6.4 RESIDUAL RISKS

In the machine there are still the following residual risks:

- 1. Sudden break of the rope-conductor.** The break of the rope causes sudden movements of the machine and of the rope or conductor connected to the machine.  
To reduce to min. the risks the operator has to:
  - ⇒ check the rope and replace it as soon as appear some defects or wear signs
  - ⇒ respect the working positions indicated in the manual.
- 2. Sudden break of the anchoring stakes.** The sudden break of the anchoring stakes causes the machine instability and sudden movements of the same.  
To reduce to min. the risks the operator has to:
  - ⇒ periodically check the anchoring stakes and replace them as soon as appear some defects or wear signs
  - ⇒ follow the anchoring indications described in the present manual
  - ⇒ respect the working positions indicated in the manual.
- 3. Entangling or dragging of the accessible rotating units.** It is not technologically possible to foreseen covering in correspondence of some rotating units (i.e. winding of the rope or of the conductor on the bull-wheels or on the driving gears), due to an excessive restriction of the machine functionality and operative functions.  
To reduce to min. the risks the operator has to:
  - ⇒ avoid any possible contact with the machine rotating units except for the control devices
  - ⇒ respect the prescriptions indicated in the present manual concerning wearing and the necessary safety devices.
- 4. Limbs crushing during loading or removal of the reel and during rope-conductor loading.** These operations have a large risk margin due to the use of mechanical parts to be moved.  
To reduce to min. the risks the operator has to:
  - ⇒ know the directives for accident prevention and apply them.
- 5. Electrostatic discharges.** The machine has not a proper grounding device for this reason during stringing operation it is possible to have dangerous electrostatics discharges on ropes and conductors.  
To reduce to min. the risks the operator has to:
  - ⇒ know the directives for accident prevention and apply them
  - ⇒ check if the job site has a suitable grounding device for the machine-rope-conductors system.
- 6. Inhalation of the endothermic engine exhausting gas.** The machine discharge exhausting gas of the endothermic engine combustion.  
To reduce to min. the risks the operator has to:
  - ⇒ respect the working positions indicated in the manual
  - ⇒ respect the indications of attention and prohibition indicated in the present manual
  - ⇒ if necessary, use safety devices for the respiratory tracts.
- 7. Control lever that can be locked in working position.** For functional reasons and comfort in the use the control lever does not foresees the return to zero when released; anyway the machine is equipped with two security devices which prevent the creation of dangerous situations: electric limiting device of the pull on the dynamometer, which stops the power station when the stated value is reached, and load pre-setting device, which maintains the settled pull adjusting automatically the speed of the work.  
To reduce to the minimum the risks the operator must:
  - ⇒ put the electric limiting device of the pull on a value just superior of the regulating valves of the pull (see par. 4.5)
  - ⇒ plan the desired pull as described in the manual (see par. 4.5).

## 7. MAINTENANCE

### 7.1 GENERAL PRESCRIPTIONS



**ATTENTION:** possible repairs not carried out by the manufacturer and not allowed by a written authorisation relieve the manufacturer for any responsibility in case of accidents to persons or damages to things and/or to the machine, causing also the loss of warranty.

### 7.2 LEVELS CONTROL

For safety reasons, during the transport machine comes without hydraulic oil and fuel.  
Fill the levels as per the following table:

	<i>Quantity</i>
a. Hydraulic oil level (table 1, pos. 1)	180 l
b. Reduction gear oil level (table 2, pos. 13)	1.6 l
c. Parking brake oil level (table 2, pos. 10)	0.3 l
d. Engine oil level (see enclosed engine booklet)	
e. Fuel level (table 1, pos. 4)	95 l



**ATTENTION:** the non-respect of the correct levels causes serious damages to the installed components.



**DANGER:** do not ingest hydraulic liquids, fuels and cooling liquids because injurious to health and potentially lethal.

### 7.3 TYRES INFLATION PRESSURE

Tyres inflation pressure has to be 5 bars.



**ATTENTION:** the non-respect of tyres inflation pressure causes dangerous situations during transport operations.

### 7.4 SUGGESTED LUBRICANTS

The manufacturer tests the machine with the following oils and lubricants:

- a. hydraulic circuit and stationary brake: IP HYDRUS OIL 46 (ISO HM 46)
- b. mechanical reduction gear: IP MELLANA-220 (ISO CKC 220).

Possible different trademarks must be chosen based on the enclosed table "SUGGESTED LUBRICANTS". It is possible to use different trademarks but with same characteristics and ISO specifications.

When using oil with characteristics and ISO specifications different from the ones declared during test, completely empty out the hydraulic circuit.



**ATTENTION:** the use of lubricants not in conformity with the technical specifications indicated in the present manual seriously damages the machine components and, consequently, the warranty conditions are not valid.

### 7.5 ENDOTHERMIC ENGINE MAINTENANCE

For the specific maintenance of the engine, see the enclosed use and maintenance booklet.  
For filling the fuel, use the filling cap on the tank (table 1, pos. 4).



**DANGER:** to fill the fuel turn off the engine; before carrying out any operation let the engine be cooled.

## 7.6 HYDRAULIC CIRCUIT MAINTENANCE

- a. Change the hydraulic oil after 500 working hours and, then, every 1500 hours (or in any case every year).
- b. To discharge the exhaust hydraulic oil, use the suitable tap (table 1, pos. 13) on the bottom of the tank.



**DANGER:** let the hydraulic oil be completely cooled before removing it and always use the suitable safety wears (gloves, etc.).



**ATTENTION:** the discharge of the exhaust oils has to be effectuated in conformity with the laws in force in the relevant country.

- c. Fill the oil in the tank by means of the suitable filler (table 1, pos. 8).



**ATTENTION:** make maximum care when filling to make sure no foreign matter, which could cause irreparable damages to the circuit's components, enters along with the oil; if possible filter the oil with a 10 µm filter.

- d. Replace the filter cartridges (table 2, pos. 5 and 6 and 16 – optional) after 500 working hours and, then, every 1500 hours (or every year at least).
- e. Daily check the clogging of the oil filters by means of the suitable indicators (table 3, pos. 24 and 25) on the control panel. If necessary replace the cartridges taking care of the following filtering grade:
  - ⇒ intake filter (table 2, pos. 5): 10 µ (nominal values)
  - ⇒ intake filter (table 2, pos. 6): 90 µ (nominal values)
  - ⇒ intake filter (table 2, pos. 16): 25 µ (nominal values) (optional)

For further maintenance operations of installed hydraulic components (pumps and motors), refer to the enclosed documentation.

## 7.7 REDUCTION GEAR MAINTENANCE

- a. Change the oil of the reduction gear after 50 working hours and, then, every 500 hours (or every year at least).
- b. To discharge the exhaust oil of the reduction gear, use the suitable caps on the lower part of the casing of the same.



**DANGER:** let the hydraulic oil be completely cooled before removing it and always use the suitable safety wears (gloves, etc.).



**ATTENTION:** the discharge of the exhaust oils has to be effectuated in conformity with the laws in force in the relevant country.

- c. Fill the oil of the reduction gear by means of the suitable caps on the upper part of the casing of the same.



**ATTENTION:** make maximum care when filling to make sure no foreign matter, which could cause irreparable damages to the circuit's components, enters along with the oil.

For further maintenance operations of installed hydraulic components (pumps and motors), refer to the enclosed documentation.

## 7.8 RADIATOR'S MAINTENANCE

At least once a year, or more in case of use in dusty places, is foreseen a blowhole with compressed air of the radiant mass of the radiators.



**ATTENTION:** in order to make this operation the one in charge of maintenance, besides wearing all the protection devices already shown in this manual, must also wear a device for protecting respiratory organs.

## 7.9 GREASING

Grease 2-3 times per day the crown gear of the bull-wheels using the suitable greaser (table 2, pos. 2).

Weekly grease all the other parts subjected to rotation or translation and that not foreseen a forced lubrication or an automatic greasing.

Use IP ATHEZIA GR2 (ISO XBCEA 2) grease or equivalent of another trademark based on the enclosed "SUGGESTED LUBRICANTS" table.

## 7.10 OTHER PERIODIC OPERATIONS

When cleaning the machine, avoid direct jets of water or steam on the components of the electric system of the machine and on the control panel.

For the other periodic operations, refer to the summary table for the ordinary maintenance (see next paragraph).

## 7.11 SUMMARY TABLE FOR ORDINARY MAINTENANCE

In this card are listed main operation of periodic maintenance and relevant intervals.

Part	Object	Interval				
		Daily	50 h	250 h	500 h	1500 h
Diesel engine (***)	Engine oil	CL		ST		
	Oil filter			ST		
	Cooling liquid	CL				ST
	Air filter			VF		ST
	Fuel	CL				
	Fuel filter				ST	
Hydraulic circuit	Hydraulic oil	CL			ST1	ST(*)
	Filters	VF			ST1	ST(*)
Negative brake	Discs	(**)				
Reduction gear	Oil	CL	ST1		ST(*)	
Bull-wheels	Gears	GR				
Front plough	Rod		GR			
Axle	Tyres pressure		VF			
	Stationary brake		GR			

Legend:

**CL** Check the level (and possible filling up)

**GR** Grease

**ST** Replace

**ST1** Replace (only for the first intervene)

**VF** Check

(\*) Or in any case every year

(\*\*) Check the discs wear condition after an emergency stop

(\*\*\*) For further information see the engine booklet

## **8. HOW TO DISABLE THE MACHINE**

### **8.1 TRANSPORT**

Before transporting the machine, empty any liquid that can be set on fire contained in the machine (oils and fuels).

Transport must be effectuated as per the specifications described in chapter 3 (Transport and positioning instructions).

### **8.2 EXTENDED SERVICE STOP**

When foreseeing an extended service stop (two months at least) protect the external parts with waterproof wax and empty the fuel tank.

During service stop, start the machine at least once every two months and let the machine idle for one hour at least, so that the oil enters in the hydraulic system and to prevent the gaskets drying.

We recommend stocking the machine under a roof; do not cover the machine with pieces of cloth and/or plastic materials that cause an excessive increase of the temperature and humidity.

If the machine does not work for a year or more, before re-starting the machine it is necessary to replace the hydraulic oil and filters of the hydraulic circuit.

### **8.3 STRIPPING**

Machine stripping has to be carried out by the manufacturer or by a specialised factory.

All the stripping operations have to be effectuated in conformity with the norms in force for accident prevention.

Waste materials have to be divided for typology (i.e. iron scrap, aluminium, plastic, rub, etc.) and disposed of by means of authorised structures in conformity with the laws in force.

Exhausted oils and polluting substances have to be disposed of by means of authorised structures in conformity with the laws in force.

## **9. ENCLOSED DOCUMENTS**

### **9.1 TABLES**

TABLE 1.5	General assembly – Lateral view
TABLE 2.5	General assembly – Upper view
TABLE 3.6	Control panel
TABLE 4.3	Machine set to pull 2 conductors
TABLE 5.1	Hydraulic heads connection
TABLE 6.2	Compressor connection (optional)
TABLE 7.1	Radio control and pull recording unit connection (optional)
TABLE 8.1	Preheating kit (optional)
TABLE 9.1	Machine connection (optional)
Comparative table of suggested oils and greases	

### **9.2 SYSTEMS**

A10-00003	Frame assembly drawing
A11-00003	Bull-wheels assembly drawing
A12-00003	Reduction assembly drawing
A13-00003	Coverings assembly drawing
A14-00047	Feeding system assembly drawing
A15-00018	Control panel assembly drawing
A17-00003	Nylon roller assembly drawing
S01-00010	Electric system
S02-00024	Functional hydraulic system

### **9.3 OTHER DOCUMENTS**

Manual for engine use and maintenance mod. Cummins B3.3T



---

---

PULLER-TENSIONER MOD. AFS404

*TABLES*

---

---

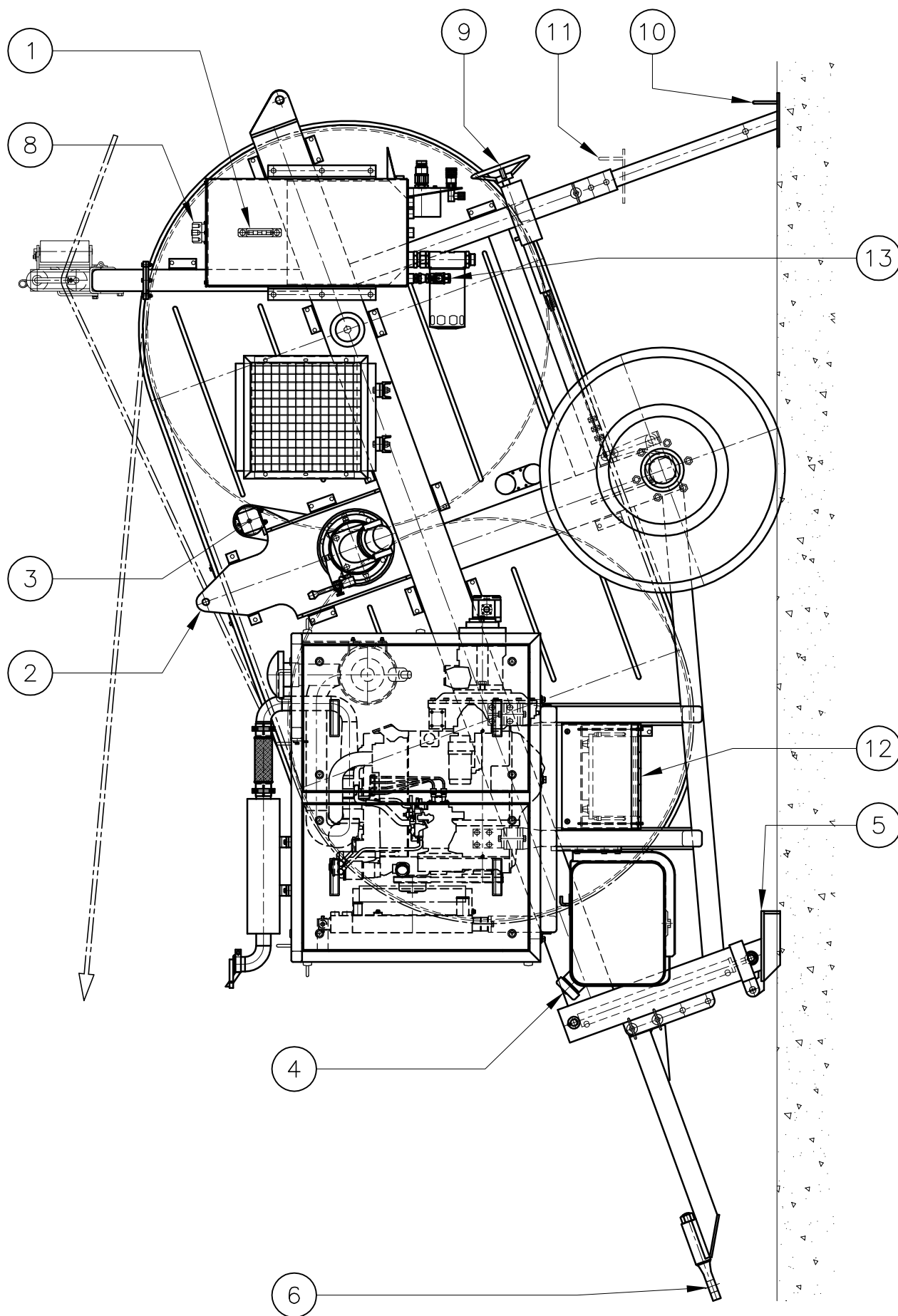


- 24050 Grassobbio (Bg) via Zanica, 17/O  
Tel. 0039 / 035 / 4232911  
Telefax 0039 / 035 / 4522445  
E-mail: info@tesmec.it

- 24060 Endine Gaiano (Bg) via Pertegalli  
Tel. 0039 / 035 / 825024  
Telefax 0039 / 035 / 826375  
E-mail: info@tesmec.it

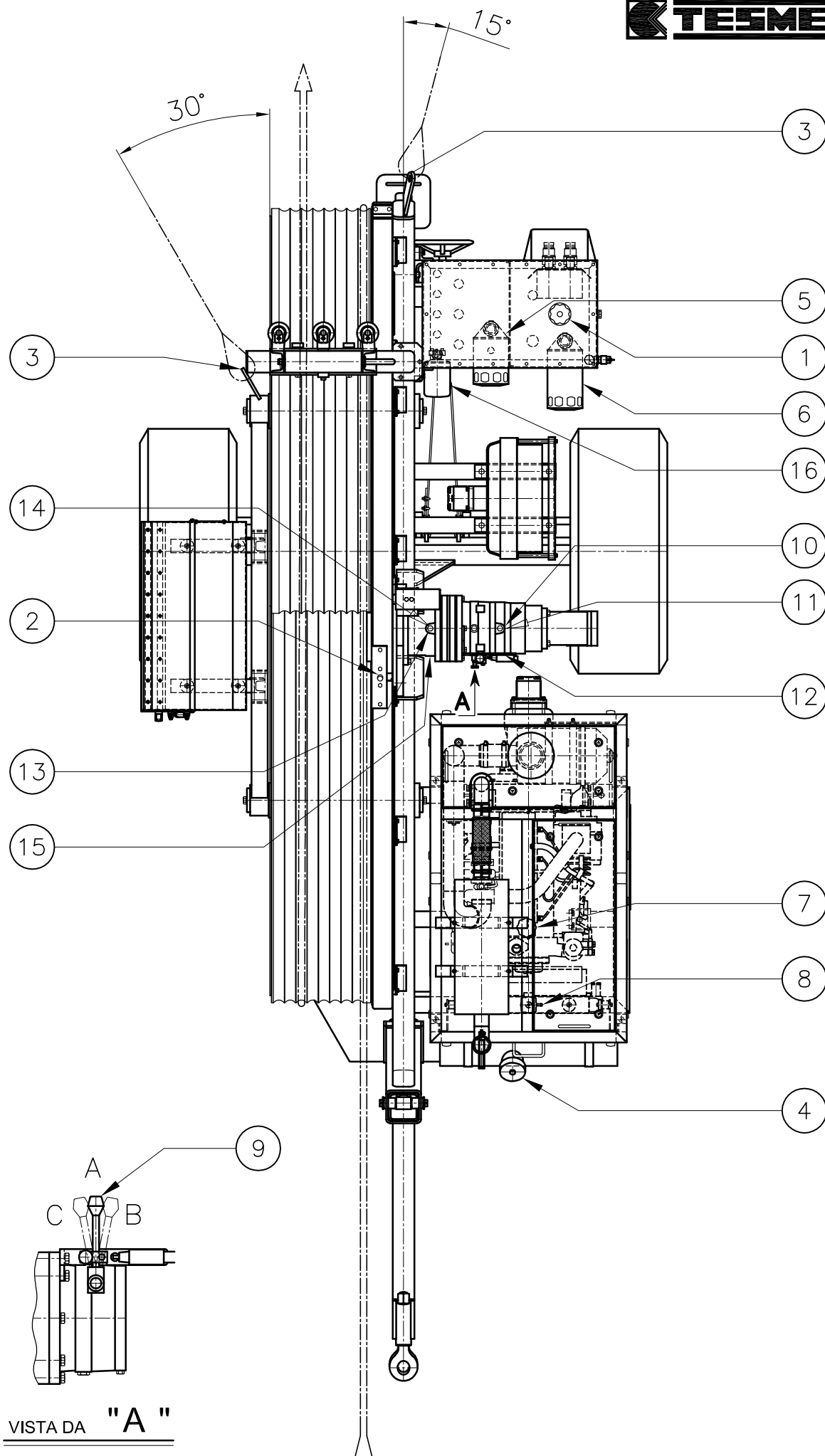
**TABLE 1.5**

- 1) Hydraulic oil level indicator.
- 2) Lifting ear.
- 3) Encoder.
- 4) Fuel filling cap.
- 5) Front plough.
- 6) Towing eye.
- 7)
- 8) Hydraulic oil filling cap (IP HYDRUS OIL 46, qty 180 lt.).
- 9) Hand-wheel for parking brake.
- 10) Rear stabiliser in working position.
- 11) Rear stabiliser in transport position.
- 12) Tools/battery box.
- 13) Hydraulic oil draining cock.



**TABLE 2.5**

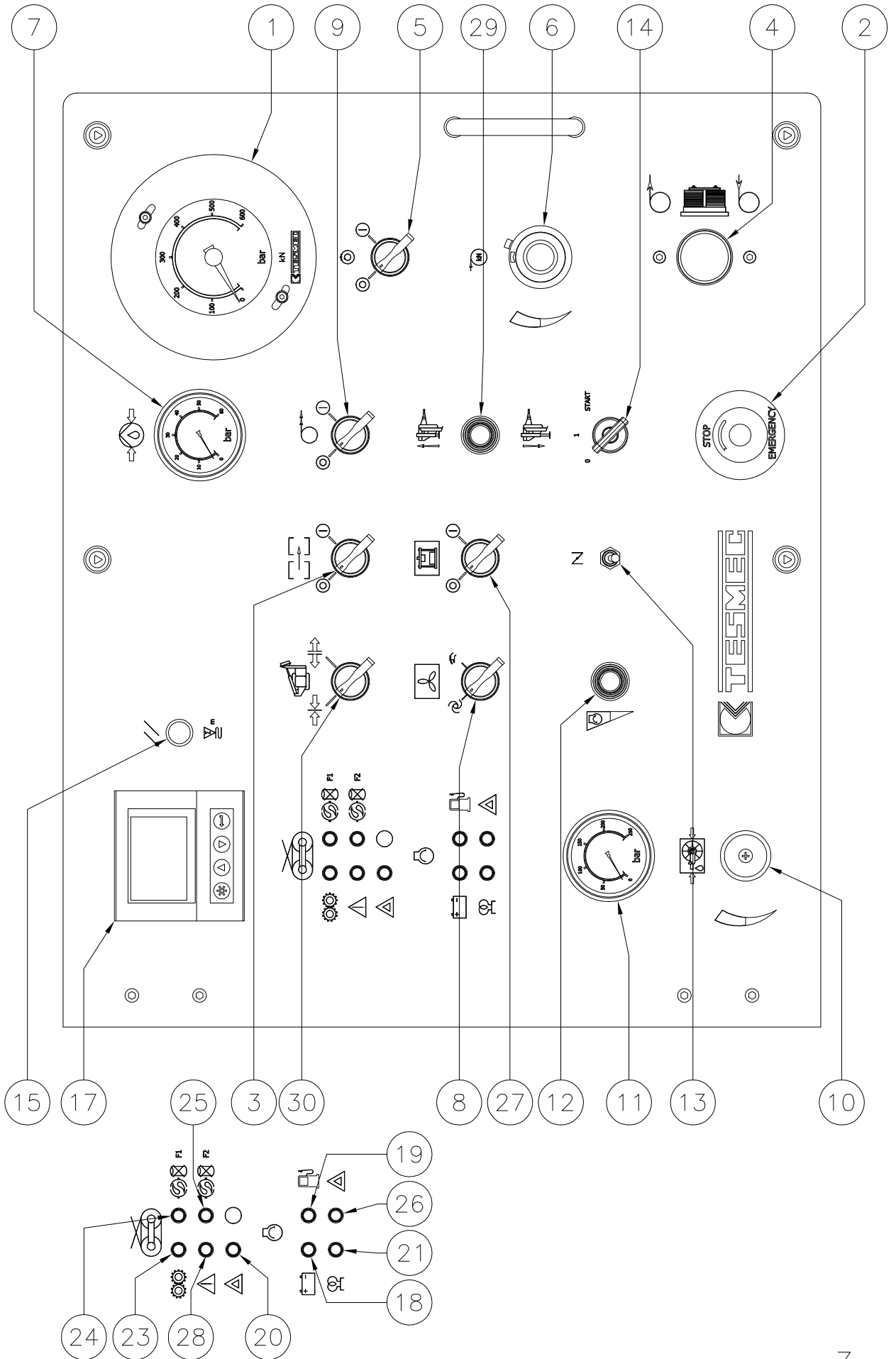
- 1) Hydraulic oil filling cap (IP HYDRUS OIL 46, qty 180 lt.).
- 2) Crown-pinion lubricator.
- 3) Anchoring ears.
- 4) Fuel filling cap.
- 5) Filter.
- 6) Filter.
- 7) Oil filling cap for diesel engine.
- 8) Liquid filling cap for diesel engine radiator.
- 9) Lever for reduction gear speed change (pos. A: neutral, pos. B: fine braking, pos. C: normal braking).
- 10) Negative brake oil filling cap (IP HYDRUS OIL 46, qty 0.3 lt.).
- 11) Negative brake oil draining plug.
- 12) Negative brake oil level.
- 13) Reduction gear oil filling cap (IP MELLANA-220, qty 1.6 lt.).
- 14) Reduction gear oil draining plug.
- 15) Reduction gear oil level.
- 16) Compressor filter (optional).



VISTA DA "A"

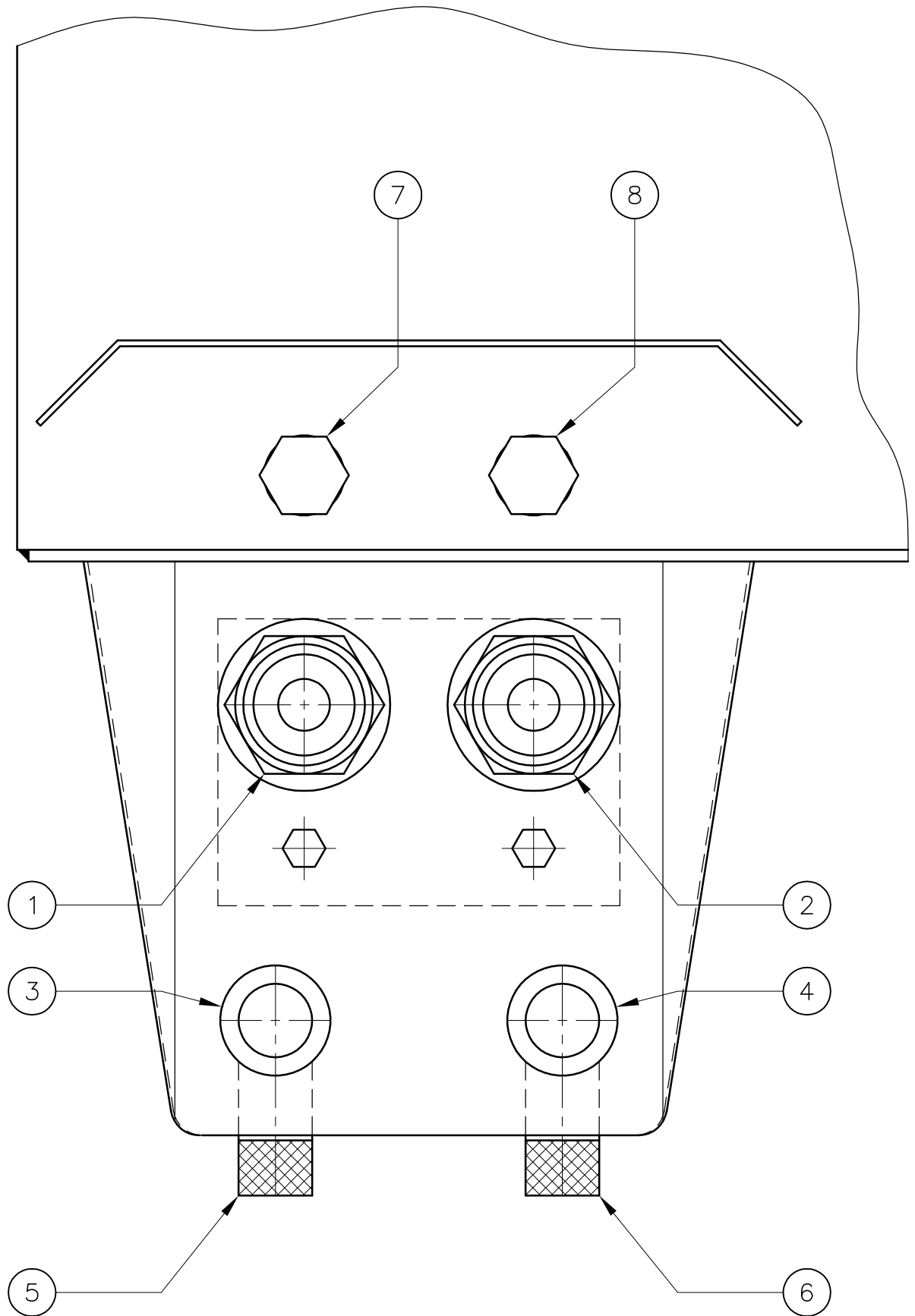
**TABLE 3.6**

- 1) Manometer with graduated ring nut.
- 2) Emergency stop push button.
- 3) Connected machines selector (optional)
- 4) Bull-wheels control lever.
- 5) Pull value setting device.
- 6) Pull value setting knob.
- 7) Manometer for overfeeding pressure.
- 8) Fan function selector.
- 9) Speed synchronizer selector (optional).
- 10) Adjusting valve for reel elevator/reel winder pressure.
- 11) Manometer for reel elevator/reel winder pressure.
- 12) Diesel engine accelerator.
- 13) IPO push button.
- 14) Diesel engine ignition key.
- 15) Meter-counter capstans reset push-button.
- 16)
- 17) Multi-functional display.
- 18) Generator lamp.
- 19) Fuel pilot lamp.
- 20) Pilot lamp for electric pull limiting device exceeding.
- 21) Pre-heating glow plugs lamp.
- 22)
- 23) Fine braking pilot lamp.
- 24) F1 filter pilot lamp.
- 25) F2 filter pilot lamp.
- 26) Engine ALARM pilot light
- 27) Selector for compressor connection (optional).
- 28) Alarm lamp card.
- 29) Lever for front plough movement.
- 30) Rope locking device selector (optional).



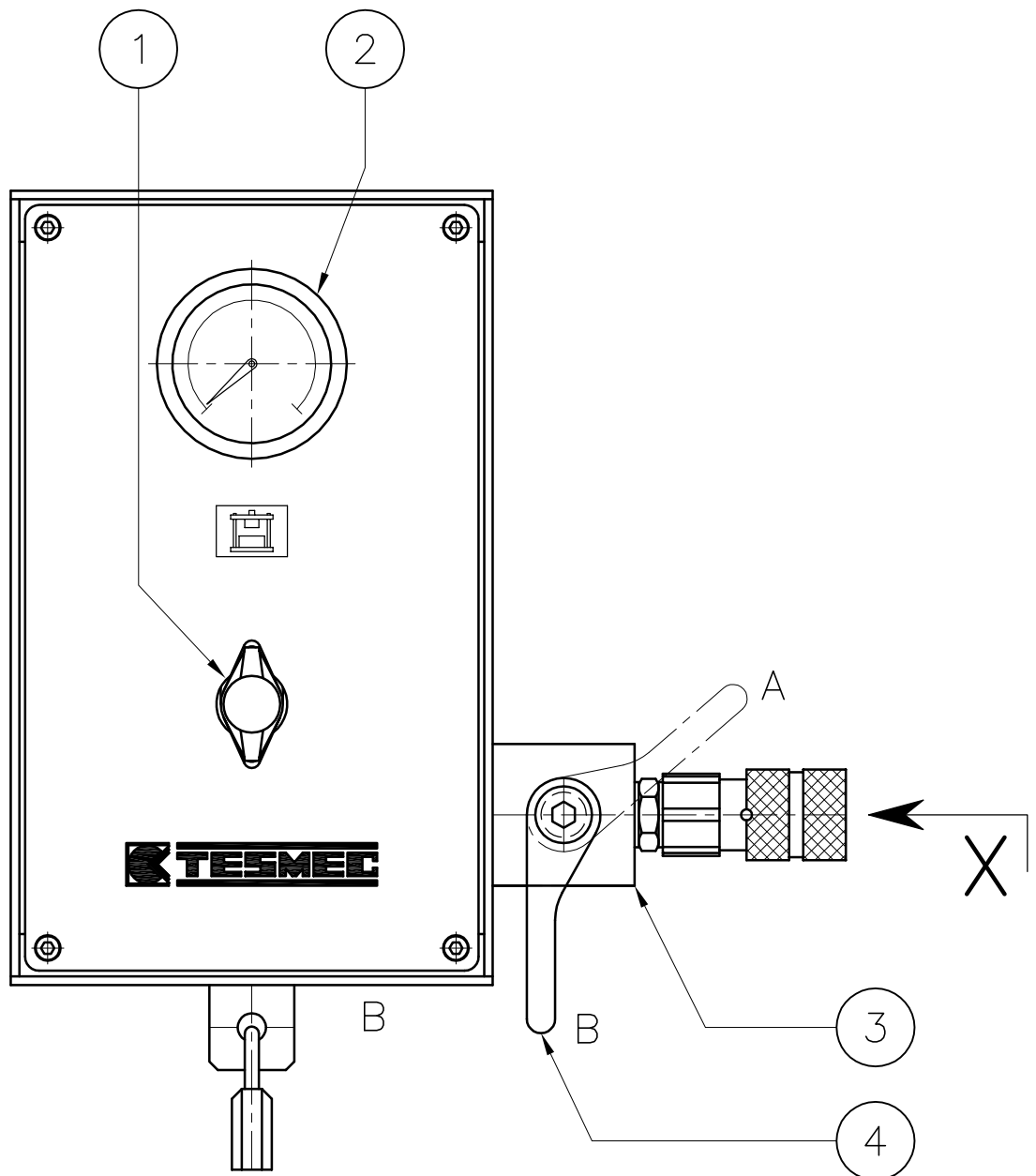
**TABLE 5.1**

- 1) Rapid coupler for return hose connection of hydraulic head no. 1.
- 2) Rapid coupler for return hose connection of hydraulic head no. 2.
- 3) Rapid coupler for delivery hose connection of hydraulic head no. 1.
- 4) Rapid coupler for delivery hose connection of hydraulic head no. 1.
- 5) Adjusting cocks for hydraulic head capacity.
- 6) Adjusting cocks for hydraulic head capacity.
- 7) Draining connection for hydraulic head no. 1 (optional).
- 8) Draining connection for hydraulic head no. 2 (optional).

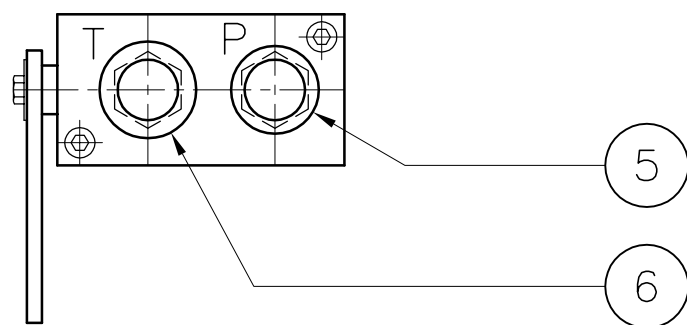


**TABLE 6.2 (OPTIONAL)**

- 1) Pressure adjusting valve.
- 2) Manometer.
- 3) Valve block.
- 4) Opening/closing lever for compressor feeding (pos. A: compressor connection, pos. B: compressor release).
- 5) Rapid coupler for high pressure.
- 6) Rapid coupler for low pressure.



VISTA DA "X"





# Comparative table of suggested oils and greases

TYPE	HYDRAULIC CIRCUIT OIL FOR ENVIROMENTAL CONDITION:				REDUCTION UNIT - COUPLERS REDUCTION UNIT OIL FOR ENVIROMENTAL CONDITION:				GREASING
	ARTIC	WINTER	SUMMER	TROPICAL	ARTIC	WINTER	SUMMER	TROPICAL	GREASE FOR EACH AMBIENT
<b>VISCOSITY (ISO 3448)</b>	VG 22	VG 32	VG 46	VG 68	VG 100	VG 150	VG 220	VG 320	NLGI 2
<b>AGIP</b>	OSO 22	OSO 32	OSO 46	OSO 68	BLASIA 100	BLASIA 150	BLASIA 220	BLASIA 320	GR MU EP 2
<b>API</b>	APILUBE CIS 22	APILUBE CIS 32	APILUBE CIS 46	APILUBE CIS 68	DT 100	DT 150	DT 220	DT 320	PGX 2
<b>ARAL</b>	ARAL VITAM GF 22	ARAL VITAM GF 32	ARAL VITAM GF 46	ARAL VITAM GF 68	DEGOL BG 100	DEGOL BG 150	DEGOL BG 220	DEGOL BG 320	ARALUB HL 2
<b>AVIA</b>	AVILUB RSL 22	AVILUB RSL 32	AVILUB RSL 46	AVILUB RSL 68	AVILUB RSX 100	AVILUB RSX 150	AVILUB RSX 220	AVILUB RSX 320	-
<b>BP</b>	ENERGOL HLP 22	ENERGOL HLP 32	ENERGOL HLP 46	ENERGOL HLP 68	ENERGOL GR-XP 100	ENERGOL GR-XP 150	ENERGOL GR-XP 220	ENERGOL GR-XP 320	GREASE LTX 2
<b>CASTROL</b>	HYSPIIN AWS 22	HYSPIIN AWS 32	HYSPIIN AWS 46	HYSPIIN AWS 68	ALPHA SP 100	ALPHA SP 150	ALPHA SP 220	ALPHA SP 320	SUPERGREASE 2
<b>CHEVRON</b>	EP HYDRAULIC 22	EP HYDRAULIC 32	EP HYDRAULIC 46	EP HYDRAULIC 68	COMPOUND GEAR 100	COMPOUND GEAR 150	COMPOUND GEAR 220	COMPOUND GEAR 320	DURALITH EP 2
<b>ELF</b>	ELFOLNA DS 22	ELFOLNA DS 32	ELFOLNA DS 46	ELFOLNA DS 68	REDUCTELF SP 100	REDUCTELF SP 150	REDUCTELF SP 220	REDUCTELF SP 320	ROLEXA 2
<b>ESSO</b>	NUTO H 22	NUTO H 32	NUTO H 46	NUTO H 68	SPARTAN EP 100	SPARTAN EP 150	SPARTAN EP 220	SPARTAN EP 320	BEACON 2
<b>FINA</b>	HYDRAN 22	HYDRAN 32	HYDRAN 46	HYDRAN 68	GIRAN 100	GIRAN 150	GIRAN 220	GIRAN 320	MARSON EP L2
<b>FUCHS</b>	RENOLIN MR 5	RENOLIN MR 10	RENOLIN MR 15	RENOLIN MR 20	-	RENEP COMPOUND 104	-	RENEP COMPOUND 108	-
<b>GULF</b>	HARMONY 22 AW	HARMONY 32 AW	HARMONY 46 AW	HARMONY 68 AW	-	EP LUBRICANT HD 150	EP LUBRICANT HD 220	EP LUBRICANT HD 320	CROWN EP 2
<b>IP</b>	HYDRUS OIL 22	HYDRUS OIL 32	HYDRUS OIL 46	HYDRUS OIL 68	MELLANA 100	MELLANA 150	MELLANA 220	MELLANA 320	ATHESIA EP GR 2
<b>KLUBER</b>	LAMORA 22	LAMORA 32	LAMORA 46	LAMORA 68	LAMORA 100	LAMORA 150	LAMORA 220	LAMORA 320	CENTOPLEX 2 EP
<b>MOBIL</b>	DTE 22	DTE 24	DTE 25	DTE 26	-	MOBILGEAR 629	MOBILGEAR 630	MOBILGEAR 632	MOBILUX EP 2
<b>Q8</b>	HAYDIN 22	HAYDIN 32	HAYDIN 46	HAYDIN 68	GOYA 100	GOYA 150	GOYA 220	GOYA 320	REMBRANDT EP 2
<b>ROLOIL</b>	LI 22	LI 32	LI 46	LI 68	EP 100	EP 150	EP 220	EP 320	LITEX EP 2
<b>SHELL</b>	TELLUS 22	TELLUS 32	TELLUS 46	TELLUS 68	OMALA 100	OMALA 150	OMALA 220	OMALA 320	SUPERGREASE EP2
<b>SYNECO</b>	-	PACEMAKER 32	PACEMAKER 46	PACEMAKER 68	-	PACEMAKER RODI 12	-	PACEMAKER RODI 24	SINT GREASE EP 2
<b>TAMOIL</b>	HYDRAULIC OIL 22	HYDRAULIC OIL 32	HYDRAULIC OIL 46	HYDRAULIC OIL 68	CARTER EP 100	CARTER EP 150	CARTER EP 220	CARTER EP 320	TAMLITH GREASE EP2
<b>TEXACO</b>	RANDO HD 22	RANDO HD 32	RANDO HD 46	RANDO HD 68	MEROPA 100	MEROPA 150	MEROPA 220	MEROPA 320	MULTIFAK EP 2
<b>TOTAL</b>	AZOLLA ZS 22	AZOLLA ZS 32	AZOLLA ZS 46	AZOLLA ZS 68	CARTER EP 100	CARTE EP 150	CARTER EP 220	CARTER EP 320	MULTIS EP 2
<b>VALVOLINE</b>	ELIOS HVI 22	ELIOS HVI 32	ELIOS HVI 46	ELIOS HVI 58	ELIOS EP 100	ELIOS EP 150	ELIOS EP 220	ELIOS EP 320	LITHIUM BASE EP 2



---

PULLER-TENSIONER MOD. AFS404

*ENCLOSED DOCUMENTS*

---



- 24050 Grassobbio (Bg) via Zanica, 17/O  
Tel. 0039 / 035 / 4232911  
Telefax 0039 / 035 / 4522445  
E-mail: info@tesmec.it

- 24060 Endine Gaiano (Bg) via Pertegalli  
Tel. 0039 / 035 / 825024  
Telefax 0039 / 035 / 826375  
E-mail: info@tesmec.it

## **IMPORTANTE**

*Per qualsiasi informazione riguardante questa macchina/attrezzatura (utilizzo, manutenzione, ricambi) citare sempre Modello, Numero di matricola, Commessa, Anno di fabbricazione rilevabile nella targa d'identificazione della macchina.*

Questo manuale non descrive le procedure di tesatura, né si è cercato di dare istruzioni all'utilizzatore sui metodi di tesatura.

Il contenuto di questo manuale prevede unicamente un testo di base per l'uso, manutenzione e l'elenco dei pezzi di ricambio della macchina stessa e come s'intende e si suggerisce di utilizzarla. Saranno graditi suggerimenti da parte degli Utilizzatori per migliorare questa pubblicazione. Scriveteci all'indirizzo sotto indicato.

## **IMPORTANT NOTE**

*State always "Model, Serial Number and Manufacturing Year" of the machine/equipment in case you need information on use, maintenance and spare parts. The a/m data can be found on the identification plate of the machine itself.*

This is not a stringing procedures manual, and no attempt is made or implied herein to instruct the user in stringing methods.

The contents of this manual are intended as base line for operation, maintenance and part list of the unit as it stands alone and as it is intended and anticipated to be used. Recommendation by the individual user for improving this publication is encouraged and should be forwarded to the address on this page.

## **IMPORTANT**

*Indiquer toujours le modèle, le numéro de série et l'année de fabrication de la machine/équipement même, en demandant à TESMEC renseignements sur l'utilisation, l'entretien et les pièces de rechange. Ces informations se trouvent sur la plaque d'identification de la machine.*

Ce manuel ne décrit pas les procédures de déroulage, ni on a tâche de donner instructions à l'Utilisateur sur les méthodes de déroulage.

Le contenu de ce manuel prévoit seulement un texte pour l'utilisation, l'entretien et la liste de pièces de rechange et comme TESMEC conseille d'utiliser la machine même. Pour chaque suggestion pour améliorer cette machine, écrire à l'adresse au-dessous.

## **IMPORTANTE**

*Para cualquier información relativa a esta máquina/equipo (utilización, mantenimiento, repuestos) citar siempre Modelo, Número de serie, Orden de compra, Año de fabricación que se hallan en la tarjeta de identificación de la máquina.*

Este manual no describe los procedimientos de tensado y tampoco se ha tratado de dar instrucciones al utilizador acerca de los métodos de tensado. El contenido de este manual prevé únicamente un texto básico para el uso, mantenimiento y el listado de repuestos de la misma máquina y cómo se pretende y se sugiere utilizarla. Se apreciarán sugerencias por parte de los utilizadores para mejorar esta publicación. Nos pueden escribir a la dirección indicada abajo.

## **IMPORTANTE**

*Para qualquer informação a respeito desta máquina/equipamento (utilização, manutenção, peças sobresselentes) citar sempre o Modelo, o Número de Série, a Encomenda, o Ano de fabrico, dados que podem ser encontrados na placa de identificação da máquina.*

Este manual não descreve os procedimentos de entesadura, tão pouco foi nossa intenção dar instruções ao utilizador sobre os métodos de entesadura. O conteúdo deste manual de instruções prevê unicamente um texto básico para o uso, a manutenção e a lista das peças sobresselentes da mesma máquina e como se entende e se sugere utilizá-la.

Serão muito bem aceitas sugestões por parte dos Utilizadores, no intento de melhorar esta publicação.

Escrevam-nos no endereço abaixo indicado.

## **WICHTIG**

*Geben Sie für alle Informationen über diese Maschine/Ausrüstung (Verwendung, Wartung, Ersatzteile) immer Modell, Matrikel nummer, Bestellung und Baujahr an, was Sie dem Identifizierungsschild der Maschine entnehmen können.*

Dieses Handbuch beschreibt nicht die Verfahren des Spannsens, und es wurde auch nicht versucht, dem Verwender Anleitungen über die Methoden des Spannsens zu geben. Der Inhalt dieses Handbuchs enthält allein einen Basistext für den Gebrauch und die Wartung, die Ersatzteilliste der Maschine und außerdem, welche Verwendung für sie bezweckt und empfohlen wird.

Wir freuen uns über Tipps von Seiten der Verwender, um diese Veröffentlichung zu verbessern.

Schreiben Sie uns an unten angegebene Adresse.

## **ВАЖНОЕ ПРИМЕЧАНИЕ**

*Всегда следует указывать «модель, серийный номер и год выпуска» машины/оборудования в случае, если вам необходима информация по эксплуатации, техническому обслуживанию и запасным частям. Вышеупомянутые данные можно найти на паспортной табличке на самой машине.*

Руководство по эксплуатации не является руководством по методикам натяжения, и в нем не делается никаких попыток инструктирования пользователя способам натяжения, и они не подразумеваются.

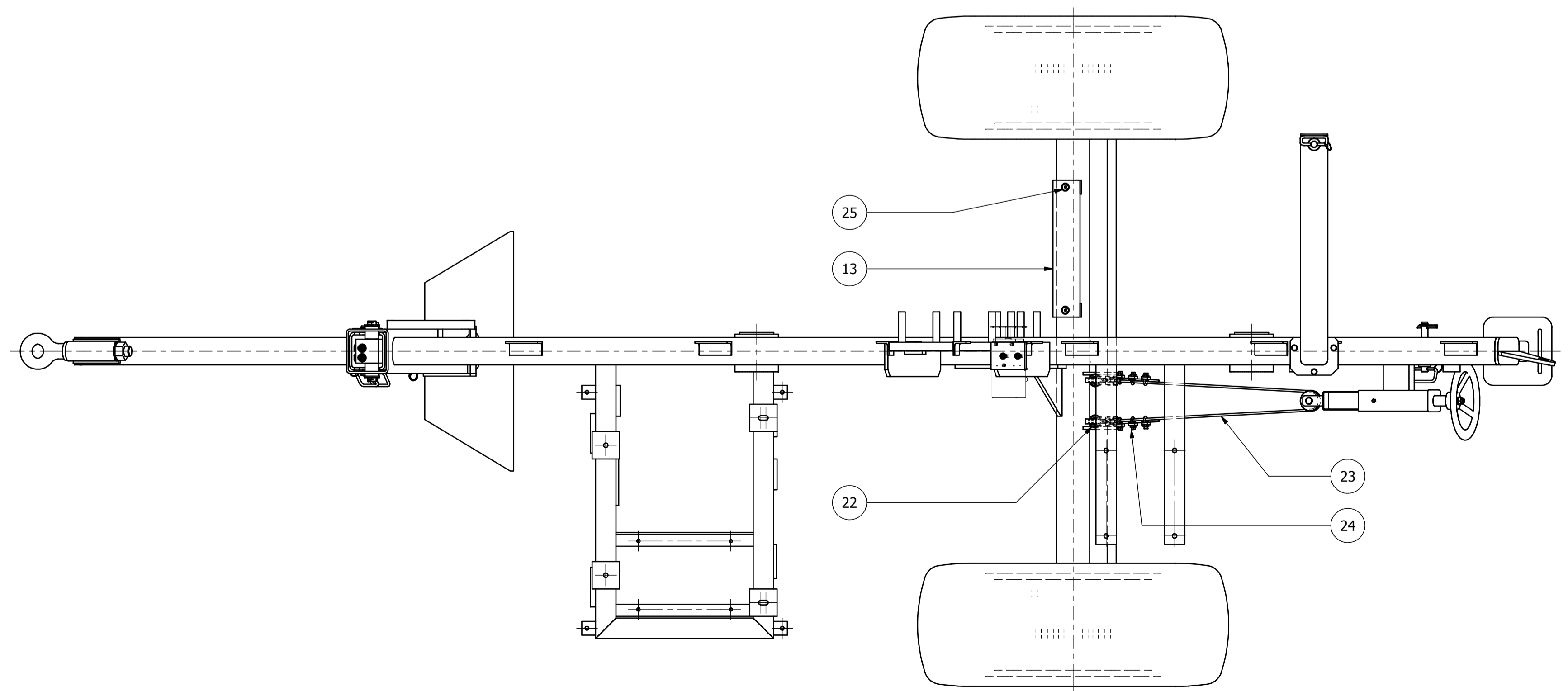
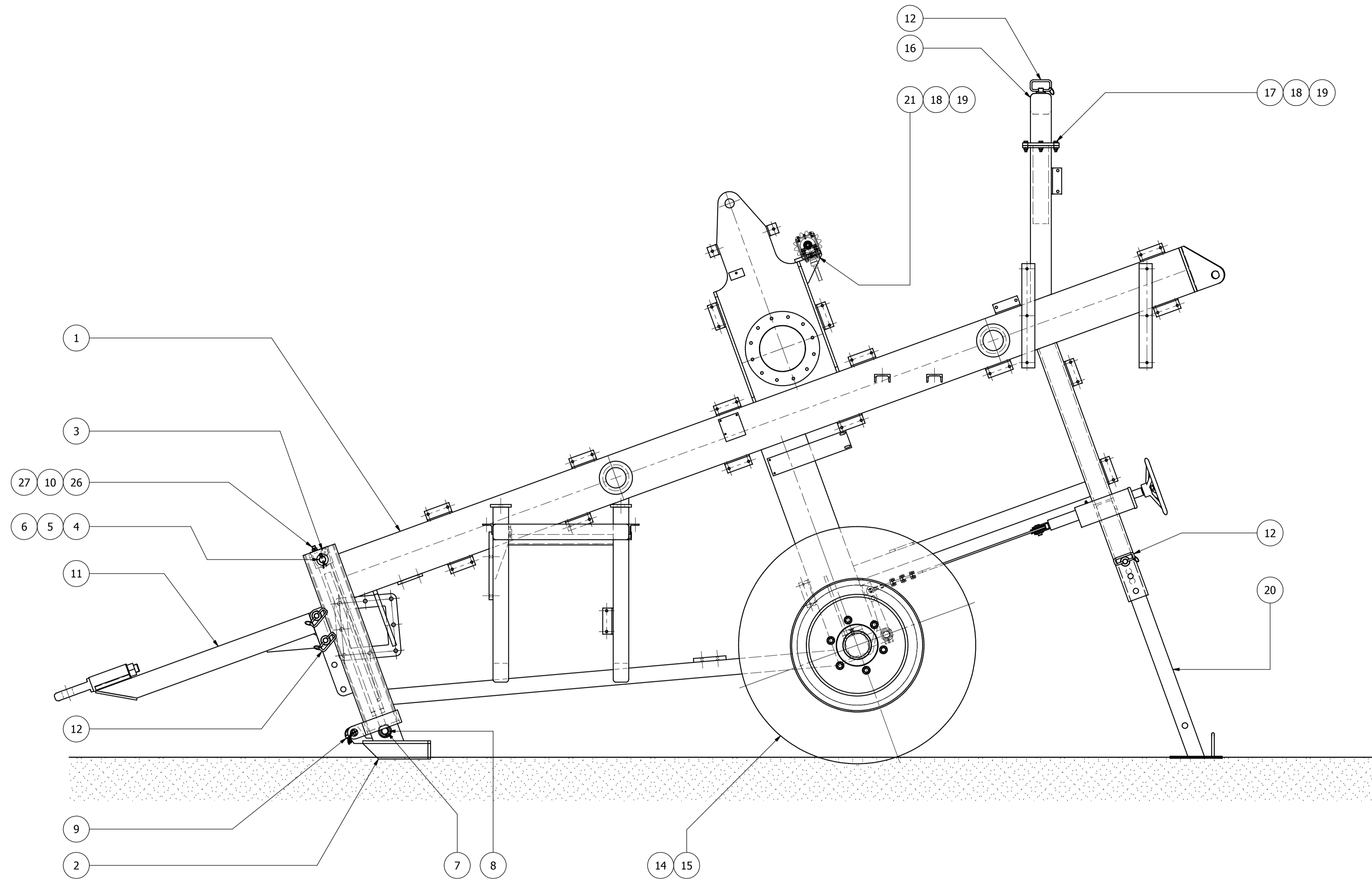
Цель настоящего руководства состоит только в том, чтобы дать описание эксплуатации и технического обслуживания, а также список запасных частей машины, и указать ее назначение и рекомендуемое использование. Рекомендации отдельных пользователей по улучшению данной публикации приветствуются, и их следует направлять по адресу, указанному в руководстве.



- 24050 Grassobbio (Bg) via Zanica, 17/O  
Tel. 0039 / 035 / 4232911  
Telefax 0039 / 035 / 4522445  
E-mail: info@tesmec.it

- 24060 Endine Gaiano (Bg) via Pertegalli  
Tel. 0039 / 035 / 825024  
Telefax 0039 / 035 / 826375  
E-mail: info@tesmec.it

DATE	SYM	REVISION RECORD	DR/CK

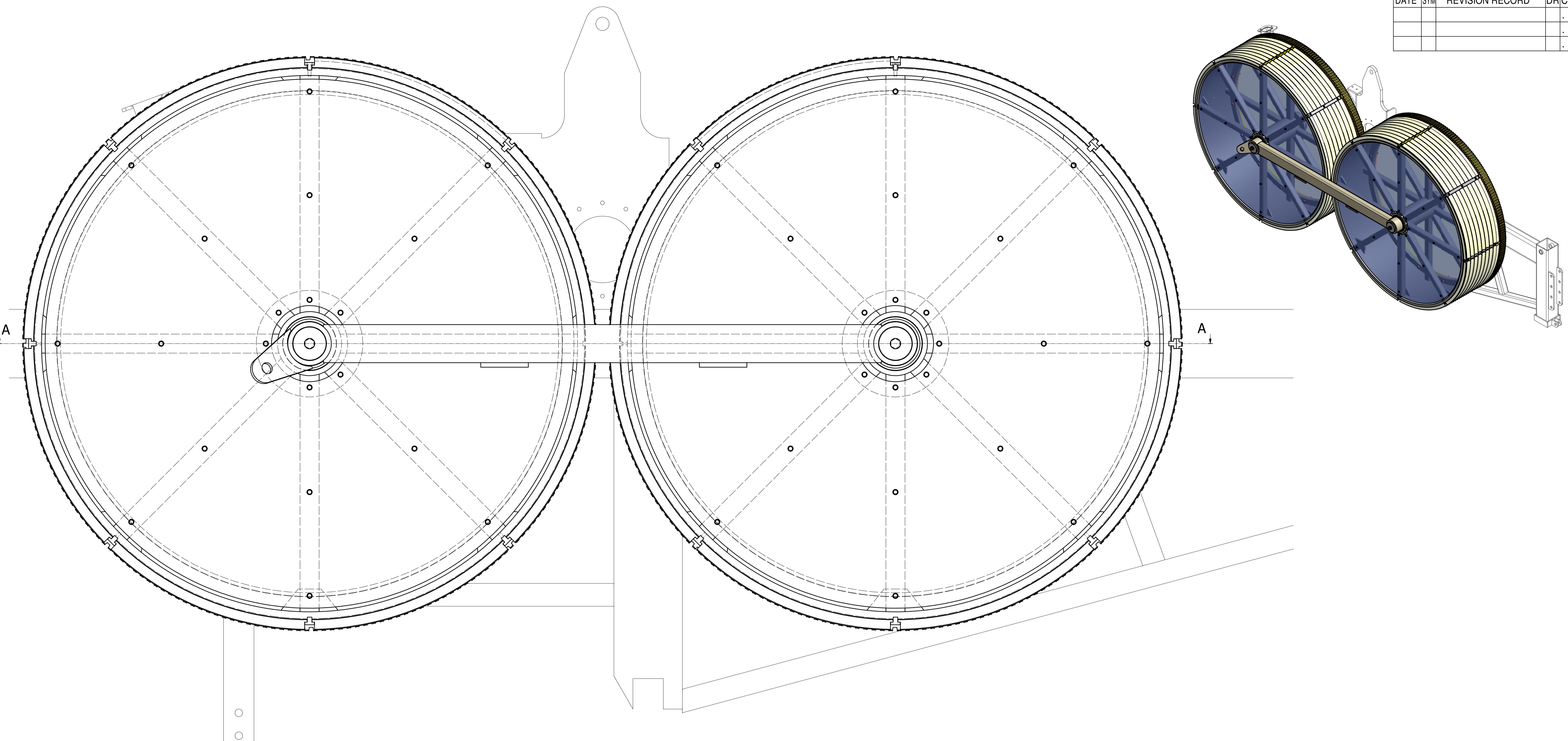


27	D99-10017	GRANO FORATO - 8x12 - FORO ø1 [ ] DOWL	2	0 kg
26	D99-10006	NIPPLO FORATO - 1/4" Gas - FORO M8 [ ] NIPPLE	2	0 kg
25	H58-1010-025	VITE - ISO 10642 - M 10 x 25 - 10.9 - Z - TSEI - PG [ ] BOLT	2	0 kg
24	V00-9000-014	MORSETTO A CAVALOTTO D. 5-6 - AMA : Art.564 [ ] CLAMP	6	0 kg
23	V00-9000-029	FUNE ACCIAIO ZINCATO 114 FILI - D. 6 mm CR= 21.92 kN [ ] CABLE	2	0.4 kg
22	V00-9000-015	REDANZIA PER FUNE - DIN 6899B X FUNE D. 7 [ ] THIMBLE	2	0 kg
21	H56-1008-045	VITE - ISO 4762 - M 8 x 45 - 8.8 - Z - TCEI - PG [ ] BOLT	2	0 kg
20	D00-00315	STABILIZZATORE POSTERIORE 200 x 200 x 862 [ ] STABILIZER	1	9.1 kg
19	H77-1008-011	DADO - UNI 7473 - M 8 - GR. 8 - Z - AUTOB. [ ] LOCKNUT	5	0 kg
18	H81-1008-002	ROSETTA - ISO 7089 - TE - 8 - 100 HV - Z [ ] WASHER	10	0 kg
17	H50-1008-035	VITE - ISO 4017 8 x 35 - GR. 8.8 - Z - TE - PG - I.FIL [ ] BOLT	3	0 kg
16	D00-00311	SUPPORTO RULLI 140 x 500 x 705 [ ] SUPPORT	1	17.4 kg
15	V00-2130-001	PNEUMATICO - 30 Km/h - 13.0/65-18 PR-16 - PORTATA: 3330 Kg - 5.00 bar [ ] TYRE + AIR TUBE	2	33.4 kg
14	V00-2160-001	CERCHIONE - N° 6 Fori - 30 Km/h - 11.00x18 - SPOSTAMENTO: 0 - INTERGOMMA [ ] TIRE RIM	2	30.4 kg
13	D00-00316	PROTEZIONE ASSALE 15 x 80 x 400 [ ] GUARD	1	0.5 kg
12	V00-9020-001	SPINOTTO - AMA : Art.1 D. 19 x lg. 110 - CON CATENELLA E SPINA A SCATTO [ ] PIN	4	0.4 kg
11	D00-00310	TIMONE 80 x 138 x 1071 [ ] RUDDER	1	19.8 kg
10	F11-0003-003	RONDELLA RAME D. 1/4" x 3 [ ] WASHER	2	0 kg
9	V00-9020-010	PERNO x TERZO PUNTO - AMA : Art.178 D. 19 x lg. 120 - CON CATENELLA E SPINA A SCATTO [ ] PIN	1	0.4 kg
8	V00-9010-013	ANELLO - UNI 7435 - 25 - E (SEEGER) [ ] RING	2	0 kg
7	D00-00314	PERNO D. 25 x lg. 108 - SEDE SEEGER [ ] PIN	1	0.4 kg
6	V00-9030-021	COPIGLIA - UNI EN ISO 1234 - D. 6.3 x 40 - SK [ ] COTTER PIN	2	0 kg
5	H81-1024-004	ROSETTA - ISO 7089 - TE - 24 100 HV - Z [ ] WASHER	2	0 kg
4	D00-00313	PERNO D. 25 x lg. 177 - FORO COPIGLIE [ ] PIN	1	0.7 kg
3	V00-6500-061	CILINDRO A: 40 S: 25 C: 500 DIM. CHIUSO: 700 DIM. APERTO: 1200 ATTACCHI: OCCHIO FISSO D.25.5 PORTE: 1/4" Gas - CON VALVOLA [ ] CILYNDER	1	9 kg
2	D00-00312	STABILIZZATORE ANTERIORE 290 x 700 x 907 [ ] STABILIZER	1	34 kg
1	D00-00307	TELAIO COMPLETAMENTO - AFS 404 600 [ ] FRAME	1	402.8 kg
ITEM	CODE	DESCRIPTION	QTY	WEIGHT

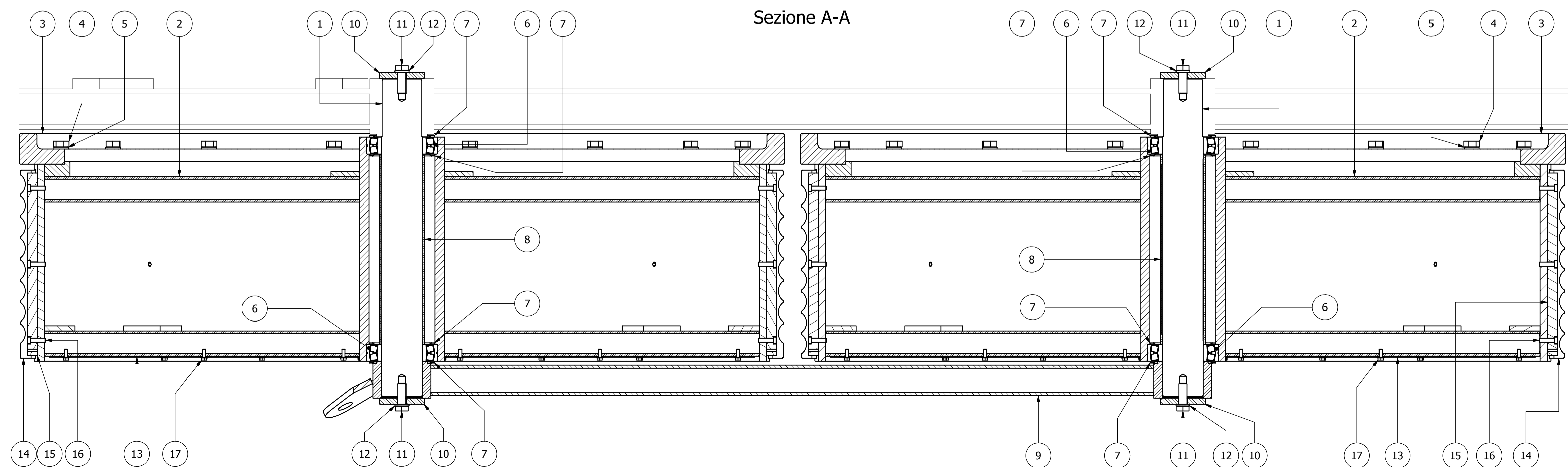
<b>TESMEC</b>		ARGANO FRENO	
GRASSANO (BO) Tel. 052/4232911 - Fax 052/4522445 CHIVRE - (BO) Tel. 052/852024 - Fax 052/852432		AFS 400 600	
TUTTE LE NORME RICHIAMATE SI INTENDONO NELLA LORO ULTIMA EDIZIONE.		ASSIEME TELAIO	
SALDATURE IN ACCORDO CON - WPS 1 s 9		NUMERO DISEGNO	
GRADO DI PRECISIONE PER QUOTE LINEARI, ANGOLARI, GEOMETRICHE NON TOLLERATE		A10-00003	
LAV. MECCANICHE UNI EN 22768 - F H		FOGLIO 1 / 1	
CARPENTERIA UNI EN 22768 - C K		1:10	

Il disegno è proprietà della TESMEC s.p.a. A termini di legge si vieta tassativamente la riproduzione e la divulgazione a terzi.

DATE	SYM	REVISION RECORD	DR/CK



Sezione A-A



ITEM	CODE	DESCRIPTION	QTY	WEIGHT
17	H99-8900-002	VITE 0274 06 16 - M 6 x 16 - 8 - Z - WURTH [ ] BOLT	48	0 kg
16	H99-8900-091	VITE - DIN 7984 - M 8 x 30 8.8 - Z [ ] BOLT	48	0 kg
15	D00-00323	CHIAVETTA PER SETTORI 20 x 25 x 360 [ ] FEATHER KEY	16	0.9 kg
14	D00-00322	SETTORE D. 1505 / 1445 x lg. 371 - N° 8 Gole R. 24 - Dfd. 1485 [ ] SECTOR	16	5.6 kg
13	D00-00324	DISCO CABESTANI D.1390 x 2 [ ] DISC	2	23.3 kg
12	H88-1016-004	ROSETTA - UNI 1751 - A - 16 - Z [ ] WASHER	4	0 kg
11	H50-1016-045	VITE - ISO 4017 - M 16 x 45 - 8.8 - Z - TE - PG - I.FIL [ ] BOLT	4	0.1 kg
10	D00-00319	RONDELLA D. 89 / 17 x Sp. 12 [ ] WASHER	4	0.6 kg
9	D00-00325	TRAVERSA CABESTANI 72 x 114 x 1654 - Int. 1540 - d 80 [ ] CROSS CAPSTANS	1	28 kg
8	D00-00320	DISTANZIALE D. 88.9 / 80 x lg. 375 [ ] SPACER	2	2.6 kg
7	V00-5300-008	ANELLO NILOS - 6216 - 22216 AV [ ] RING	8	0 kg
6	V00-5101-021	CUSCINETTO - SKF : 22216 E - ORIENTABILE A RULLI - d 80 / D 140 x B 33 C= 236 kN Co= 270 kN [ ] BEARING	4	2.1 kg
5	H88-1018-004	ROSETTA-UNI 1751-A18-Z [ ] WASHER	32	0 kg
4	H53-1018-065	VITE - ISO 4014 - M 18 x 65 - 8.8 - Z - TE - PG - P.FIL [ ] BOLT	32	0.2 kg
3	D00-00321	CORONA D. 1508.5 x 60 - Z= 214 - M= 7 / 5.25 [ ] GEAR	2	120.5 kg
2	D00-00317	CABESTANO D. 1451 x lg. 442 [ ] BULL-WHEEL	2	392.4 kg
1	D00-00318	ALBERO CABESTANO D. 80 x lg. 626 [ ] SHAFT	2	24.2 kg

**TESMEC**  
 GRASSANO (BO) Tel. 052/4232911 - Fax 052/4522445  
 CINESE (BO) Tel. 052/952024 - Fax 052/9526325

TUTTE LE NORME RICHIAMATE SI INTENDONO NELLA LORO ULTIMA EDIZIONE.

SALDATURE IN ACCORDO CON - WPS 1-s-9

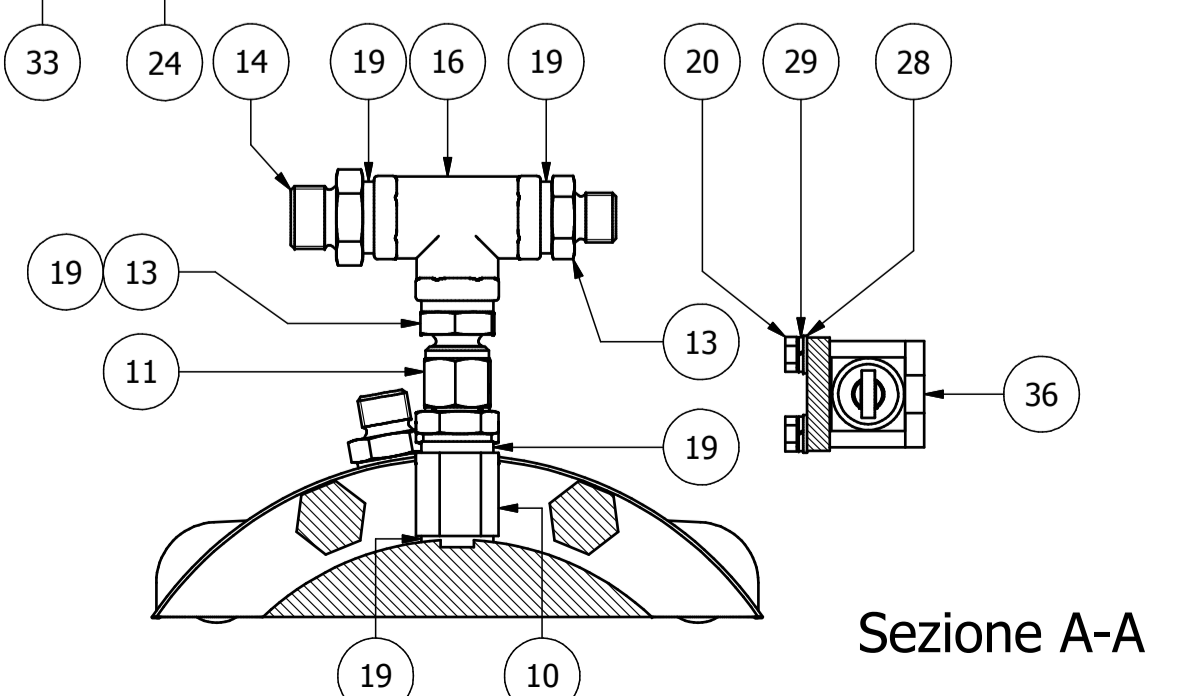
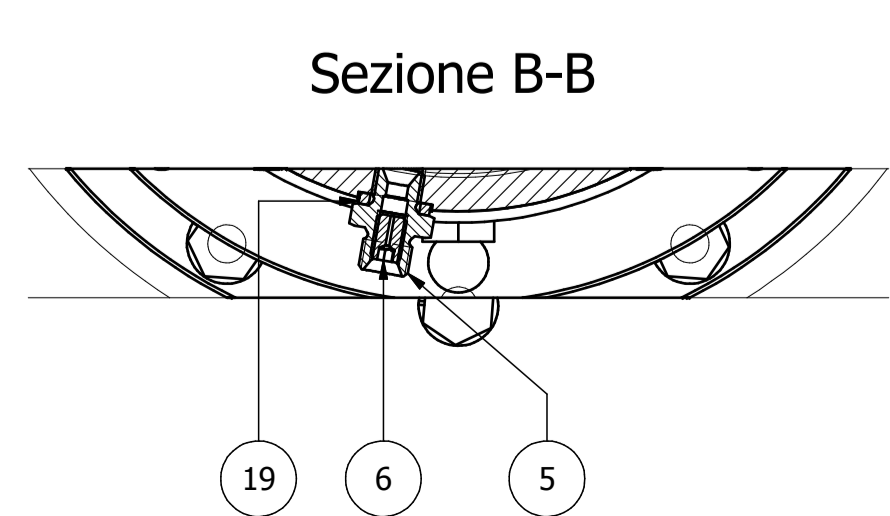
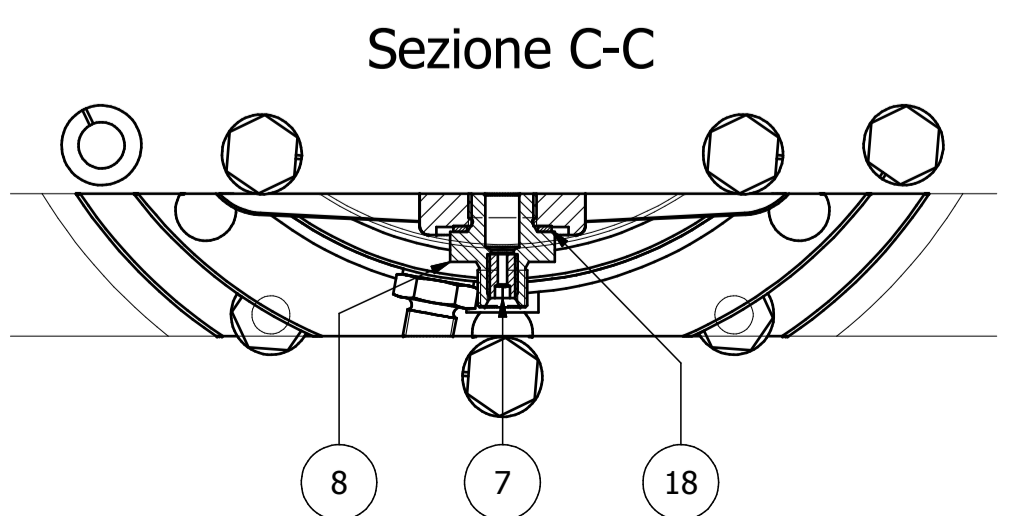
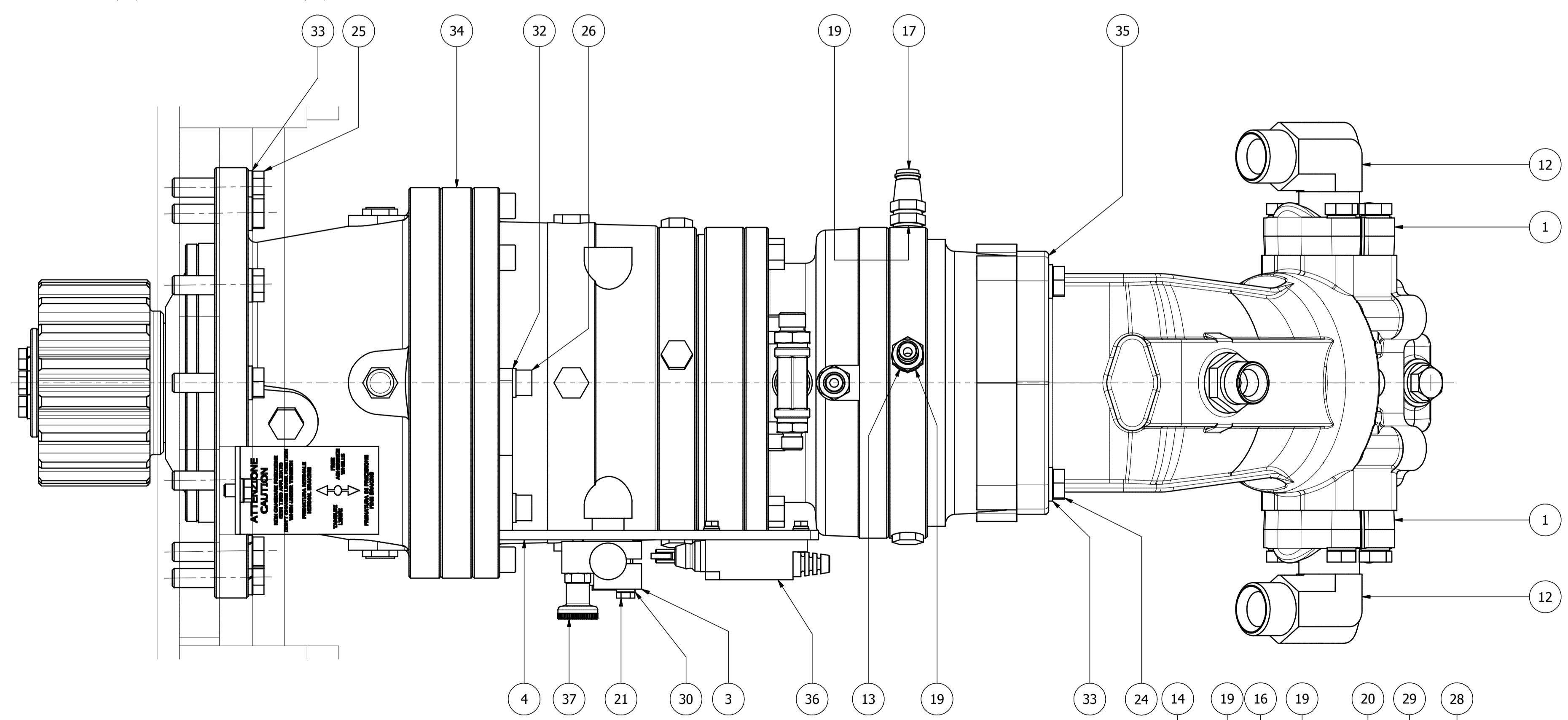
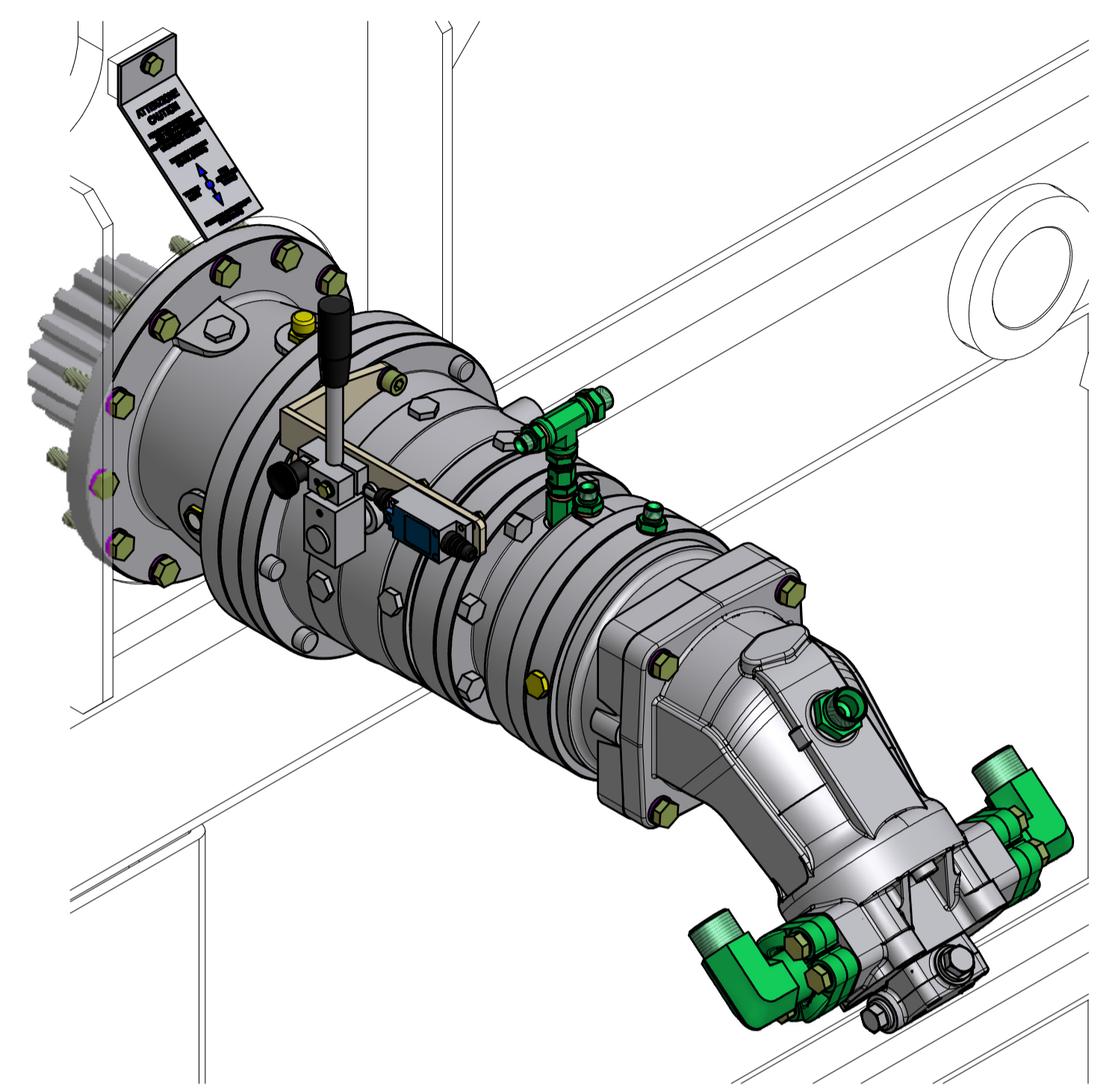
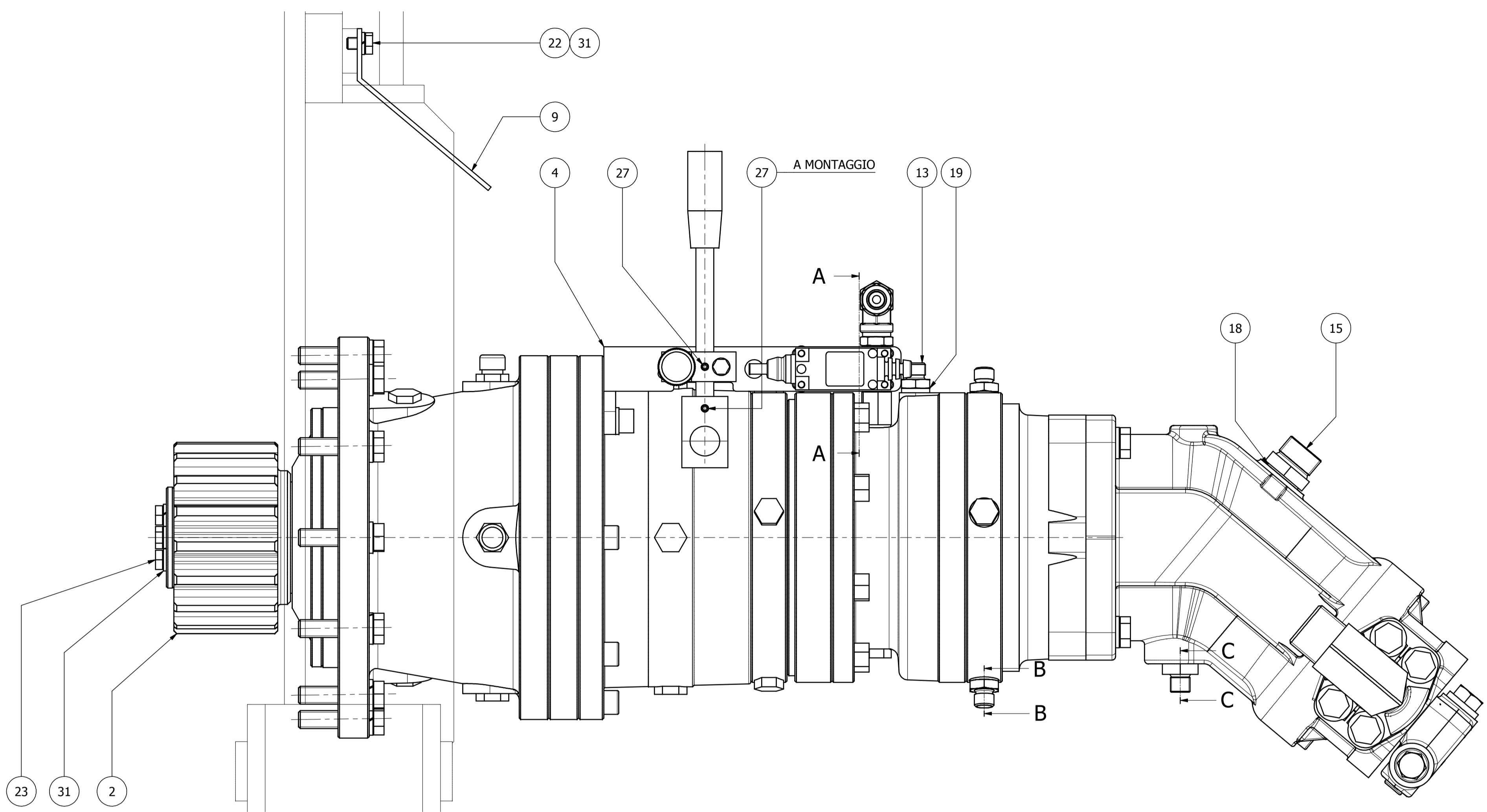
GRADO DI PRECISIONE PER QUOTE LINEARI, ANGOLARI, GEOMETRICHE NON TOLLERATE

LAV. MECCANICHE UNI EN 22768-f H  
 CARPENTERIA UNI EN 22768-c K

ghezzi	ARGANO FRENO
08/09/2009	AFS 404 600
1276,84 kg	ASSIEME CABESTANI
1:5	NUMERO DISEGNO <b>A11-00003</b>

Il disegno è proprietà della TESMEC s.p.a. A termini di legge si vieta tassativamente la riproduzione e la divulgazione a terzi.

DATE	SYM	REVISION RECORD	DRCK

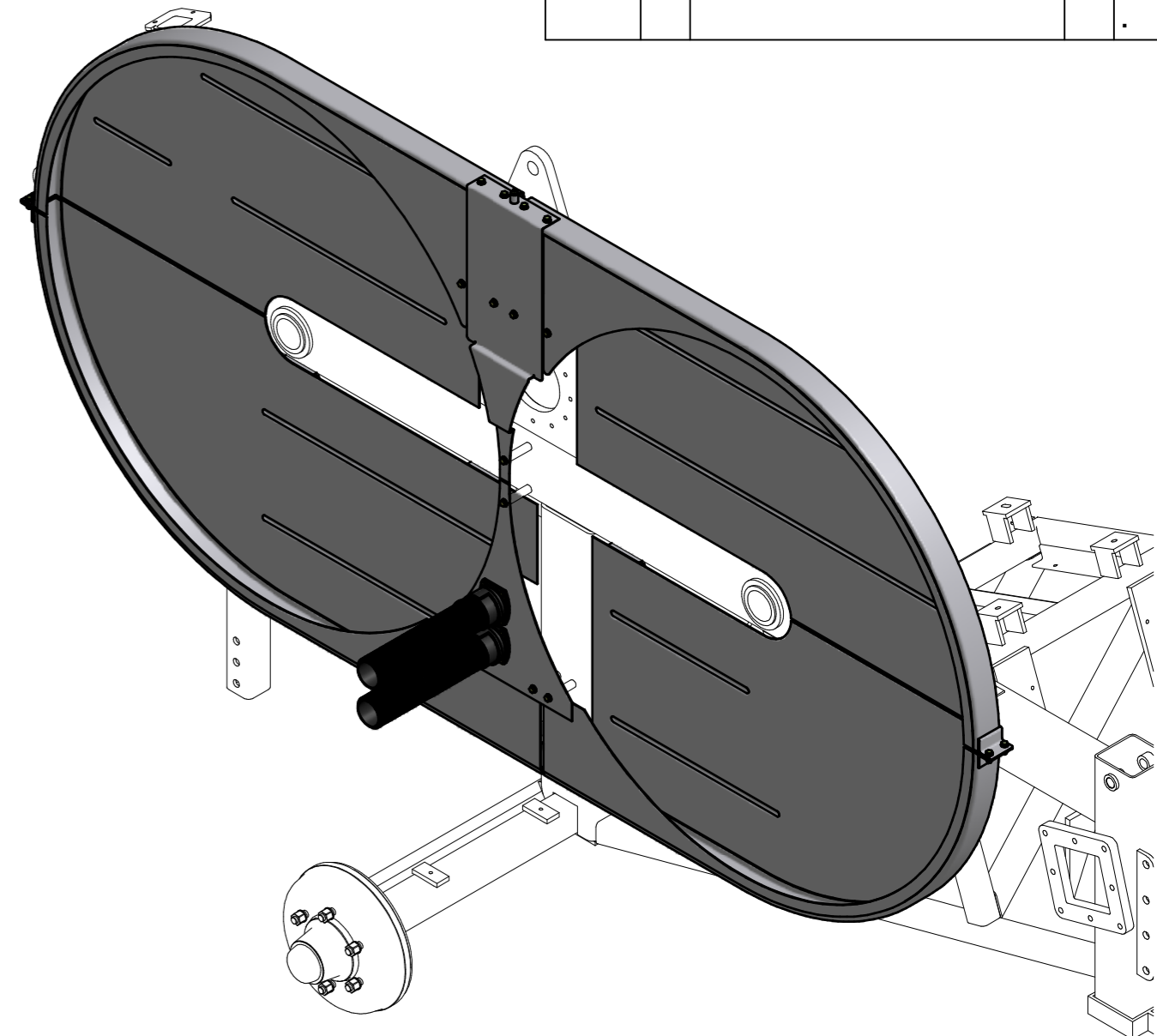
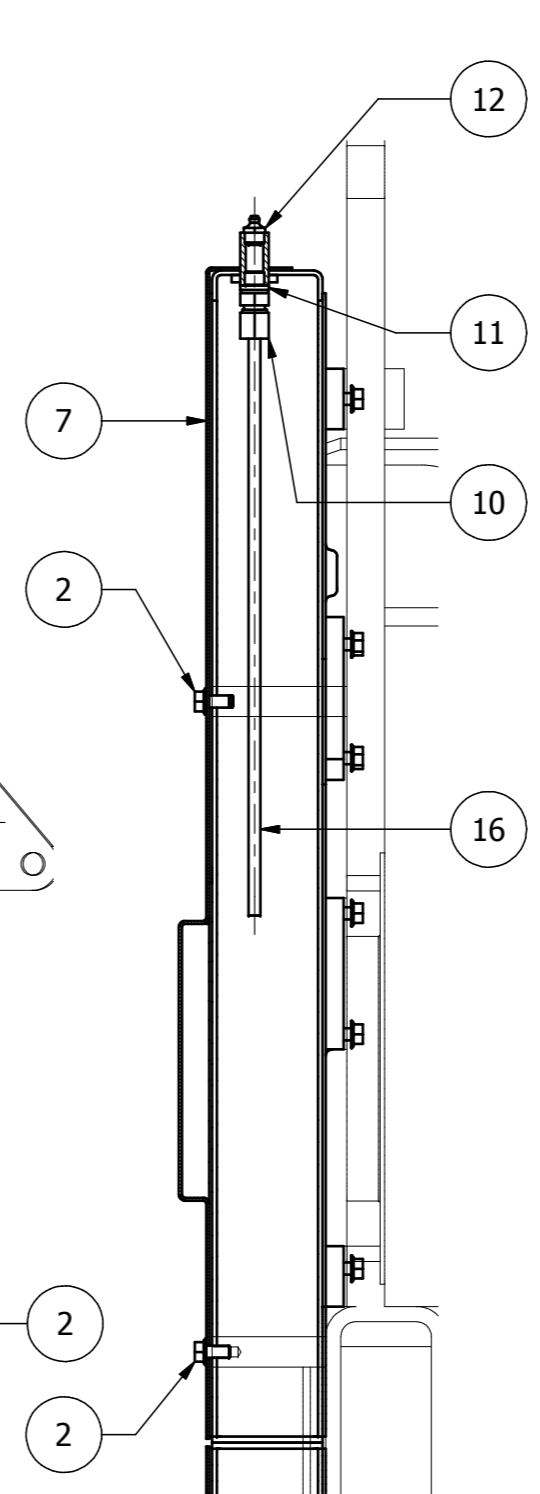
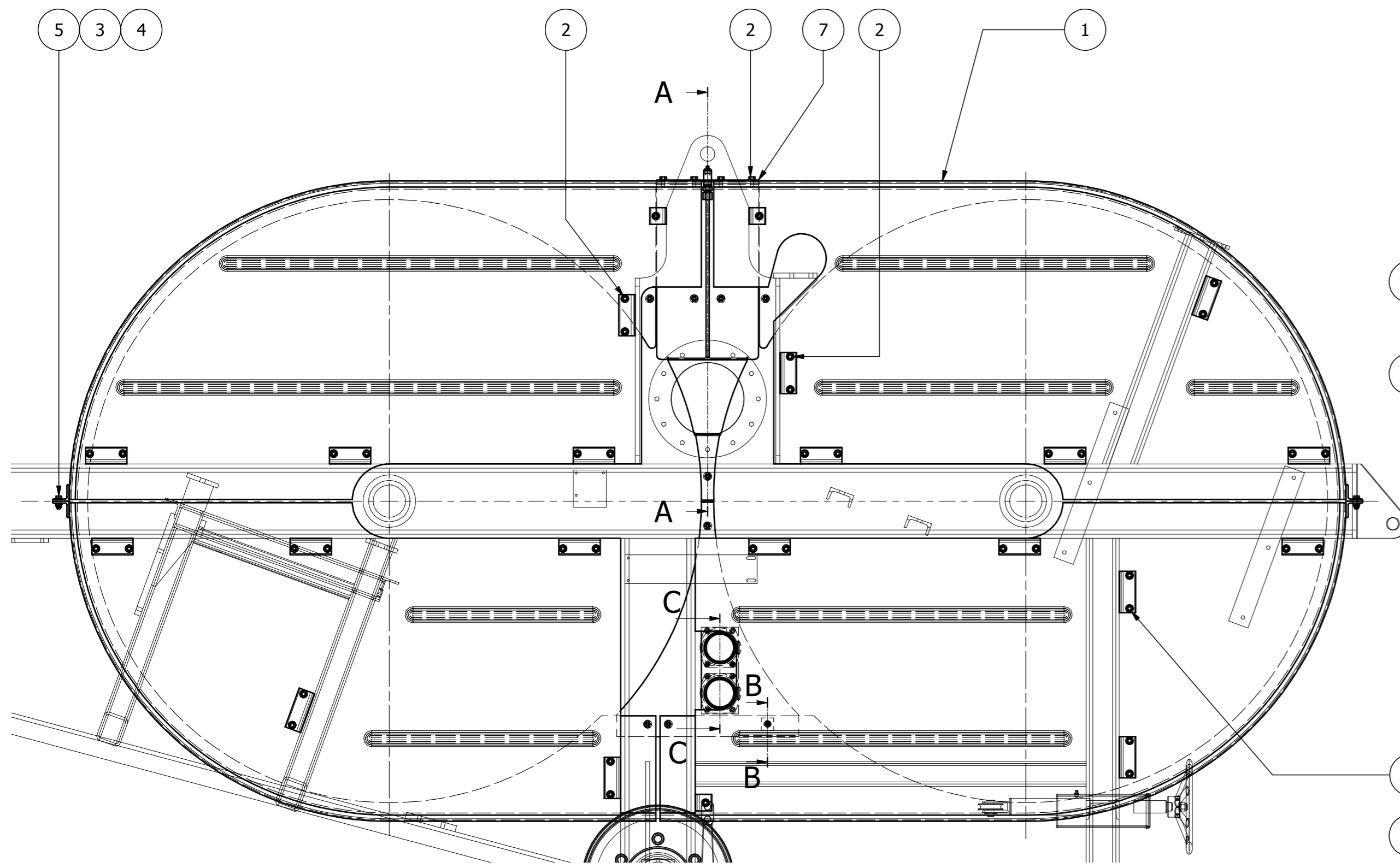


ITEM	CODE	DESCRIPTION	QTY	WEIGHT
37	V00-9040-027	OTTURATORE PISTONCINO A MOLLA - ELESA : GN 617-6-A-NI [ ] SHUTTER	1	0 kg
36	V00-8510-036	FINECORSA A PULSANTE CON ROTELLA - 1 N.A + 1 N.C - 5A-250 VAC [ ] LIMIT SWITCH	1	0.1 kg
35	V00-6050-014	MOTORE IDRAULICO - A2FM 80 61W VAB 027 - REXROTH [ ] MOTOR	1	18 kg
34	V00-5702-009	RIDUTTORE RR 510 SS - R: 7 + CAMBIO - RF 5/65 - A2FM80 [ ] GEARBOX	1	82.2 kg
33	H88-1012-003	ROSETTA - UNI 1751 - A - 12 - Z [ ] WASHER	16	0 kg
32	H88-1010-002	ROSETTA - UNI 1751 - A - 10 - Z [ ] WASHER	2	0 kg
31	H88-1008-002	ROSETTA - UNI 1751 - A - 8 - Z [ ] WASHER	5	0 kg
30	H88-1006-002	ROSETTA - UNI 1751 - A - 6 - Z [ ] WASHER	1	0 kg
29	H88-1005-001	ROSETTA - UNI 1751 - A - 5 - Z [ ] WASHER	4	0 kg
28	H81-1005-001	ROSETTA - ISO 7089 - TE - 5 - 100 HV - Z [ ] WASHER	4	0 kg
27	H61-0005-012	VITE - UNI 5927 - M 5 x 12 45H (12.9) - GRANO ESTEMITÀ CONICA [ ] BOLT	2	0 kg
26	H56-1010-060	VITE - ISO 4762 - M 10 x 60 - 8.8 - Z [ ] BOLT	2	0.1 kg
25	H53-1012-050	VITE - ISO 4014 - M 12 x 50 - 8.8 - Z [ ] BOLT	12	0.1 kg
24	H50-1012-045	VITE - ISO 4017 - M 12 x 45 - 8.8 - Z - TE - PG - I.FIL [ ] BOLT	4	0.1 kg
23	H50-1008-025	VITE - ISO 4017 - M 8 x 25 - 8.8 - Z [ ] BOLT	4	0 kg
22	H50-1008-012	VITE - ISO 4017 - 8 x 12 - GR. 8.8 - Z - TE - PG - I.FIL [ ] BOLT	1	0 kg
21	H50-1006-030	VITE - ISO 4017 - M 6 x 30 - 8.8 - Z - TE - PG - I.FIL [ ] BOLT	1	0 kg
20	H50-1005-016	VITE - ISO 4017 - M 5 x 16 - 8.8 - Z - TE - PG - I.FIL [ ] BOLT	4	0 kg
19	F11-0003-003	RONDELLA RAME D. 1/4" x 3 [ ] WASHER	9	0 kg
18	F11-0001-021	RONDELLA - BONDED - M 18 Sp. 1.5 [ ] WASHER	2	0 kg
17	F10-0001-003	MINIPRESA - ISO228 G 1/4" - FORM E - P MAX 630 bar - MCS : 620.01.204.20 [ ] COUPLING	1	0 kg
16	F05-0003-003	RACCORDO A T FEMMINA - ASA 2000 - 1/4" GAS [ ] FITTING	1	0 kg
15	F04-0006-020	NIPPLO 3/4" GAS - M18x1.5 [ ] NIPPLE	1	0.1 kg
14	F04-0001-017	NIPPLO 3/8" GAS - 1/4" GAS [ ] NIPPLE	1	0 kg
13	F04-0001-003	NIPPLO 1/4" GAS - 1/4" GAS [ ] NIPPLE	4	0 kg
12	F02-0049-010	RIDUZIONE 90° 1" SAE 6000 FL - 1" GAS [ ] FITTING	2	0.8 kg
11	F01-0027-003	ADATTATORE DIRITTO GIREVOLE 1/4" GAS M - 1/4" GAS F [ ] FITTING	1	0 kg
10	F01-0001-016	RIDUZIONE PROLUNGA - 1/4" GAS M - 1/4" GAS F - L. 33 - CH: 19 x lg. 22 [ ] FITTING	1	0 kg
9	D99-90180	TARGA CAMBIO RIDUTTORE 3 x 55 x 150 [ ] PLATE	1	0.1 kg
8	D99-10019	NIPPLO FORATO - 1/4" Gas - M18x1.5 - FORO M8 [ ] NIPPLE	1	0.1 kg
7	D99-10018	GRANO FORATO - 8x12 - FORO ø2.5 [ ] DOWL	1	0 kg
6	D99-10017	GRANO FORATO - 8x12 - FORO ø1 [ ] DOWL	1	0 kg
5	D99-10006	NIPPLO FORATO - 1/4" Gas - FORO M8 [ ] NIPPLE	1	0 kg
4	D00-00328	STAFFA CAMBIO RIDUTTORE 59 x 107.5 x 200 [ ] MOUNTING	1	0.5 kg
3	D00-00327	BLOCCETTO CAMBIO RIDUTTORE 20 x 30 x 50 [ ] MANIFOLD	1	0.2 kg
2	D00-00326	PIGNONE D. 129.5 x 78.5 - Z= 17 - M= 7/5.25 [ ] SPROCKET	1	4.9 kg
1	A99-10062	ASSIEME SEMIFLANGIE SAE 6000 1" [ ] ASSEMBLY	2	0.7 kg

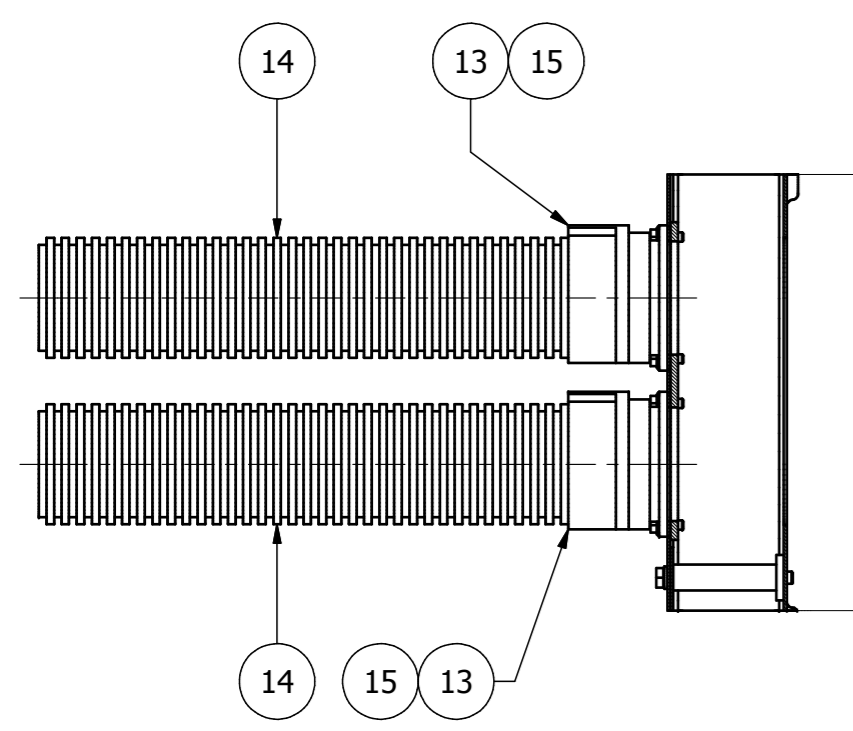
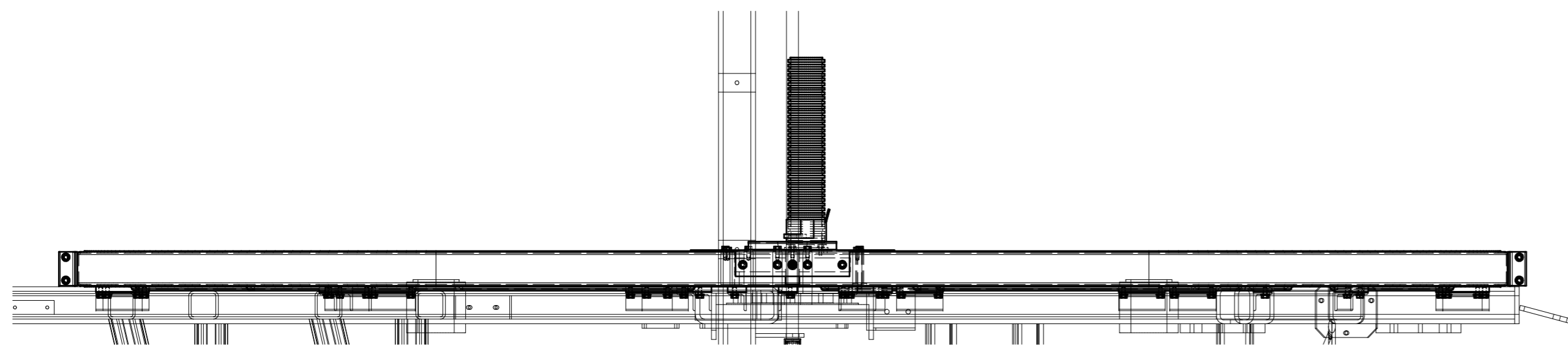
		<b>ARGANO FRENO</b> Ghezzi B.	
GRASSORBITO (BG) Tel. 035/4232911 - Fax. 035/4522445 CHINESE P. (BG) Tel. 035/850294 - Fax. 035/8583339		<b>AFS 404 600</b>	
TUTTE LE NORME RICHIAMATE SI INTENDONO NELLA LORO ULTIMA EDIZIONE.		26/11/2010	
SALDATURE IN ACCORDO CON - WPS 1 s 9		<b>ASSIEME RIDUTTORE</b>	
GRADO DI PRECISIONE PER QUOTE LINEARI, ANGOLARI, GEOMETRICHE NON TOLLERATE		110,85 kg	
LAV. MECCANICHE UNI EN 22768 - F H		(FOGLIO) NUMERO DISEGNO <b>1 / 1</b> <b>A12-00003</b>	
CARPENTERIA UNI EN 22768 - C K		1:2	

Il disegno è proprietà della TESMEC s.p.a. A termini di legge si vieta tassativamente la riproduzione e la divulgazione a terzi.

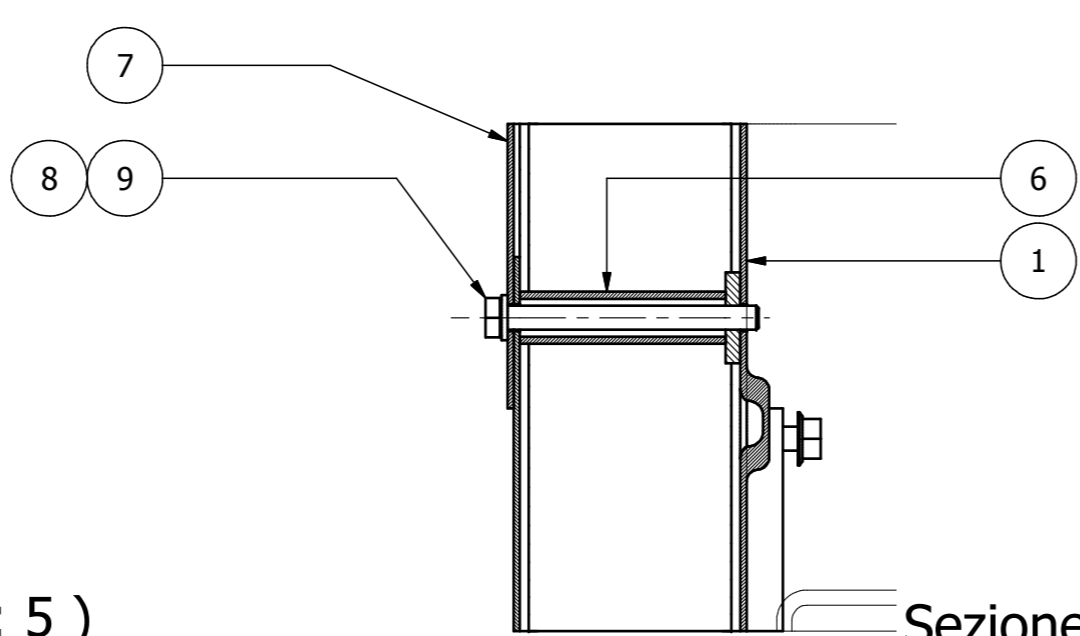
DATE	SYM	REVISION RECORD	DRCK



Sezione A-A ( 1 : 5 )



Sezione C-C ( 1 : 5 )



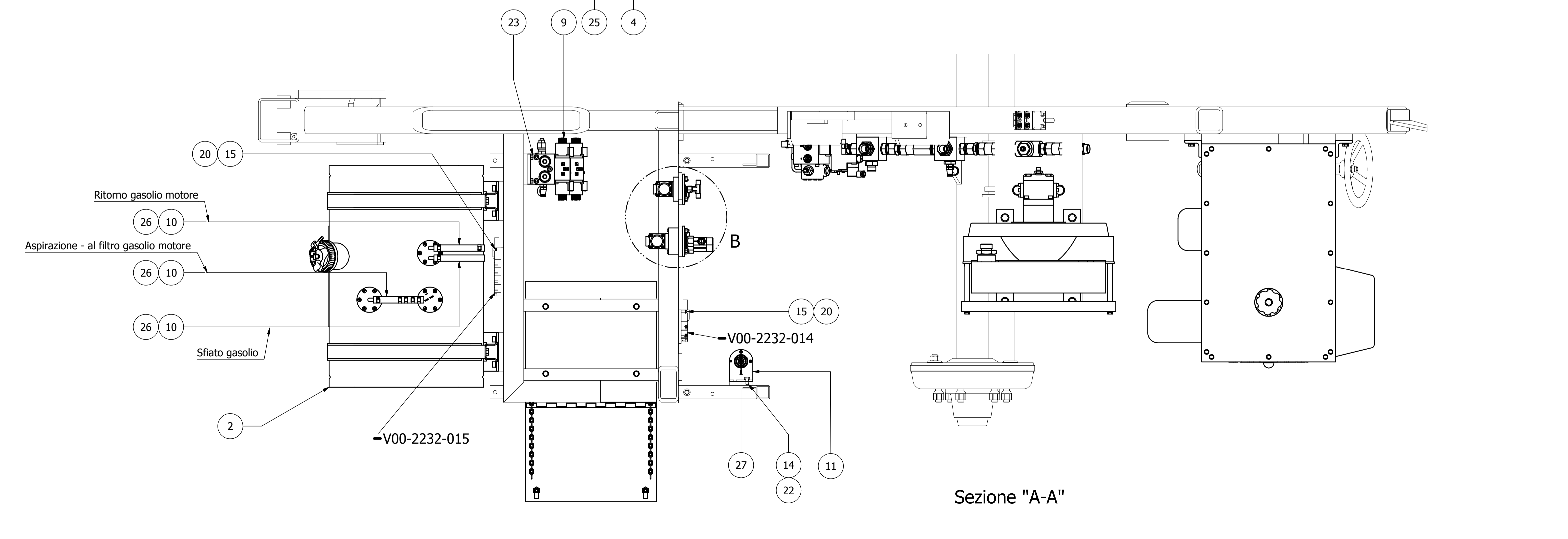
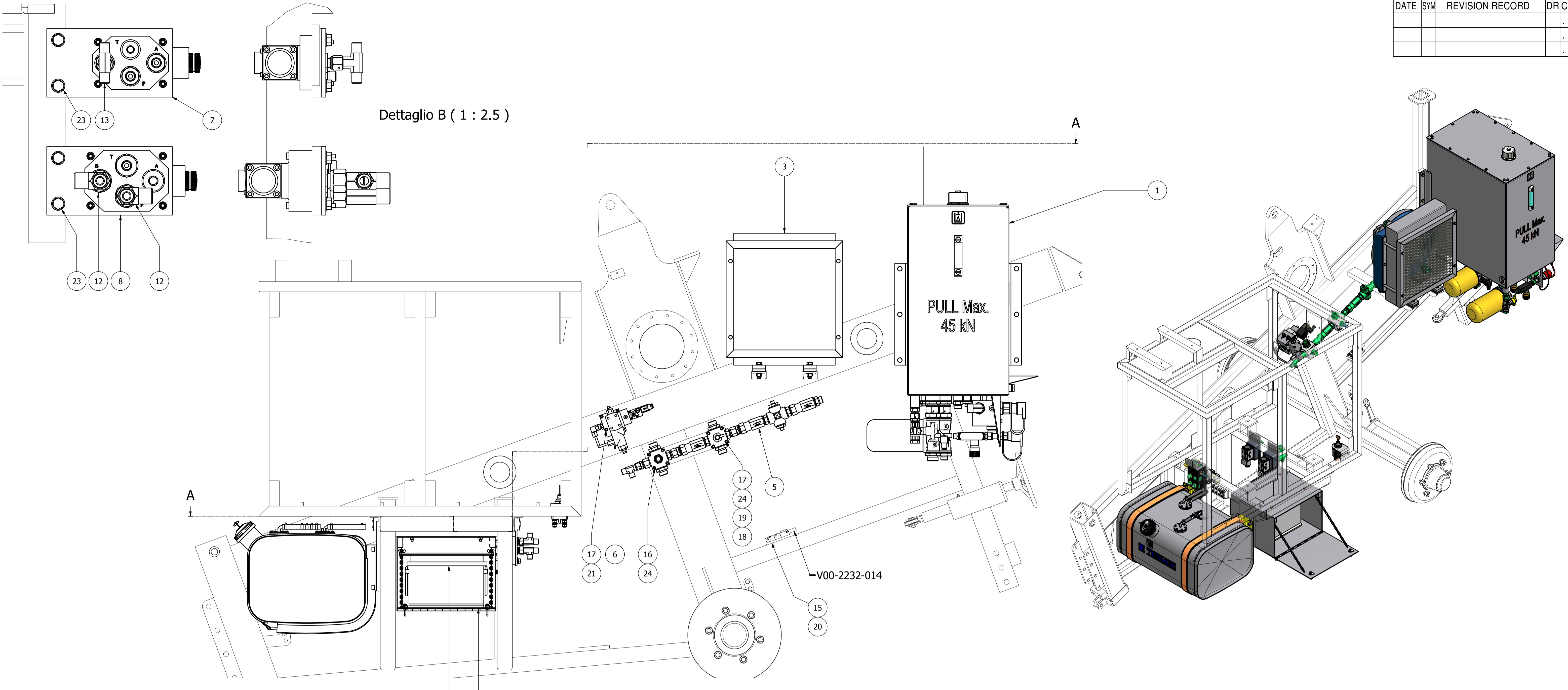
Sezione B-B ( 1 : 2.5 )

ITEM	CODE	DESCRIPTION	QTY	WEIGHT
16	D00-00309	TUBO D. 8 x 1 x lg. 400 [ ] PIPE	1	0.1 kg
15	H99-8900-002	VITE 0274 06 16 - M 6 x 16 - 8 - Z - WURTH [ ] BOLT	8	0 kg
14	V00-2231-059	TUBO CORRUGATO MULTI PA 6 ID70 NERO - D. 70 mm - FLEXA [ ] PIPE	0.8	1 kg
13	V00-2231-058	RACCORDO IN PLASTICA FLANGIATO - MULTI-GFP ID70 - FLEXA [ ] FITTING	2	0.1 kg
12	V00-5303-007	INGRASSATORE UNI 7663 - A - DIRITTO G 1/4" [ ] GREASE FITTING	1	0 kg
11	F11-0003-003	RONDELLA RAME D. 1/4" x 3 [ ] WASHER	1	0 kg
10	F99-0001-001	RACCORDO - 1/4" GAS M - TUBO D.8 mm - RASTELLI : TN 92 - 8 SR [ ] FITTING	1	0.1 kg
9	H53-1008-085	VITE - ISO 4014 - M 8 x 85 - 8.8 - Z - TE - PG - P.FIL [ ] BOLT	1	0 kg
8	H88-1008-002	ROSETTA-UNI 1751-A8-Z [ ] WASHER	1	0 kg
7	D00-00334	CARTER PROTEZIONE PIGNONE 75 x 440 x 1347 [ ] CASE	1	4.3 kg
6	D00-00569	DISTANZIALE D. 17.2 / 12.5 x LG. 68 - ZINCATO [ ] SPACER	1	0.1 kg
5	H50-1008-025	VITE-ISO 4017-M8x25-8.8-Z [ ] BOLT	4	0 kg
4	H77-1008-011	DADO - UNI 7473 - M 8 - GR. 8 - Z - AUTOB. [ ] LOCKNUT	4	0 kg
3	H81-1008-002	ROSETTA - ISO 7089 - TE - 8 - 100 HV - Z [ ] WASHER	8	0 kg
2	H99-8900-004	VITE 0274 08 16 - M 8 x 16 - 8 - Z - WURTH [ ] BOLT	53	0 kg
1	D00-00333	CARTER CORONE CABESTANI 77 x 1550 x 3170 [ ] CASE	1	98.1 kg

<b>TESMEC</b> GRASSORIBO (BG) Tel.035/4232911 - Fax 035/4522445 ENDINE G. (BG) Tel.035/825024 - Fax 035/826375		DIS. VISTO		ARGANO FRENO	
TUTTE LE NORME RICHIAMATE SI INTENDONO NELLA LORO ULTIMA EDIZIONE.		ghezzi		AFS 404 600	
SALDATURE IN ACCORDO CON - WPS 1-9		29/10/2009		ASSIEME COPERTURE	
GRADO DI PRECISIONE PER QUOTE LINEARI, ANGOLARI, GEOMETRICHE NON TOLLERATE		104,63 kg		(FOGLIO) NUMERO DISEGNO	
LAV.MECCANICHE UNI EN 22768-f H		SCALA 1:10		1 / 1	
CARPENTERIA UNI EN 22768-c K				A13-00003	

Il disegno è proprietà della TESMEC s.p.a. A termini di legge si vieta tassativamente la riproduzione e la divulgazione a terzi.

DATE	SYM	REVISION RECORD	DR/CK

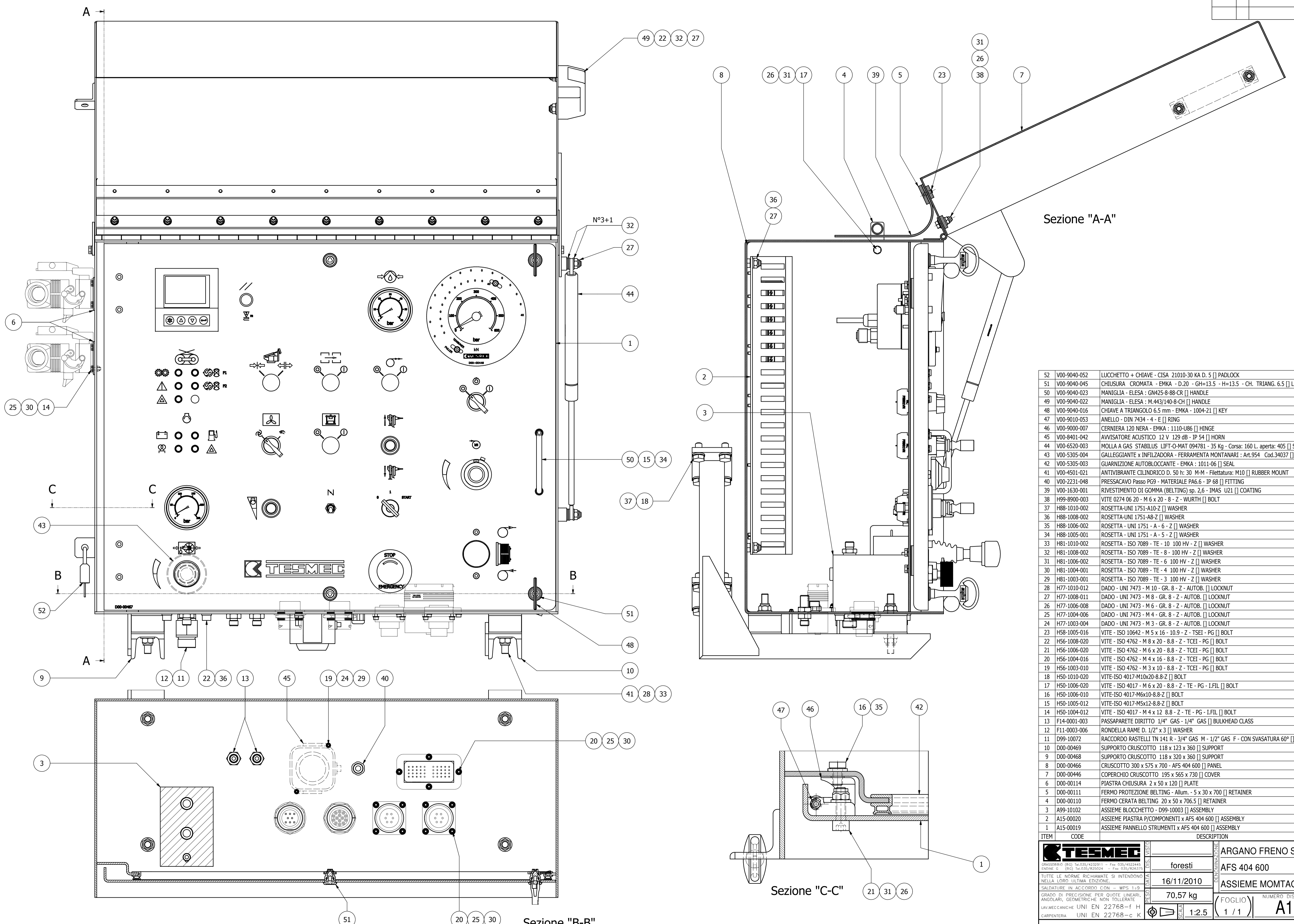


ITEM	CODE	DESCRIPTION	QTY	WEIGHT
27	V00-8401-038	INTERRUTTORE STACCABATTERIA 12-24 V - 250 A - IP 65 - COBO - 13.007.005 [ ] SWITCH	1	0.3 kg
26	V00-7050-014	FASCETTA SERRATUBO D. 16 / 25 - ABA : 92787 [ ] CLAMP	8	0 kg
25	V00-1500-003	BATTERIA 100 Ah 12 V - EN 760 A - B.325-L.175-H POLI 205-EXIDE:600/0 [ ] BATTERY	1	9.7 kg
24	H99-8900-046	ROSETTA - SCHNORR - D. 6 [ ] WASHER	4	0 kg
23	H99-8900-004	VITE 0274 08 16 - M 8 x 16 - 8 - Z - WURTH [ ] BOLT	6	0 kg
22	H88-1008-002	ROSETTA - UNI 1751 - A - 8 - Z [ ] WASHER	2	0 kg
21	H88-1006-002	ROSETTA - UNI 1751 - A - 6 - Z [ ] WASHER	3	0 kg
20	H88-1004-001	ROSETTA - UNI 1751 - A - 4 - Z [ ] WASHER	9	0 kg
19	H81-1006-002	ROSETTA - ISO 7089 - TE - 6 100 HV - Z [ ] WASHER	2	0 kg
18	H77-1006-008	DADO - UNI 7473 - M 6 - GR. 8 - Z - AUTOB. [ ] LOCKNUT	2	0 kg
17	H56-1006-090	VITE - ISO 4762 - M 6 x 90 - 8.8 - Z - TCEI - PG [ ] BOLT	5	0 kg
16	H56-1006-070	VITE - ISO 4762 - M 6 x 70 - 8.8 - Z - TCEI - PG [ ] BOLT	2	0 kg
15	H56-1004-020	VITE - M 4 x 20 - ISO 4762 - 8.8 - Z [ ] BOLT	9	0 kg
14	H50-1008-016	VITE - M 8 x 16 - ISO 4017 - 8.8 - Z [ ] BOLT	2	0 kg
13	F05-0019-003	RACCORDO A T - 1/4" GAS - M - F GIREVOLE - M [ ] FITTING	1	0.1 kg
12	F05-0018-006	RACCORDO A T - 1/2" GAS - M-M-F GIREVOLE [ ] FITTING	2	0.3 kg
11	D00-00129	SUPPORTO STACCABATTERIE 50 x 70 x 95 [ ] SUPPORT	1	0.1 kg
10	D00-00120	TUBO FLEX GASOLIO D. 19 / 10 x lg. 2000 [ ] FLEX TUBE	3	0.4 kg
9	A99-10092	ASSIEME BASE MULTIPLA CETOP 03 (3) - V00-6100-071 - V00-6100-051 [ ] ASSEMBLY	1	9.3 kg
8	A99-10090	ASSIEME PIASTRA - BA 302 - ELETTRIV. V00-6100-052 - PIASTRA D99-10027 [ ] ASSEMBLY	1	3.7 kg
7	A99-10088	ASSIEME PIASTRA - BA 202 - ELETTRIV. V00-6100-050 - PIASTRA D99-10033 [ ] ASSEMBLY	1	2.1 kg
6	A99-10006	ASSIEME BLOCCO REGOLAZIONE TIRO - CON VALVOLA HAVE PMVP4-43/12 [ ] ASSEMBLY	1	7 kg
5	A99-10002	ASSIEME BLOCCETTO IN - OUT RADIATORE OLIO [ ] ASSEMBLY	1	8.3 kg
4	A26-00003	ASSIEME CASSETTA 1 BATTERIA - Larg.390 - Prof.360 - Alt.283 [ ] ASSEMBLY	1	17.9 kg
3	A14-00046	ASSIEME RADIATORE OLIO x AFS 404 601 [ ] ASSEMBLY	1	33.9 kg
2	A14-00018	ASSIEME SERBATOIO CARBURANTE 95 L x AFS 404 600 [ ] ASSEMBLY	1	28.7 kg
1	A14-00016	ASSIEME SERBATOIO OLIO x AFS 404 600 [ ] ASSEMBLY	1	99.6 kg

<b>TESMEC</b>		ARGANO FRENO	
GRASSANO (BG) Tel. 035/4232911 - Fax 035/4522445 CINQUE C. (BG) Tel. 035/8520294 - Fax 035/8526339		Ghezzi B. AFS 404 601	
TUTTE LE NORME RICHIAMATE SI INTENDONO NELLA LORO ULTIMA EDIZIONE.		25/10/2011 ASSIEME MONTAGGIO ALIMENTAZIONE	
SALDATURE IN ACCORDO CON - WPS 1 s 9		222,60 kg (FOGLIO 1 / 1) NUMERO DISEGNO A14-00047	
GRADO DI PRECISIONE PER QUOTE LINEARI, ANGOLARI, GEOMETRICHE NON TOLLERATE		1:7.5	
LAVMECCANICHE UNI EN 22768-F H		1:7.5	
CARPENTERIA UNI EN 22768-C K		1:7.5	

Il disegno è proprietà della TESMEC s.p.a. A termini di legge si vieta tassativamente la riproduzione e la divulgazione a terzi.

DATE	SYM	REVISION RECORD	DRCK



Sezione "A-A"

Sezione "C-C"

Sezione "B-B"

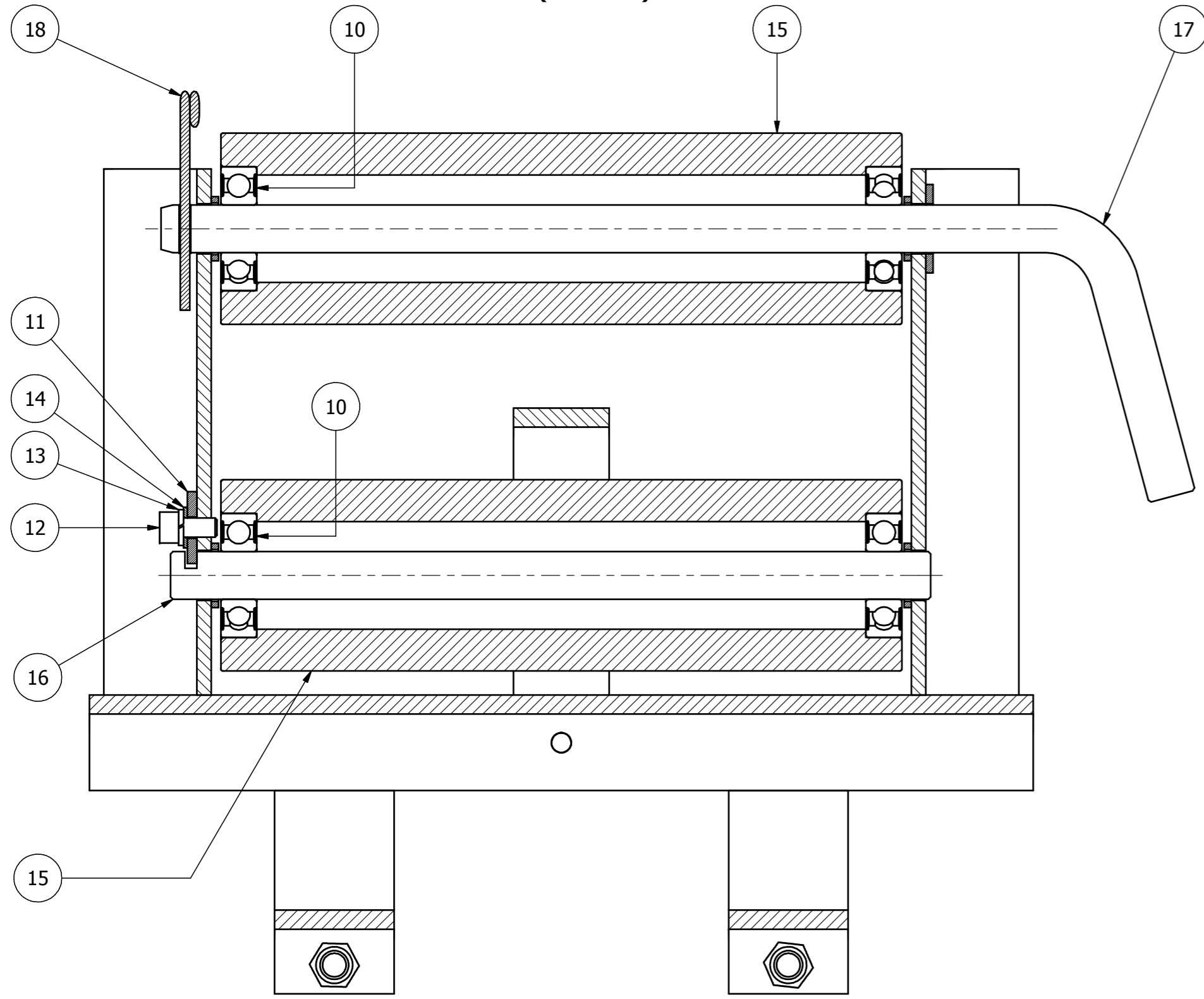
52	V00-9040-052	LUCCHETTO + CHIAVE - CISA 21010-30 KA D. 5 [ ] PADLOCK	1	0.1 kg
51	V00-9040-045	CHIUSURA CROMATA - EMKA - D.20 - GH=13.5 - H=13.5 - CH. TRIANG. 6.5 [ ] LOCKING	4	0 kg
50	V00-9040-023	MANIGLIA - ELESA - GN425-8-88-CR [ ] HANDLE	1	0.1 kg
49	V00-9040-022	MANIGLIA - ELESA - M.443/140-8-CH [ ] HANDLE	1	0 kg
48	V00-9040-016	CHIAVE A TRIANGOLO 6.5 mm - EMKA - 1004-21 [ ] KEY	2	0 kg
47	V00-9010-053	ANELLO - DIN 7434 - 4 - E [ ] RING	2	0 kg
46	V00-9000-007	CERNIERA 120 NERA - EMKA : 1110-U86 [ ] HINGE	2	0.1 kg
45	V00-8401-042	AVVISATORE ACUSTICO 12 V 129 dB - IP 54 [ ] HORN	1	0.2 kg
44	V00-6520-003	MOLLA A GAS STABILUS LIFT-O-MAT 094781 - 35 Kg - Corsa: 160 L. aperta: 405 [ ] SPRING	1	0.1 kg
43	V00-5305-004	GALLEGGIANTE x INFILZADORA - FERRAMENTA MONTANARI : Art.954 Cod.34037 [ ] FLOAT	1	0 kg
42	V00-5305-003	GUARNIZIONE AUTOBLOCCANTE - EMKA : 1011-06 [ ] SEAL	2.3	0.2 kg
41	V00-4501-021	ANTIVIBRANTE CILINDRICO D. 50 h: 30 M-M - Filettatura: M10 [ ] RUBBER MOUNT	4	0.2 kg
40	V00-2231-048	PRESSACAVO Passo PG9 - MATERIALE PA6.6 - IP 68 [ ] FITTING	1	0 kg
39	V00-1630-001	RIVESTIMENTO DI GOMMA (BELTING) sp. 2,6 - IMAS U21 [ ] COATING	1	0.4 kg
38	H99-8900-003	VITE 0274 06 20 - M 6 x 20 - 8 - Z - WURTH [ ] BOLT	9	0 kg
37	H88-1010-002	ROSETTA-UNI 1751-A10-Z [ ] WASHER	8	0 kg
36	H88-1008-002	ROSETTA-UNI 1751-A8-Z [ ] WASHER	8	0 kg
35	H88-1006-002	ROSETTA - UNI 1751 - A - 6 - Z [ ] WASHER	4	0 kg
34	H88-1005-001	ROSETTA - UNI 1751 - A - 5 - Z [ ] WASHER	2	0 kg
33	H81-1010-002	ROSETTA - ISO 7089 - TE - 10 100 HV - Z [ ] WASHER	8	0 kg
32	H81-1008-002	ROSETTA - ISO 7089 - TE - 8 100 HV - Z [ ] WASHER	10	0 kg
31	H81-1006-002	ROSETTA - ISO 7089 - TE - 6 100 HV - Z [ ] WASHER	17	0 kg
30	H81-1004-001	ROSETTA - ISO 7089 - TE - 4 100 HV - Z [ ] WASHER	40	0 kg
29	H81-1003-001	ROSETTA - ISO 7089 - TE - 3 100 HV - Z [ ] WASHER	2	0 kg
28	H77-1010-012	DADO - UNI 7473 - M 10 - GR. 8 - Z - AUTOB. [ ] LOCKNUT	8	0 kg
27	H77-1008-011	DADO - UNI 7473 - M 8 - GR. 8 - Z - AUTOB. [ ] LOCKNUT	8	0 kg
26	H77-1006-008	DADO - UNI 7473 - M 6 - GR. 8 - Z - AUTOB. [ ] LOCKNUT	15	0 kg
25	H77-1004-006	DADO - UNI 7473 - M 4 - GR. 8 - Z - AUTOB. [ ] LOCKNUT	20	0 kg
24	H77-1003-004	DADO - UNI 7473 - M 3 - GR. 8 - Z - AUTOB. [ ] LOCKNUT	2	0 kg
23	H58-1005-016	VITE - ISO 10642 - M 5 x 16 - 10.9 - Z - TSEI - PG [ ] BOLT	9	0 kg
22	H56-1008-020	VITE - ISO 4762 - M 8 x 20 - 8.8 - Z - TCEI - PG [ ] BOLT	6	0 kg
21	H56-1006-020	VITE - ISO 4762 - M 6 x 20 - 8.8 - Z - TCEI - PG [ ] BOLT	4	0 kg
20	H56-1004-016	VITE - ISO 4762 - M 4 x 16 - 8.8 - Z - TCEI - PG [ ] BOLT	12	0 kg
19	H56-1003-010	VITE - ISO 4762 - M 3 x 10 - 8.8 - Z - TCEI - PG [ ] BOLT	2	0 kg
18	H50-1010-020	VITE-ISO 4017-M10x20-8.8-Z [ ] BOLT	8	0 kg
17	H50-1006-020	VITE - ISO 4017 - M 6 x 20 - 8.8 - Z - TE - PG - I.FIL [ ] BOLT	2	0 kg
16	H50-1006-010	VITE-ISO 4017-M6x10-8.8-Z [ ] BOLT	4	0 kg
15	H50-1005-012	VITE-ISO 4017-M5x12-8.8-Z [ ] BOLT	2	0 kg
14	H50-1004-012	VITE - ISO 4017 - M 4 x 12 8.8 - Z - TE - PG - I.FIL [ ] BOLT	8	0 kg
13	F14-0001-003	PASSAPARETE DIRITTO 1/4" GAS - 1/4" GAS [ ] BULKHEAD CLASS	2	0 kg
12	F11-0003-006	RONDELLA RAME D. 1/2" x 3 [ ] WASHER	1	0 kg
11	D99-10072	RACCORDO RASTELLI TN 141 R - 3/4" GAS M - 1/2" GAS F - CON SVASATURA 60° [ ] FITTING	1	0.2 kg
10	D00-00469	SUPPORTO CRUSCOTTO 118 x 123 x 360 [ ] SUPPORT	1	2.7 kg
9	D00-00468	SUPPORTO CRUSCOTTO 118 x 320 x 360 [ ] SUPPORT	1	4 kg
8	D00-00466	CRUSCOTTO 300 x 575 x 700 - AFS 404 600 [ ] PANEL	1	29.1 kg
7	D00-00446	COPERCHIO CRUSCOTTO 195 x 565 x 730 [ ] COVER	1	11.4 kg
6	D00-00114	PIASTRA CHIUSURA 2 x 50 x 120 [ ] PLATE	2	0.1 kg
5	D00-00111	FERMO PROTEZIONE BELTING - Allum. - 5 x 30 x 700 [ ] RETAINER	1	0.3 kg
4	D00-00110	FERMO CERATA BELTING 20 x 50 x 706.5 [ ] RETAINER	1	0.5 kg
3	A99-10102	ASSEMBIE BLOCCETTO - D99-10003 [ ] ASSEMBLY	1	2.8 kg
2	A15-00020	ASSEMBIE PIASTRA P/COMPONENTI x AFS 404 600 [ ] ASSEMBLY	1	7.9 kg
1	A15-00019	ASSEMBIE PANNELLO STRUMENTI x AFS 404 600 [ ] ASSEMBLY	1	8.4 kg
ITEM	CODE	DESCRIPTION	QTY	WEIGHT

<b>TESMEC</b>		ARGANO FRENO SINGOLO	
GRASSOBBIO (BG) Tel. 035/4232911 - Fax 035/4522445 CHIVRE' (BG) Tel. 035/8520294 - Fax 035/8528379		AFS 404 600	
TUTTE LE NORME RICHIAMATE SI INTENDONO NELLA LORO ULTIMA EDIZIONE.		ASSIEME MONTAGGIO CRUSCOTTO	
SALDATURE IN ACCORDO CON - WPS 1 s 9		FOGLIO 1 / 1	
GRADO DI PRECISIONE PER QUOTE LINEARI, ANGOLARI, GEOMETRICHE NON TOLLERATE		NUMERO DISEGNO A15-00018	
LAVMECCANICHE UNI EN 22768-f H		1:2.5	
CARPENTERIA UNI EN 22768-c K			

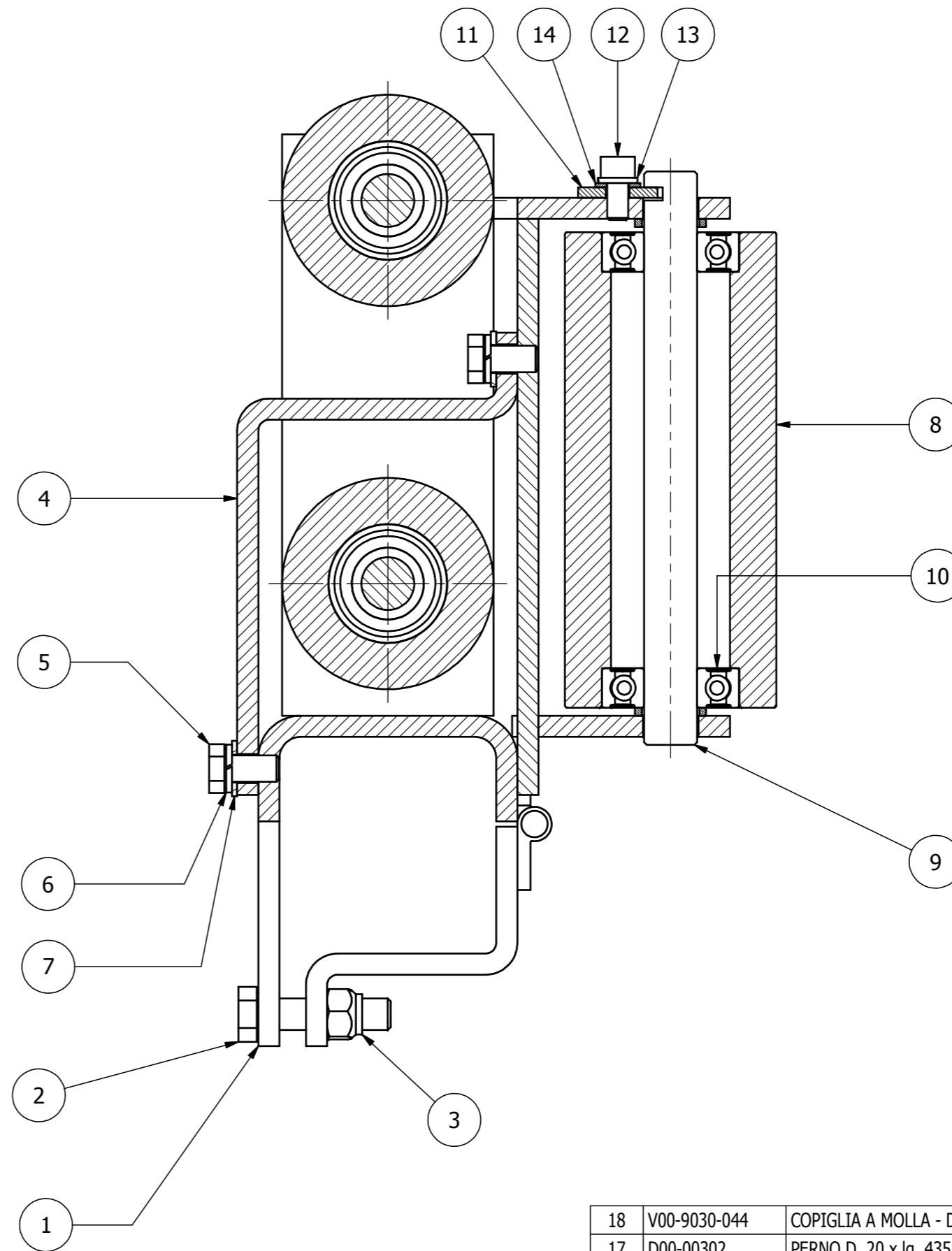
Il disegno è proprietà della TESMEC s.p.a. A termini di legge si vieta tassativamente la riproduzione e la divulgazione a terzi.

DATE	SYM	REVISION RECORD	DR/CK

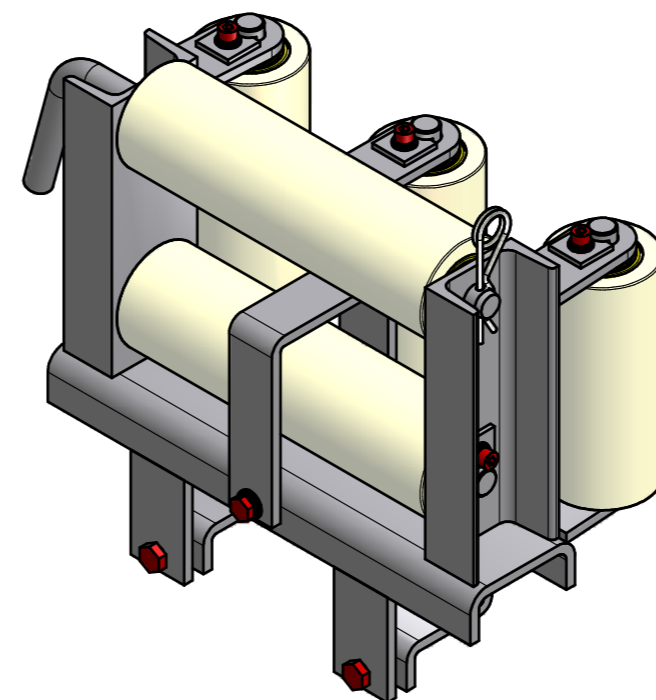
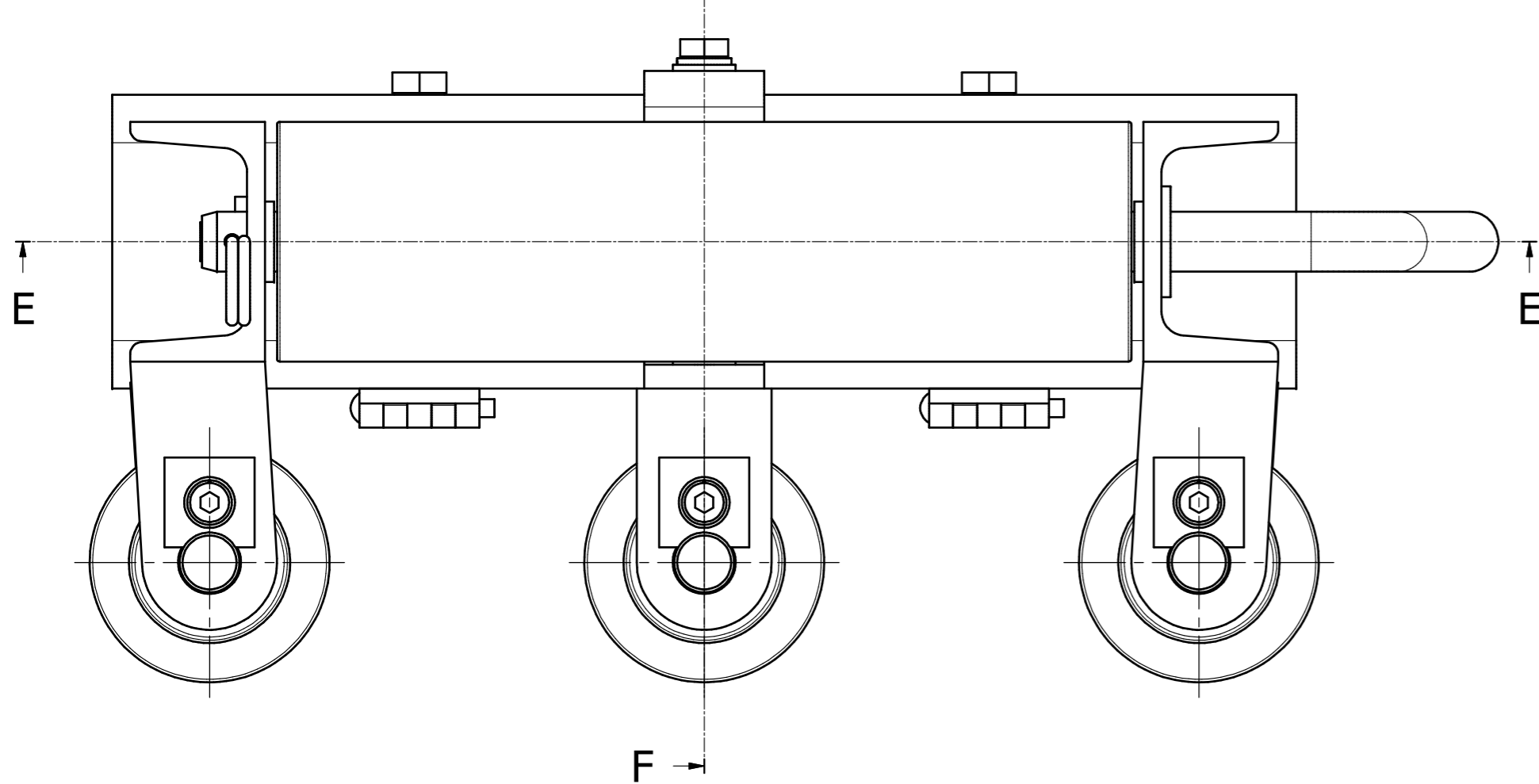
E-E (1:2)



F-F (1:2)



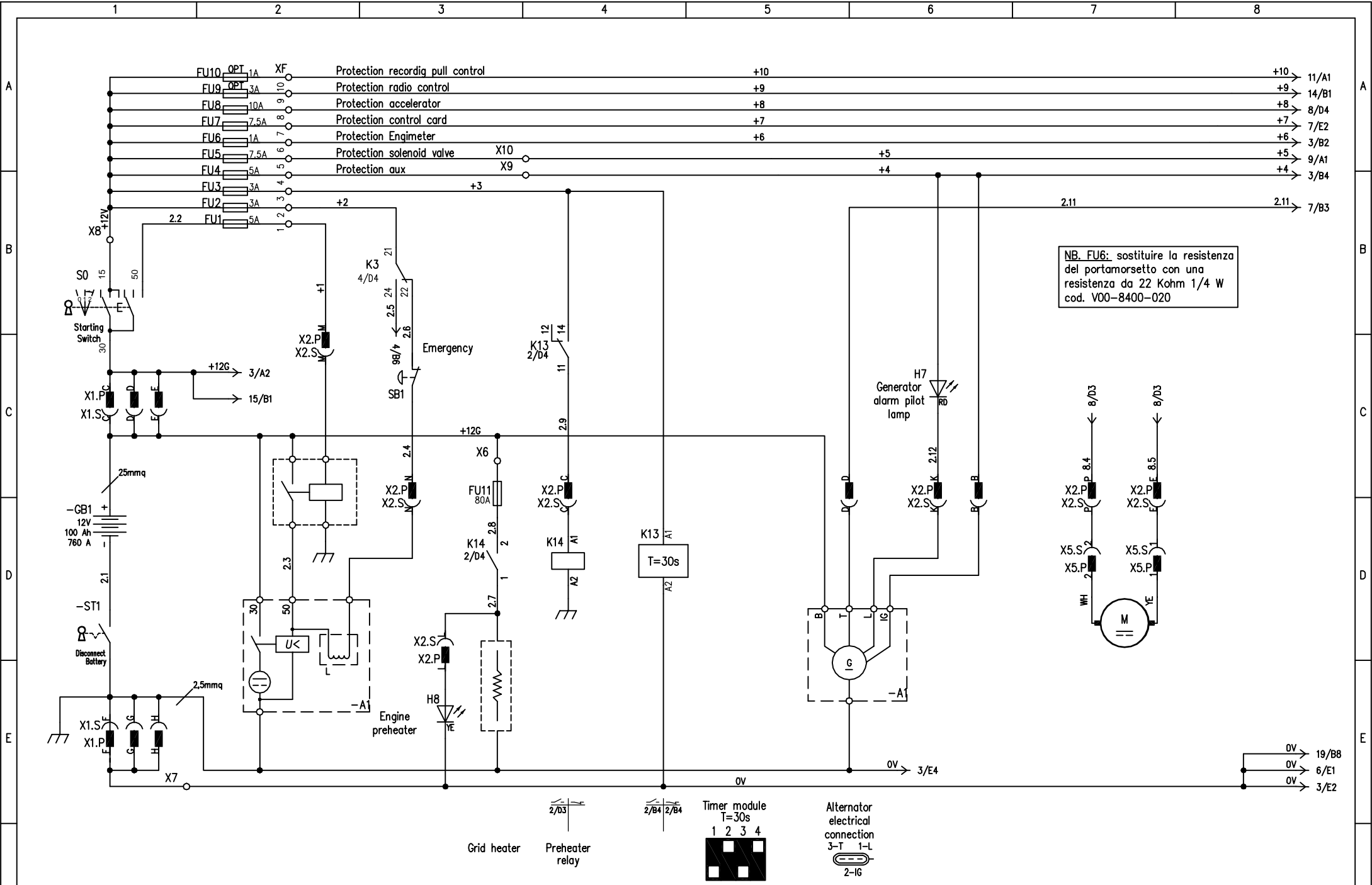
F



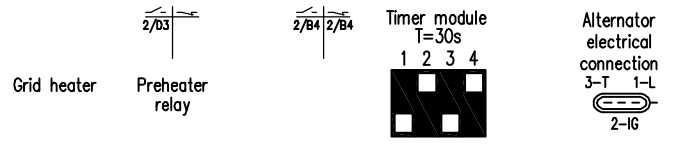
18	V00-9030-044	COPIGLIA A MOLLA - DOPPIO GIRO D. 4 - AMA : ART. 469 [ ] COTTER PIN	1	0 kg
17	D00-00302	PERNO D. 20 x lg. 435 - A MANIGLIA [ ] PIN	1	1.3 kg
16	D00-00301	PERNO D. 20 x lg. 318 - ZINCATO - SEDE PIASTRINA [ ] PIN	1	0.8 kg
15	D00-00303	RULLO D. 80 / 45 x lg. 285 [ ] ROLLER	2	1.1 kg
14	H81-1008-002	ROSETTA - ISO 7089 - TE - 8 - 100 HV - Z [ ] WASHER	4	0 kg
13	H88-1008-002	ROSETTA-UNI 1751-A8-Z [ ] WASHER	4	0 kg
12	H56-1008-016	VITE - ISO 4762 - M 8 x 16 - 8.8 - Z - TCEI - PG [ ] BOLT	4	0 kg
11	D00-00071	PIASTRA - S 235 JR - 4 x 30 x 30 [ ] PLATE	4	0 kg
10	V00-5100-010	CUSCINETTO 6304-RSH - RADIALE A SFERE - d 20 / D 52 x B 15 [ ] BEARING	10	0.1 kg
9	D00-00537	PERNO D. 20 x lg. 217 - ZINCATO - SEDE PIASTRINA [ ] PIN	3	0.5 kg
8	D00-00072	RULLO D. 80 / 45 x lg. 180 [ ] ROLLER	3	0.7 kg
7	H81-1010-002	ROSETTA - ISO 7089 - TE - 10 100 HV - Z [ ] WASHER	2	0 kg
6	H88-1010-002	ROSETTA-UNI 1751-A10-Z [ ] WASHER	2	0 kg
5	H50-1010-020	VITE-ISO 4017-M10x20-8.8-Z [ ] BOLT	2	0 kg
4	D00-00304	STAFFA RULLIERA 40 x 106 x 175 [ ] MOUNTING	1	0.7 kg
3	H77-1012-015	DADO - UNI 7473 - M 12 - GR. 8 - Z - AUTOB. [ ] LOCKNUT	2	0 kg
2	H50-1012-050	VITE - ISO 4017 - M 12 x 50 - 8.8 - Z - TE - PG - I.FIL [ ] BOLT	2	0.1 kg
1	D00-00300	SUPPORTO RULLI 180 x 345 x 395 [ ] SUPPORT	1	11 kg

ITEM	CODE	DESCRIPTION	QTY	WEIGHT
		Ing. Oscar	ARGANI FRENI - FRENI	
<small>GRASSORIBO (BG) Tel.035/4232911 - Fax 035/4522445 ENDINE G. (BG) Tel.035/825024 - Fax 035/826375</small>		ghezzi	VARI	
<small>TUTTE LE NORME RICHIAMATE SI INTENDONO NELLA LORO ULTIMA EDIZIONE.</small>		31/08/2009	ASSIEME MONTAGGIO RULLIERA	
<small>SALDATURE IN ACCORDO CON - WPS 1-9</small>		21,32 kg	<small>NUMERO DISEGNO</small> <b>A17-00003</b>	
<small>GRADO DI PRECISIONE PER QUOTE LINEARI, ANGOLARI, GEOMETRICHE NON TOLLERATE</small>		1:2	<small>FOGLIO</small> 1 / 1	
<small>LAV.MECCANICHE UNI EN 22768-f H CARPENTERIA UNI EN 22768-c K</small>		<small>Il disegno è proprietà della TESMEC s.p.a. A termini di legge si vieta tassativamente la riproduzione e la divulgazione a terzi.</small>		





NB. FU6: sostituire la resistenza del portamorsetto con una resistenza da 22 Kohm 1/4 W cod. V00-8400-020



The design and drawings are property of Tesmec SpA, copying and unauthorized disclosure are forbidden.

Electric scheme

ENGINE INTERFACE

Drawn: Patani

Drawing Nr. S01-00010  
Archive Nr. S01

Sheet 2 of 38

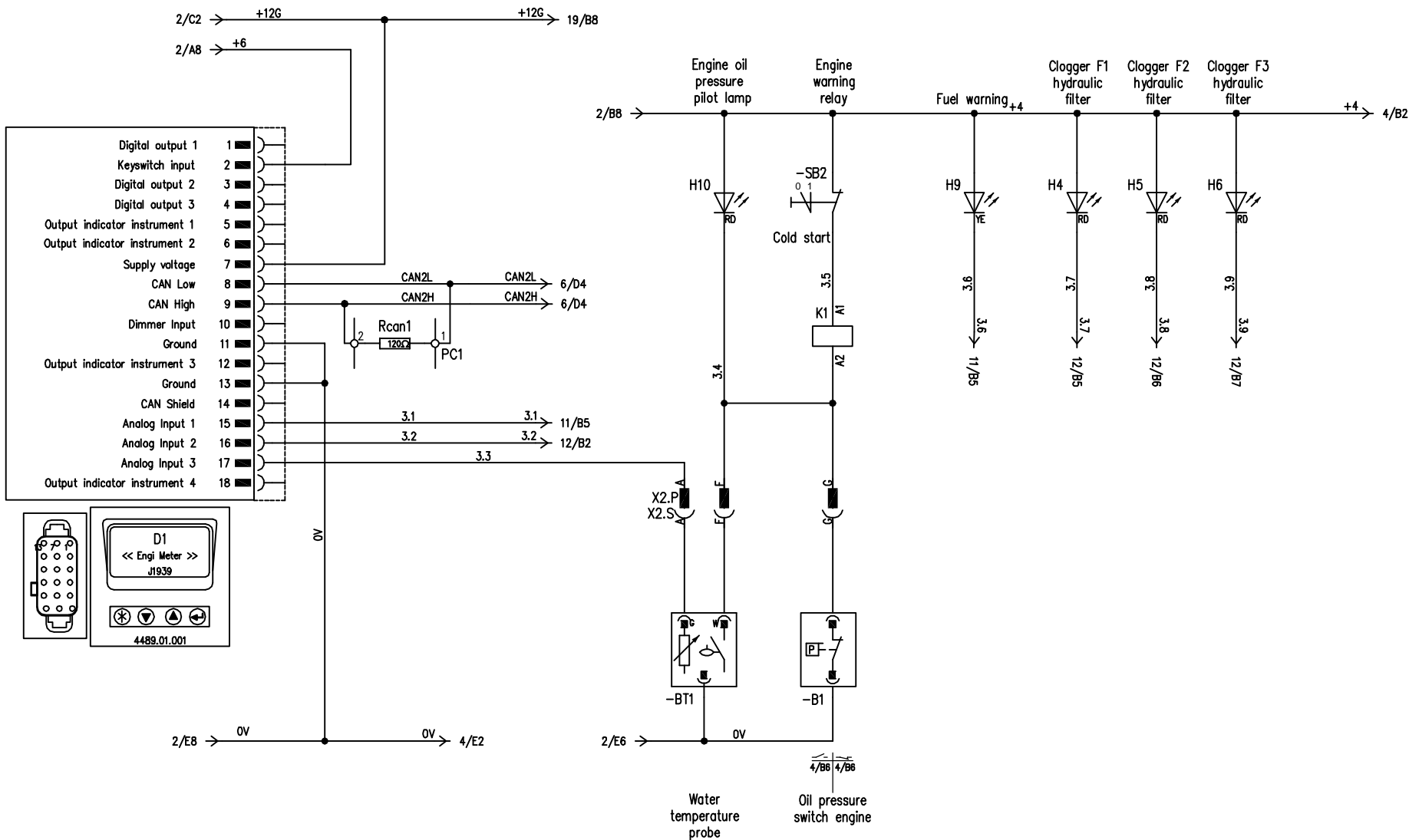
Grassobio BG via Zanica, 17/a - Italy - Email: info@tesmec.it tel: +39 035 4232911 fax: +39 035 4522445  
Sede di Endine Gaiano BG via Pertegalli - Italy - tel: +39 035 825024 fax: +39 035 826375

Design : AFS 404 600

Checked : Ing. Oscar

Date: 11/01/2011

Following 3



The design and drawings are property of Tesmec SpA, copying and unauthorized disclosure are forbidden

Electric scheme

ENGINE INTERFACE

Drawn: Patani

Drawing Nr. S01-00010  
Archive Nr. S01

Sheet 3 of 38

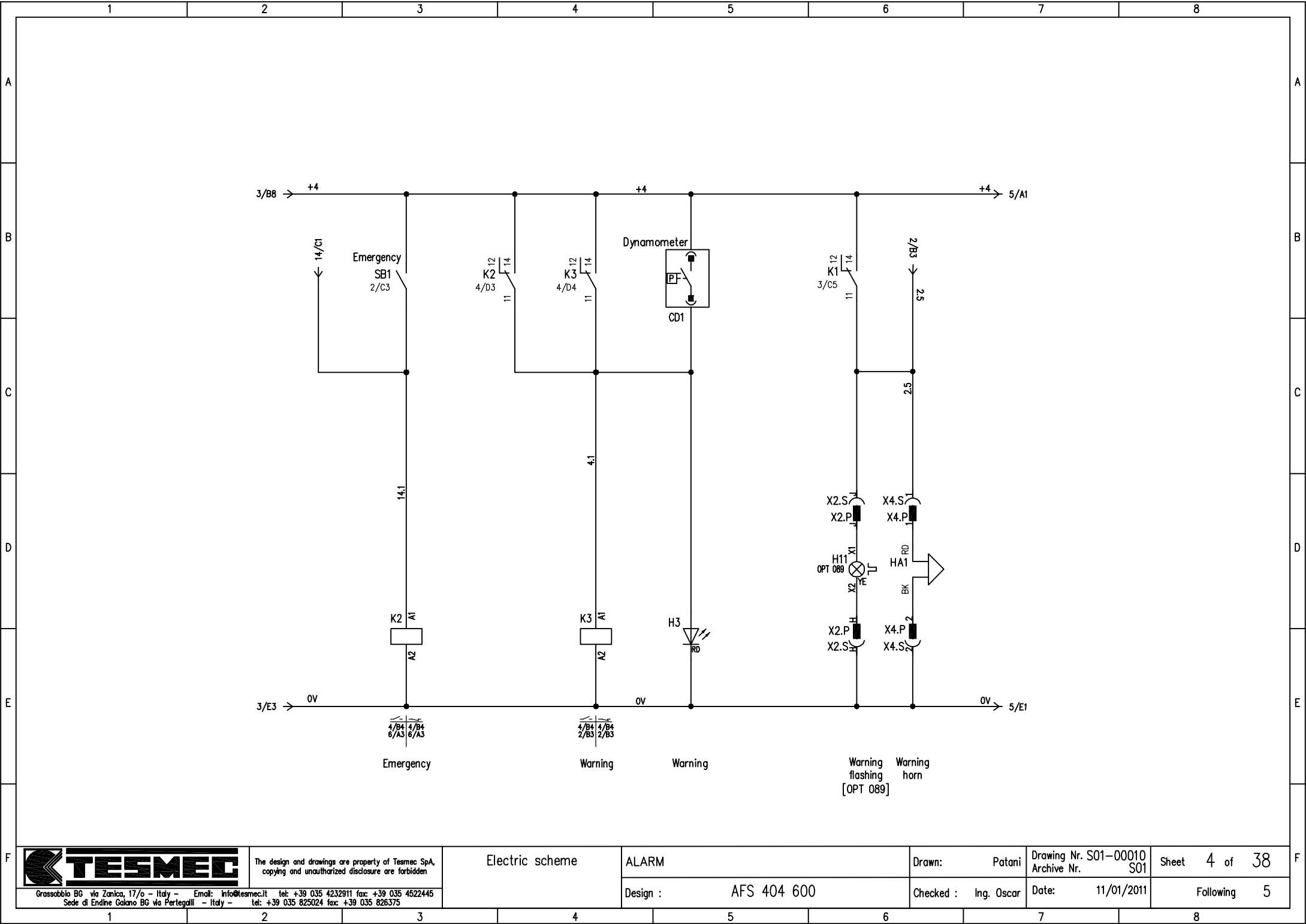
Grassobbio BG via Zanica, 17/a - Italy - Email: info@tesmec.it tel: +39 035 4232911 fax: +39 035 4522445  
Sede di Endine Galano BG via Pertegalli - Italy - tel: +39 035 825024 fax: +39 035 826375

Design : AFS 404 600

Checked : Ing. Oscar

Date: 11/01/2011

Following 4



The design and drawings are property of Tesmec SpA, copying and unauthorized disclosure are forbidden

Electric scheme

ALARM

Drawn: Patani

Drawing Nr. S01-00010  
Archive Nr. S01

Sheet 4 of 38

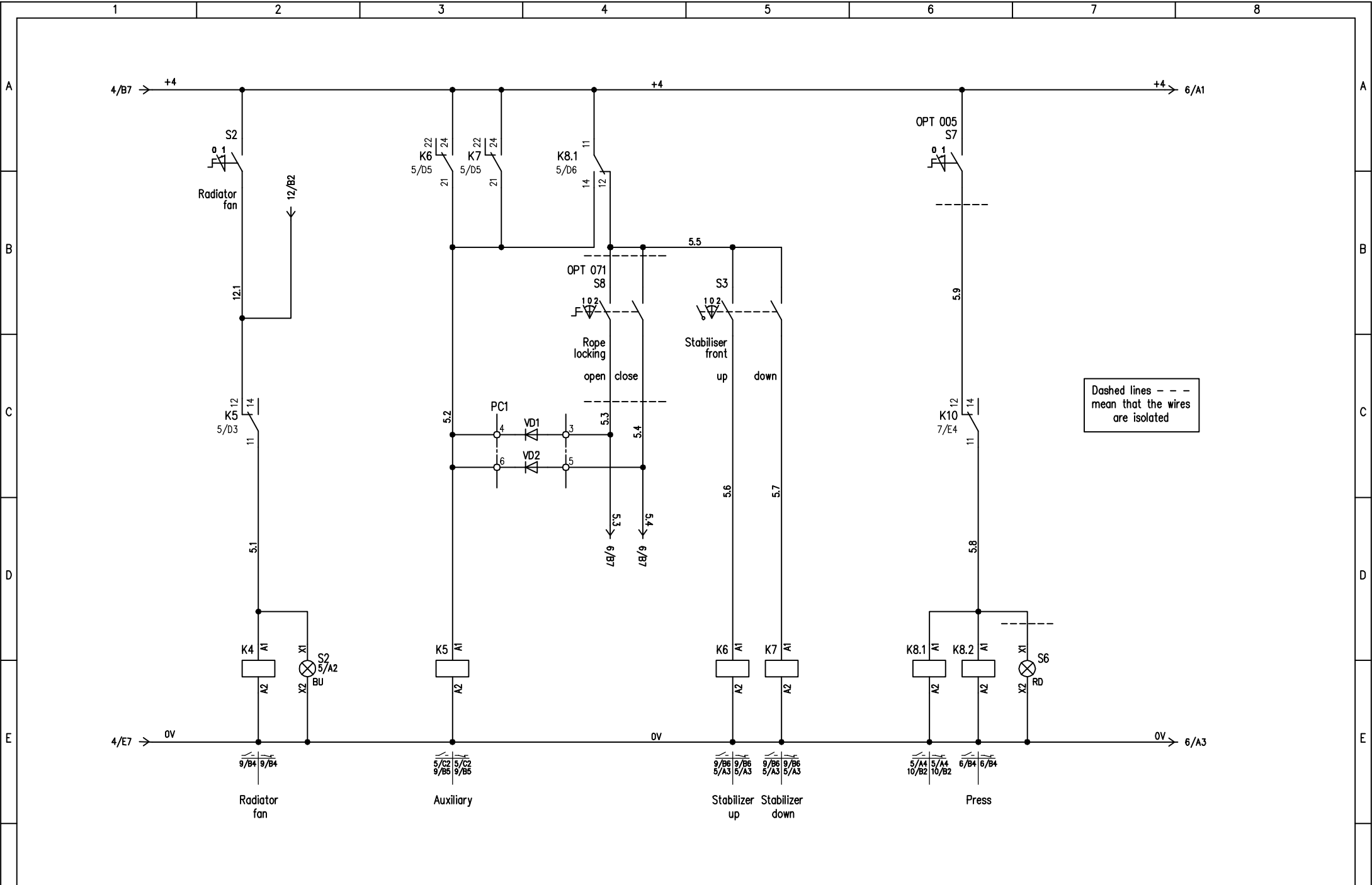
Grassobbio BG via Zanica, 17/a - Italy - Email: info@tesmec.it tel: +39 035 4232911 fax: +39 035 4522445  
Sede di Endine Gaiano BG via Pertegalli - Italy - tel: +39 035 825024 fax: +39 035 826375

Design : AFS 404 600

Checked : Ing. Oscar

Date: 11/01/2011

Following 5



The design and drawings are property of Tesmec SpA, copying and unauthorized disclosure are forbidden

Electric scheme

AUXILIARY CONTROL

Drawn: Patani

Drawing Nr. S01-00010  
Archive Nr. S01

Sheet 5 of 38

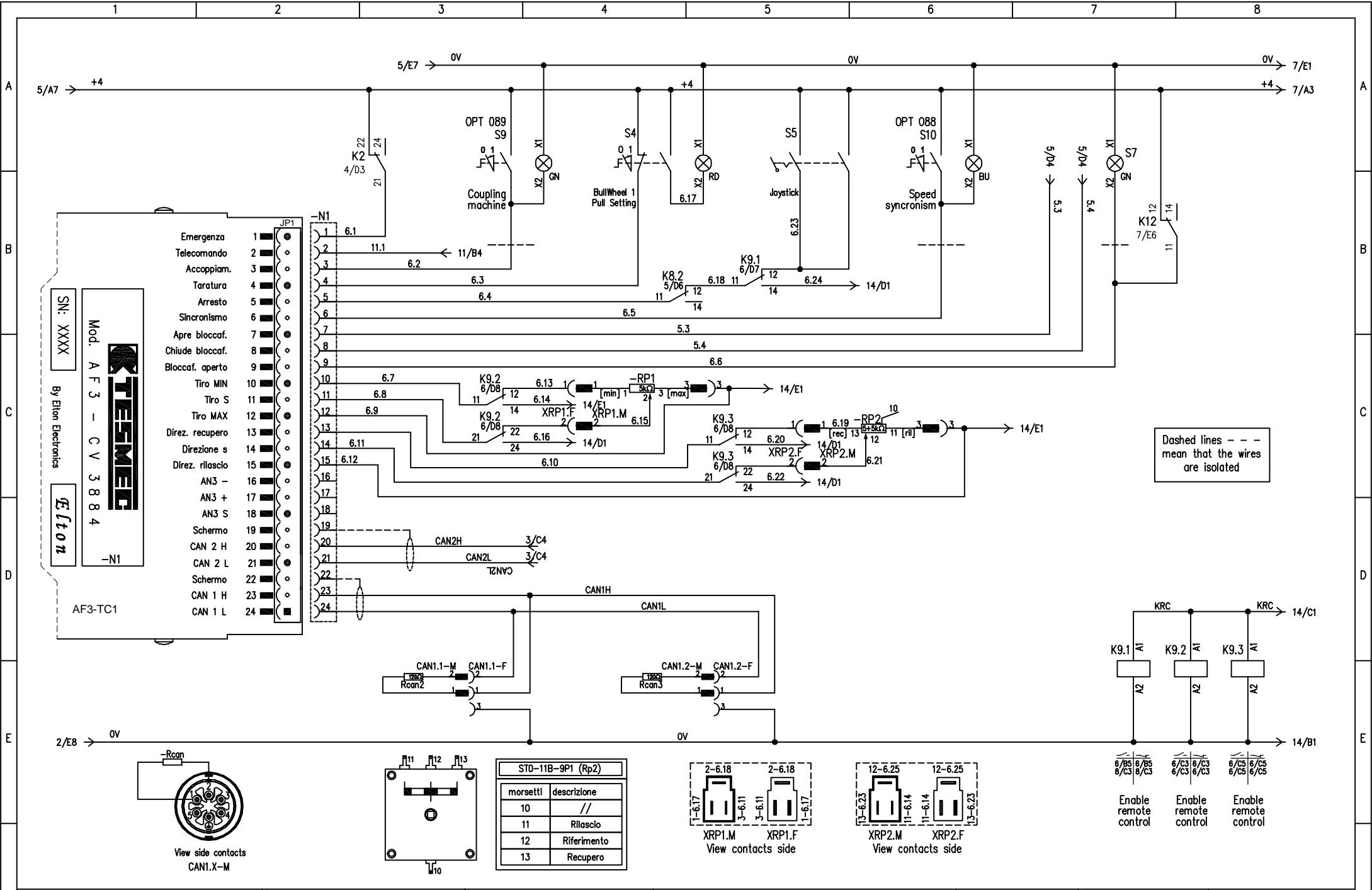
Grassobio BG via Zanica, 17/a - Italy - Email: info@tesmec.it tel: +39 035 4232911 fax: +39 035 4522445  
Sede di Endine Gaiano BG via Pertegalli - Italy - tel: +39 035 825024 fax: +39 035 826375

Design : AFS 404 600

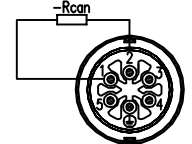
Checked : Ing. Oscar

Date: 11/01/2011

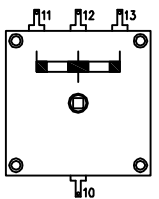
Following 6



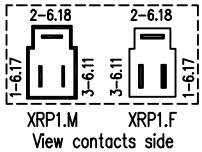
Dashed lines - - - mean that the wires are isolated



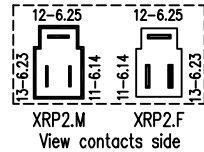
View side contacts CAN1.X-M



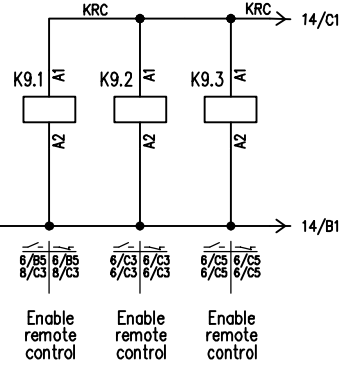
ST0-11B-9P1 (Rp2)	
morsetti	descrizione
10	//
11	Rilascio
12	Riferimento
13	Recupero



View contacts side



View contacts side



Enable remote control



The design and drawings are property of Tesmec SpA, copying and unauthorized disclosure are forbidden

Electric scheme

ELECTRONIC CONTROL 1: INPUT

Drawn: Patani

Drawing Nr. S01-00010  
Archive Nr. S01

Sheet 6 of 38

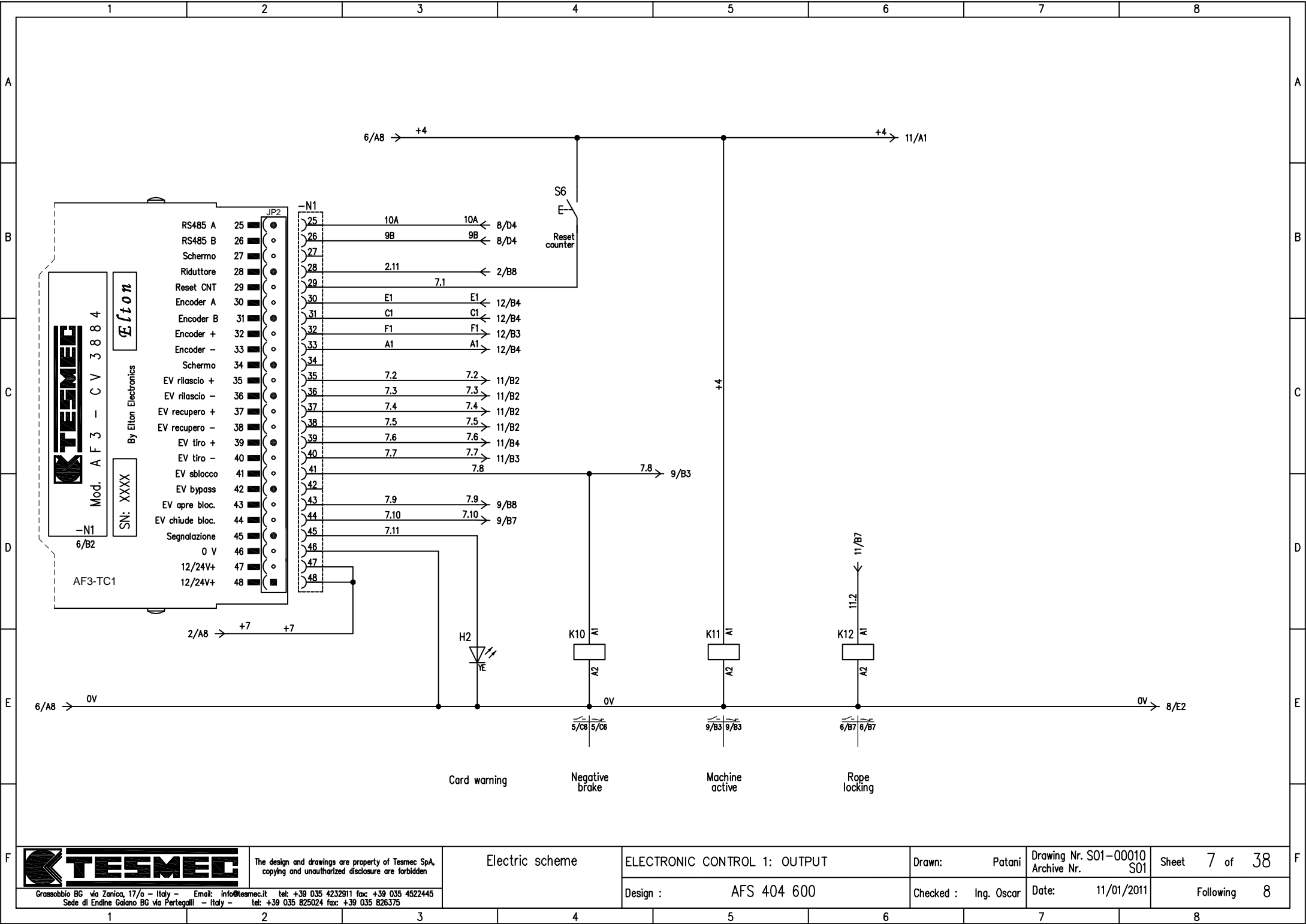
Grassobbio BG via Zanica, 17/a - Italy - Email: info@tesmec.it tel: +39 035 4232911 fax: +39 035 4522445  
Sede di Endine Galiano BG via Pertegalli - Italy - tel: +39 035 825024 fax: +39 035 826375

Design : AFS 404 600

Checked : Ing. Oscar

Date: 11/01/2011

Following 7



The design and drawings are property of Tesmec SpA, copying and unauthorized disclosure are forbidden

Electric scheme

ELECTRONIC CONTROL 1: OUTPUT

Drawn: Patani

Drawing Nr. S01-00010  
Archive Nr. S01

Sheet 7 of 38

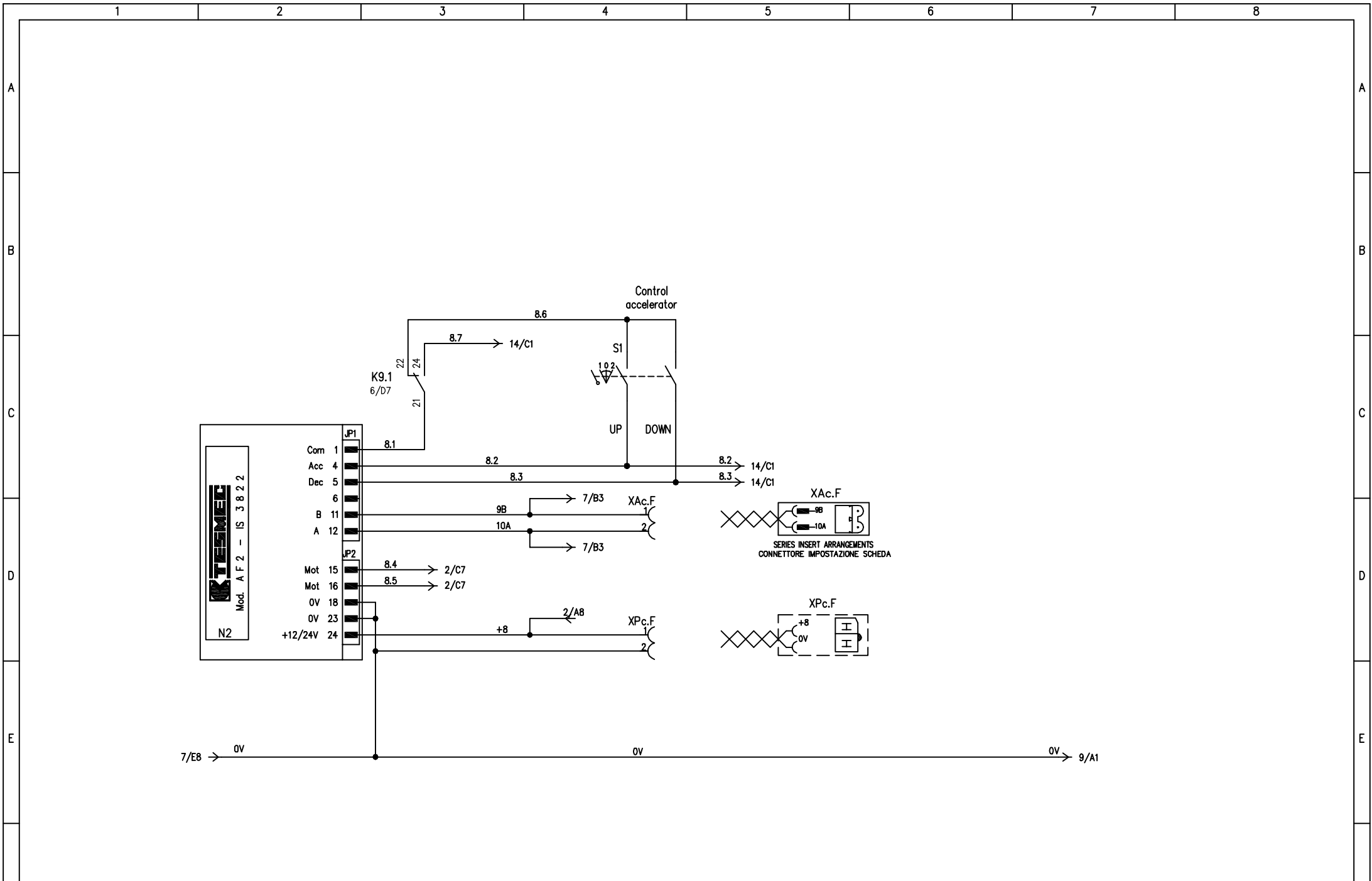
Grassobbio BG via Zanica, 17/a - Italy - Email: info@tesmec.it tel: +39 035 4232911 fax: +39 035 4522445  
Sede di Endine Galiano BG via Pertegalli - Italy - tel: +39 035 825024 fax: +39 035 826375

Design : AFS 404 600

Checked : Ing. Oscar

Date: 11/01/2011

Following 8



The design and drawings are property of Tesmec SpA, copying and unauthorized disclosure are forbidden

Electric scheme

ELECTRIC ACCELERATOR

Drawn: Patani

Drawing Nr. S01-00010  
Archive Nr. S01

Sheet 8 of 38

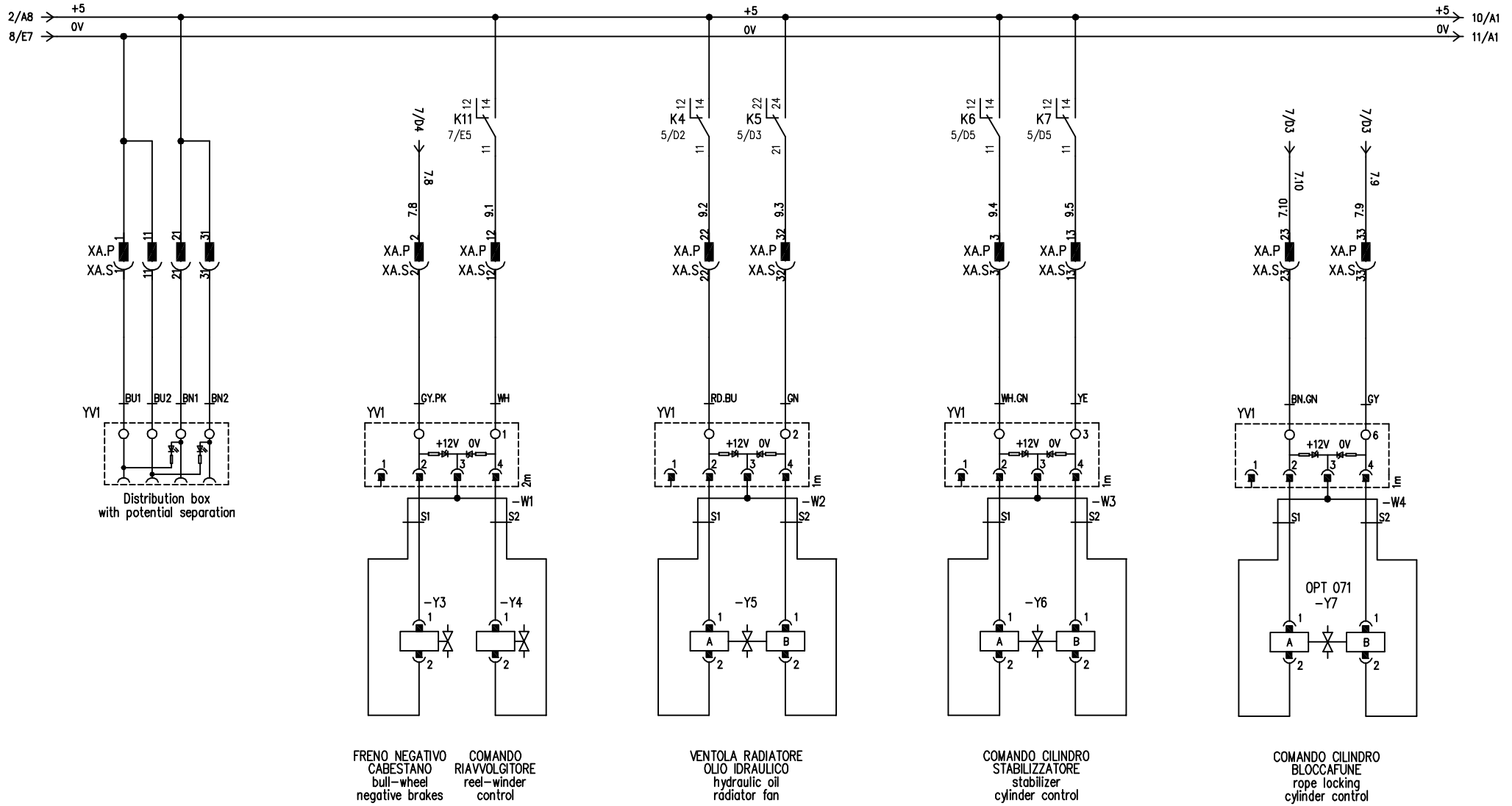
Grassobbio BG via Zanica, 17/a - Italy - Email: info@tesmec.it tel: +39 035 4232911 fax: +39 035 4522445  
Sede di Endine Galiano BG via Pertegalli - Italy - tel: +39 035 825024 fax: +39 035 826375

Design : AFS 404 600

Checked : Ing. Oscar

Date: 11/01/2011

Following 9



The design and drawings are property of Tesmec SpA, copying and unauthorized disclosure are forbidden

Electric scheme

SOCKET 1

Drawn: Patani

Drawing Nr. S01-00010  
Archive Nr. S01

Sheet 9 of 38

Grassobbio BG via Zanica, 17/a - Italy - Email: info@tesmec.it tel: +39 035 4232911 fax: +39 035 4522445  
Sede di Endine Galiano BG via Pertegalli - Italy - tel: +39 035 825024 fax: +39 035 826375

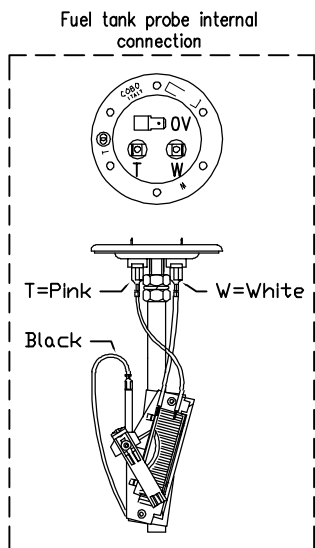
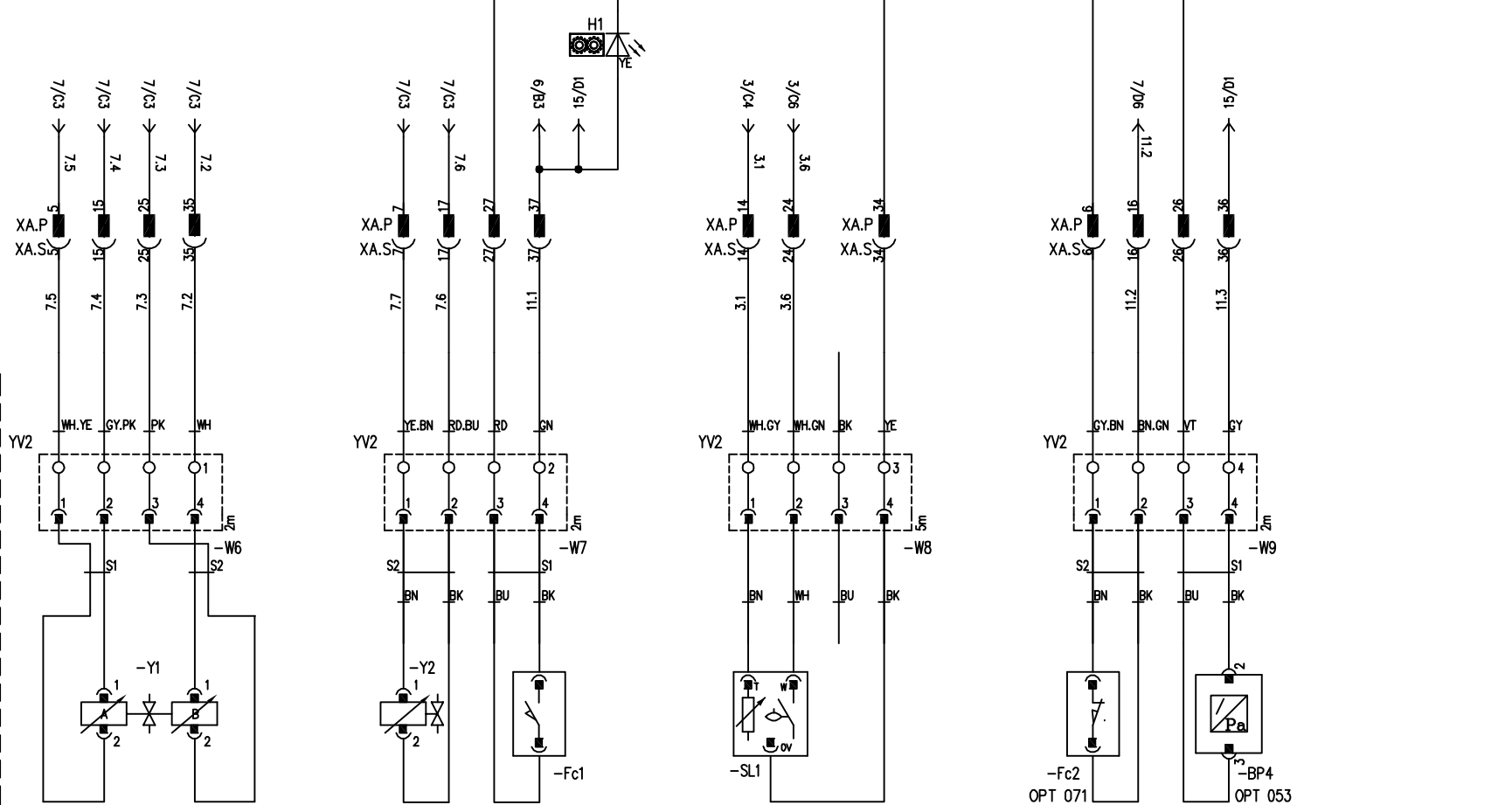
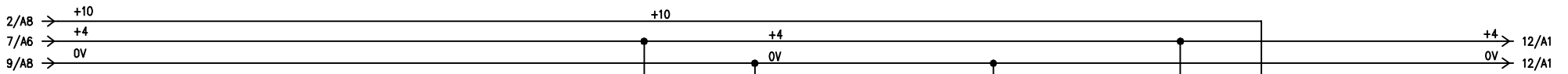
Design : AFS 404 600

Checked : Ing. Oscar

Date: 11/01/2011

Following 10





COMANDO  
POMPA  
pump  
control

REGOLAZIONE TIRO  
CABESTANO  
bull-wheel  
pull setting

FINECORSA  
RIDUTTORE  
position gearbox  
1 limit switch

SENSORE  
SERBATOIO CARBURANTE  
fuel tank  
probe

FINECORSA  
BLOCCAFUNE  
limit switch  
rope locking

TRASDUTTORE  
PRESSIONE  
pressure  
transducer



The design and drawings are property of Tesmec SpA, copying and unauthorized disclosure are forbidden

Electric scheme

SOCKET 2

Drawn: Patani

Drawing Nr. S01-00010  
Archive Nr. S01

Sheet 11 of 38

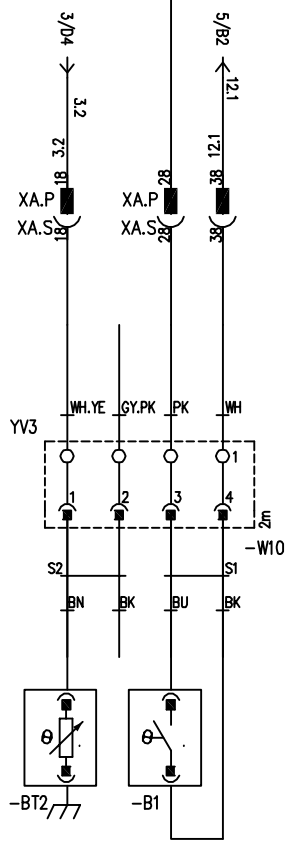
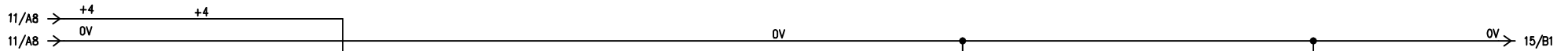
Grassobbio BG via Zanica, 17/a - Italy - Email: info@tesmec.it tel: +39 035 4232911 fax: +39 035 4522445  
Sede di Endine Galiano BG via Pertegalli - Italy - tel: +39 035 825024 fax: +39 035 826375

Design : AFS 404 600

Checked : Ing. Oscar

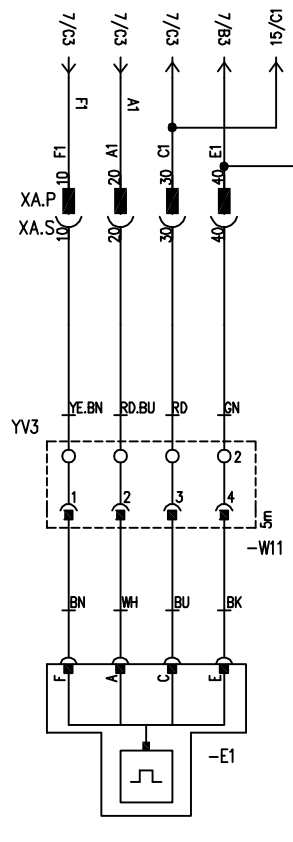
Date: 11/01/2011

Following 12

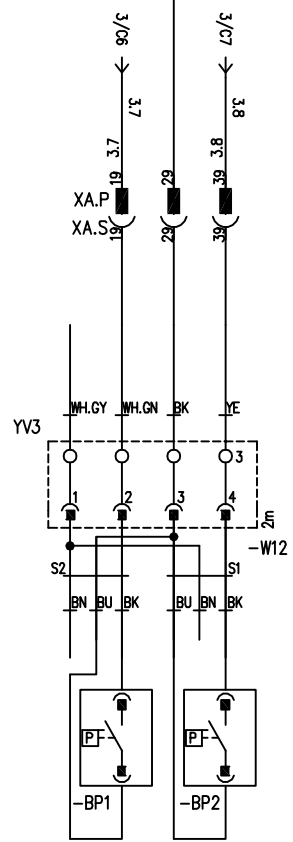


SENSORE TEMPERATURA  
OLIO IDRAULICO  
hydraulic oil  
temperature probe

TERMOSTATO  
OLIO IDRAULICO  
hydraulic oil  
temperature switch

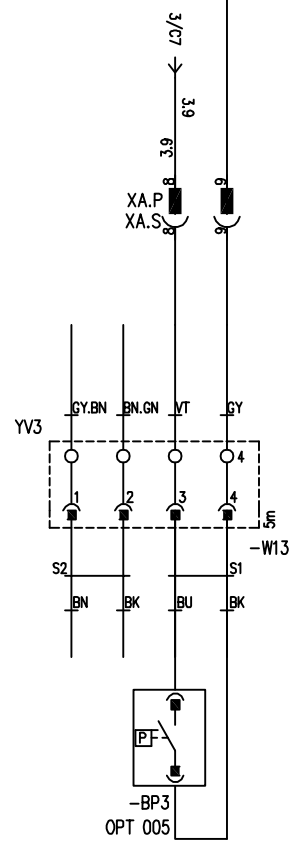


ENCODER



FILTRO IDRAULICO  
F1 INTASATO  
clogged F1  
hydraulic filter

FILTRO IDRAULICO  
F2 INTASATO  
clogged F2  
hydraulic filter



FILTRO IDRAULICO  
F3 INTASATO  
clogged F3  
hydraulic filter



The design and drawings are property of Tesmec SpA,  
copying and unauthorized disclosure are forbidden

Electric scheme

SOCKET 3

Drawn:

Patani

Drawing Nr. S01-00010  
Archive Nr. S01

Sheet 12 of 38

Grassobbio BG via Zanica, 17/a - Italy - Email: info@tesmec.it tel: +39 035 4232911 fax: +39 035 4522445  
Sede di Endine Galiano BG via Pertegalli - Italy - tel: +39 035 825024 fax: +39 035 826375

Design :

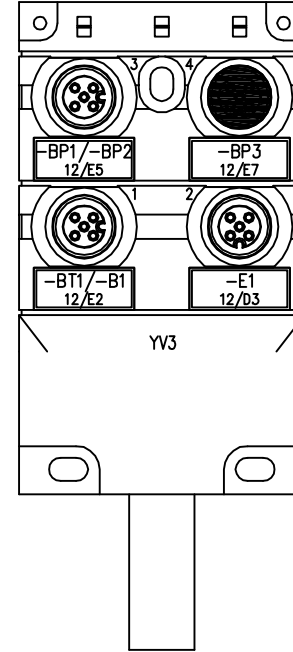
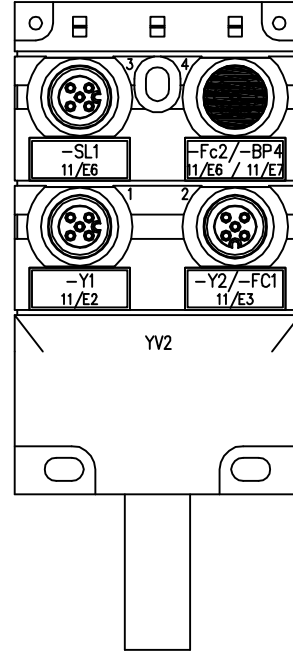
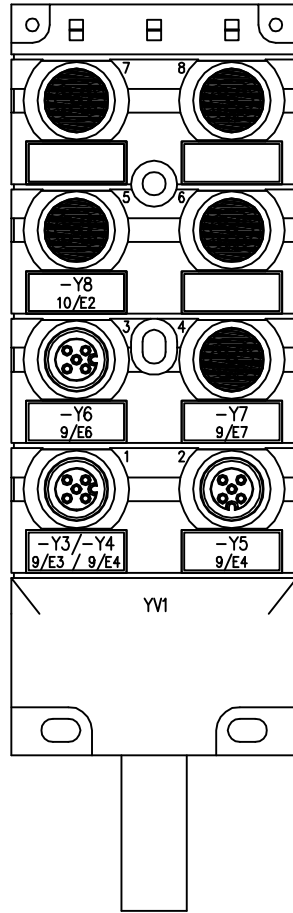
AFS 404 600

Checked :

Ing. Oscar

Date: 11/01/2011

Following 13



The design and drawings are property of Tesmec SpA, copying and unauthorized disclosure are forbidden

Electric scheme

SOCKET LIST

Drawn: Patani

Drawing Nr. S01-00010  
Archive Nr. S01

Sheet 13 of 38

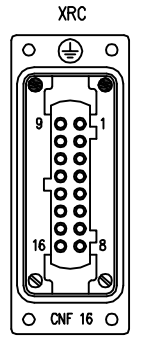
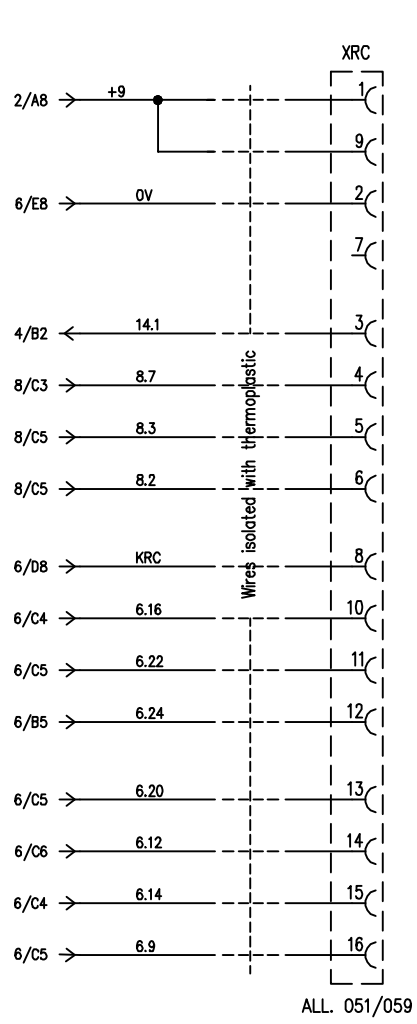
Grassobbio BG via Zanica, 17/a - Italy - Email: info@tesmec.it tel: +39 035 4232911 fax: +39 035 4522445  
Sede di Endine Galiano BG via Pertegalli - Italy - tel: +39 035 825024 fax: +39 035 826375

Design : AFS 404 600

Checked : Ing. Oscar

Date: 11/01/2011

Following 14



Remote connector  
view side contacts  
● Code PIN



The design and drawings are property of Tesmec SpA, copying and unauthorized disclosure are forbidden

Electric scheme

OPT REMOTE CONTROL

Drawn: Patani

Drawing Nr. S01-00010  
Archive Nr. S01

Sheet 14 of 38

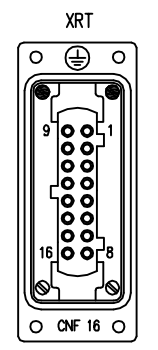
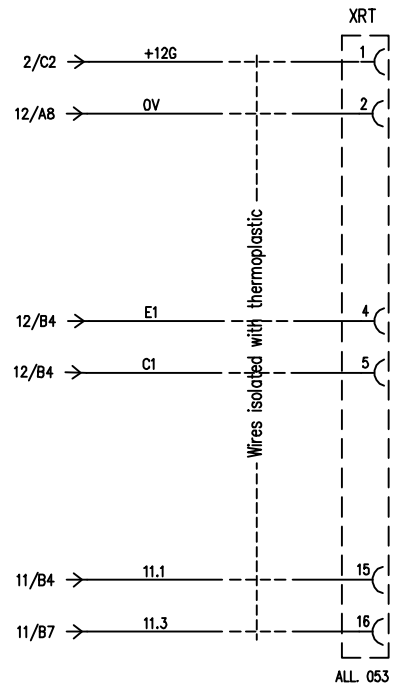
Grassobbio BG via Zanica, 17/a - Italy - Email: info@tesmec.it tel: +39 035 4232911 fax: +39 035 4522445  
Sede di Endine Galano BG via Pertegalli - Italy - tel: +39 035 825024 fax: +39 035 826375

Design : AFS 404 600

Checked : Ing. Oscar

Date: 11/01/2011

Following 15



Remote connector  
view side contacts  
● Code PIN



The design and drawings are property of Tesmec SpA, copying and unauthorized disclosure are forbidden

Electric scheme

OPT RECORDING PULL CONTROL

Drawn: Patani

Drawing Nr. S01-00010  
Archive Nr. S01

Sheet 15 of 38

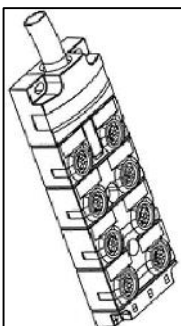
Grassobbio BG via Zanica, 17/a - Italy - Email: info@tesmec.it tel: +39 035 4232911 fax: +39 035 4522445  
Sede di Endine Galano BG via Pertegalli - Italy - tel: +39 035 825024 fax: +39 035 826375

Design : AFS 404 600

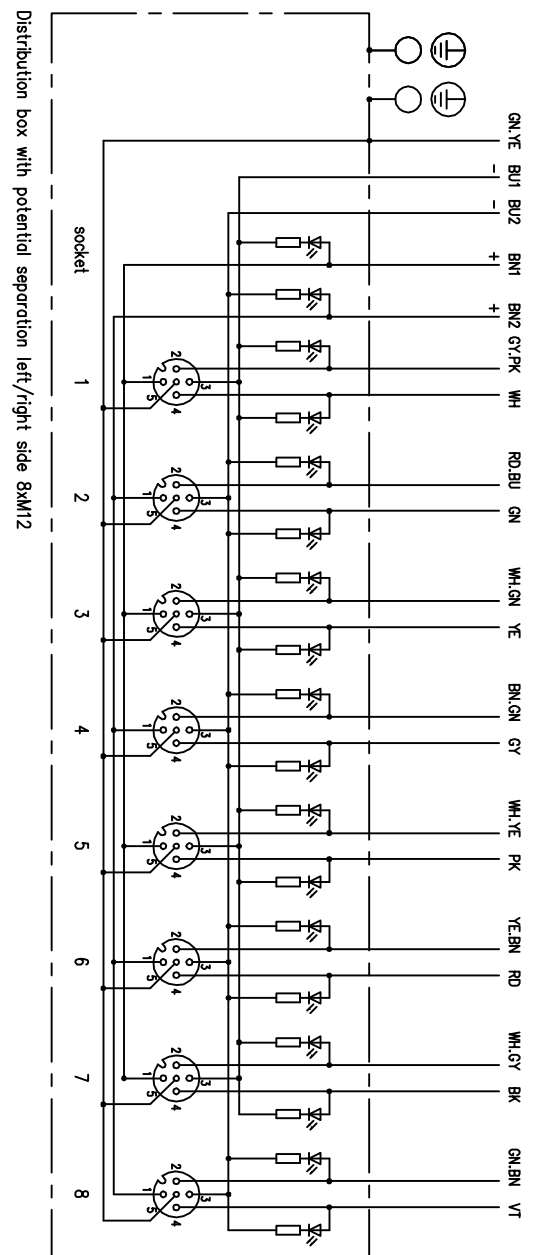
Checked : Ing. Oscar

Date: 11/01/2011

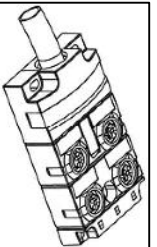
Following 16



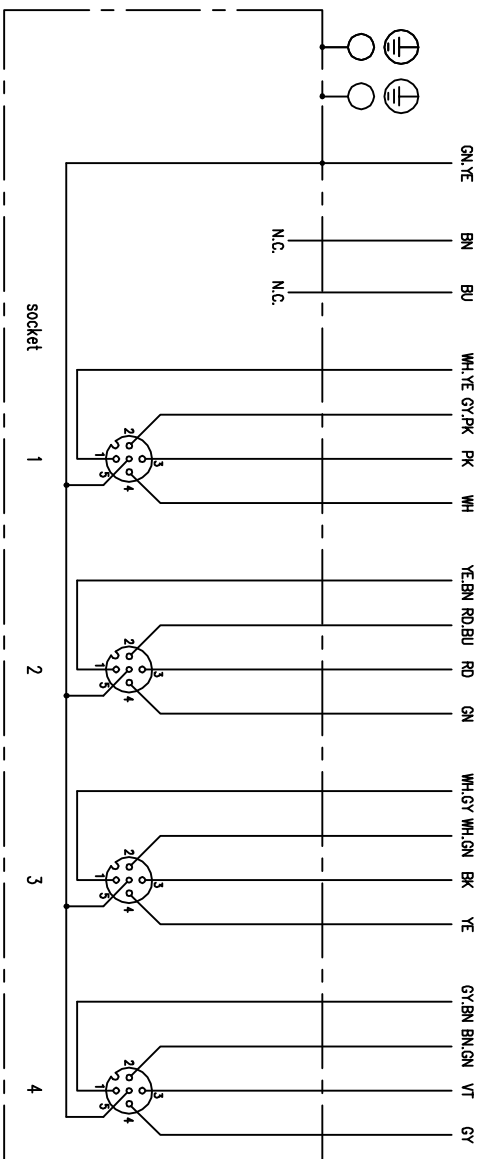
Schematic diagram  
Connecting cable



Distribution box with potential separation left/right side 8xM12



Schematic diagram  
Connecting cable



Distribution box Pin to Pin 4xM12; wire brown and blue cut



Grassobbio BG via Zanica, 17/a - Italy - Email: info@tesmec.it tel: +39 035 4232911 fax: +39 035 4522445  
Sede di Endine Galano BG via Pertegalli - Italy - tel: +39 035 825024 fax: +39 035 826375

The design and drawings are property of Tesmec SpA, copying and unauthorized disclosure are forbidden

Electric scheme

WIRING MULTISOCKETS

Design : AFS 404 600

Drawn: Patani

Checked : Ing. Oscar

Drawing Nr. S01-00010  
Archive Nr. S01

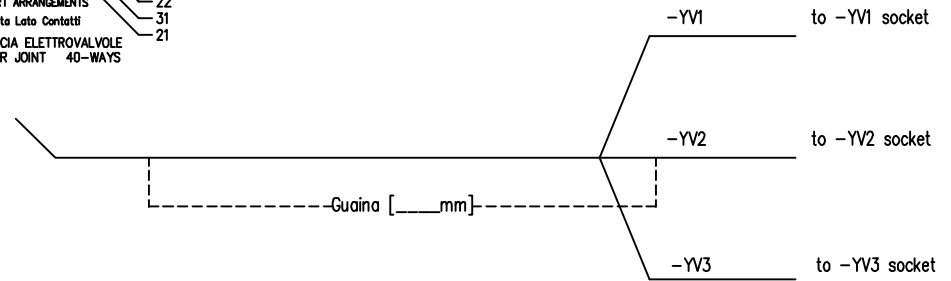
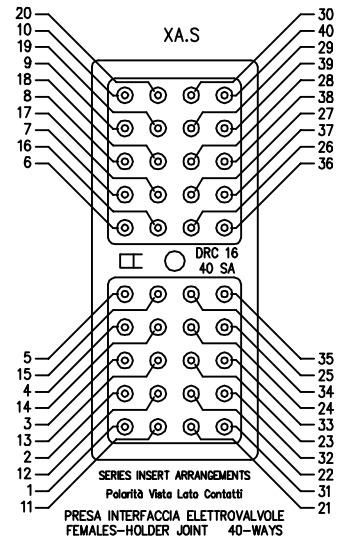
Date: 11/01/2011

Sheet 16 of 38

Following 17

**XA.S**  
PRESA INTERFACCIA ELETTROVALVOLE  
FEMALES-HOLDER JOINT 40-WAYS  
Tipo DRC 16 40SA

Pin	Wire	Position	Section	Colour	Designation
1	0V	9/C1	0.75	BU1	COMMON - YV1
2	7.8	9/C3	0.34	GY.PK	Y3 - YV1
3	9.4	9/C6	0.34	WH.GN	Y6A - YV1
4	10.1	10/C2	0.34	PK	0.34
5	7.5	11/C2	0.34	WH.YE	Y1A - YV2
6	+4	11/C6	0.34	GY.BN	FC2 - YV2 [OPT 071]
7	7.7	11/C3	0.34	YE.BN	Y2 - YV2
8	3.9	12/C7	0.34	VT	BP3 - YV3 [OPT 005]
9	0V	12/C7	0.34	GY	BP3 - YV3 [OPT 005]
10	F1	12/C3	0.34	YE.BN	E1 (F) - YV3
11	0V	9/C1	0.75	BU2	COMMON - YV1
12	9.1	9/C3	0.34	WH	Y4 - YV1
13	9.5	9/C6	0.34	YE	Y6B - YV1
14	3.1	11/C5	0.34	WH.GY	SL1 (T) - YV2
15	7.4	11/C2	0.34	15	Y1A - YV2
16	11.2	11/C7	0.34	BN.GN	FC2 - YV2 [OPT 071]
17	7.6	11/C4	0.34	RD.BU	Y2 - YV2
18	3.2	12/C2	0.34	WH.YE	BT1 - YV3
19	3.7	12/C5	0.34	WH.GN	BP1 - YV3
20	A1	12/C4	0.34	RD.BU	E1 (A) - YV3
21	+5	9/C1	0.75	BN1	COMMON + YV1
22	9.2	9/C4	0.34	RD.BU	Y5A - YV1
23	7.10	9/C7	0.34	BN.GN	Y7A - YV1 [OPT 071]
24	3.6	11/C5	0.34	WH.GN	SL1 (W) - YV2
25	7.3	11/C2	0.34	PK	Y1B - YV2
26	+10	11/C7	0.34	VT	BP4 - YV2 [OPT 053]
27	+4	11/C4	0.34	RD	FC1 - YV2
28	+4	12/C2	0.34	PK	B1 - YV3
29	0V	12/C5	0.34	BK	BP1/BP2 - YV3
30	C1	12/C4	0.34	RD	E1 (C) - YV3
31	+5	9/C2	0.75	BN2	COMMON + YV1
32	9.3	9/C5	0.34	GN	Y5B - YV1
33	7.9	9/C8	0.34	GY	Y7B - YV1 [OPT 071]
34	0V	11/C6	0.34	YE	SL1 (0V) - YV2
35	7.2	11/C3	0.34	WH	Y1B - YV2
36	11.3	11/C7	0.34	GY	BP4 - YV2 [OPT 053]
37	11.1	11/C4	0.34	GN	FC1 - YV2
38	12.1	12/C3	0.34	WH	B1 - YV3
39	3.8	12/C6	0.34	YE	BP2 - YV3
40	E1	12/C4	0.34	GN	E1 (E) - YV3



The design and drawings are property of Tesmec SpA, copying and unauthorized disclosure are forbidden

Electric scheme

XA WIRING

Drawn: Patani

Drawing Nr. S01-00010  
Archive Nr. S01

Sheet 17 of 38

Grassobbio BG via Zanica, 17/a - Italy - Email: info@tesmec.it tel: +39 035 4232911 fax: +39 035 4522445  
Sede di Endine Galiano BG via Pertegalli - Italy - tel: +39 035 825024 fax: +39 035 826375

Design : AFS 404 600

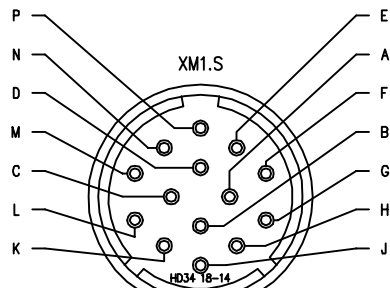
Checked : Ing. Oscar

Date: 11/01/2011

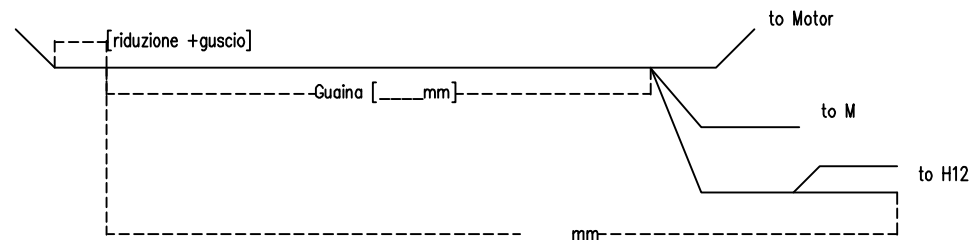
Following 18

X2.S  
 CONNETTORE POTENZA MACCHINA  
 FEMALES-HOLDER JOINT 14-WAYS  
 Tipo HD36 18-14SN

Pin	Wire	Position	Section	Colour	Designation
A	3.3	3/D4			
B	+5	2/D6			
C	2.9	2/D4			
D	2.11	2/D5			
E	8.5	2/C7			
F	3.4	3/D5			
G	3.4	3/D5			
H	0V	4/D4			
J	2.5	4/D4			
K	2.12	2/D6			
L	2.7	2/D3			
M	+1	2/C2			
N	2.4	2/D3			
P	8.4	2/C7			

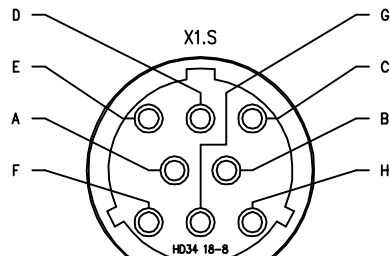


SERIES INSERT ARRANGEMENTS  
 Polarità Vista Retro Contatti  
 CONNETTORE POTENZA MACCHINA  
 FEMALES-HOLDER JOINT 14-WAYS

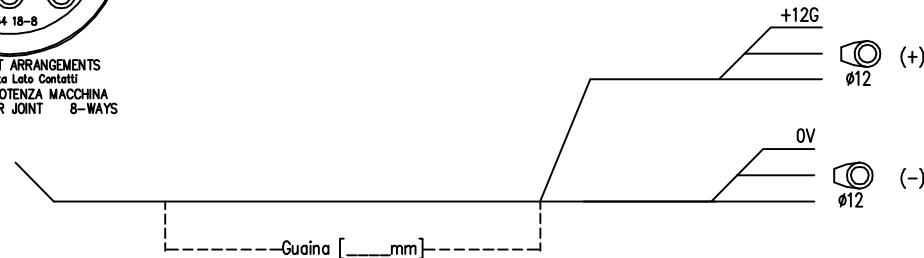


X1.S  
 CONNETTORE POTENZA MACCHINA  
 FEMALES-HOLDER JOINT 8-WAYS  
 Tipo HD 36 18-8SN

Pin	Wire	Position	Section	Colour	Designation
A					
B					
C	+12G	2/D1	2.5	RD	+ BATTERY
D	+12G	2/D1	2.5	RD	+ BATTERY
E	+12G	2/D1	2.5	RD	+ BATTERY
F	0V	2/E1	2.5	BK	- BATTERY
G	0V	2/E1	2.5	BK	- BATTERY
H	0V	2/E1	2.5	BK	- BATTERY



SERIES INSERT ARRANGEMENTS  
 Polarità Vista Lato Contatti  
 CONNETTORE POTENZA MACCHINA  
 FEMALES-HOLDER JOINT 8-WAYS



The design and drawings are property of Tesmec SpA, copying and unauthorized disclosure are forbidden

Electric scheme

X1/X2 WIRING

Drawn: Patani

Drawing Nr. S01-00010  
 Archive Nr. S01

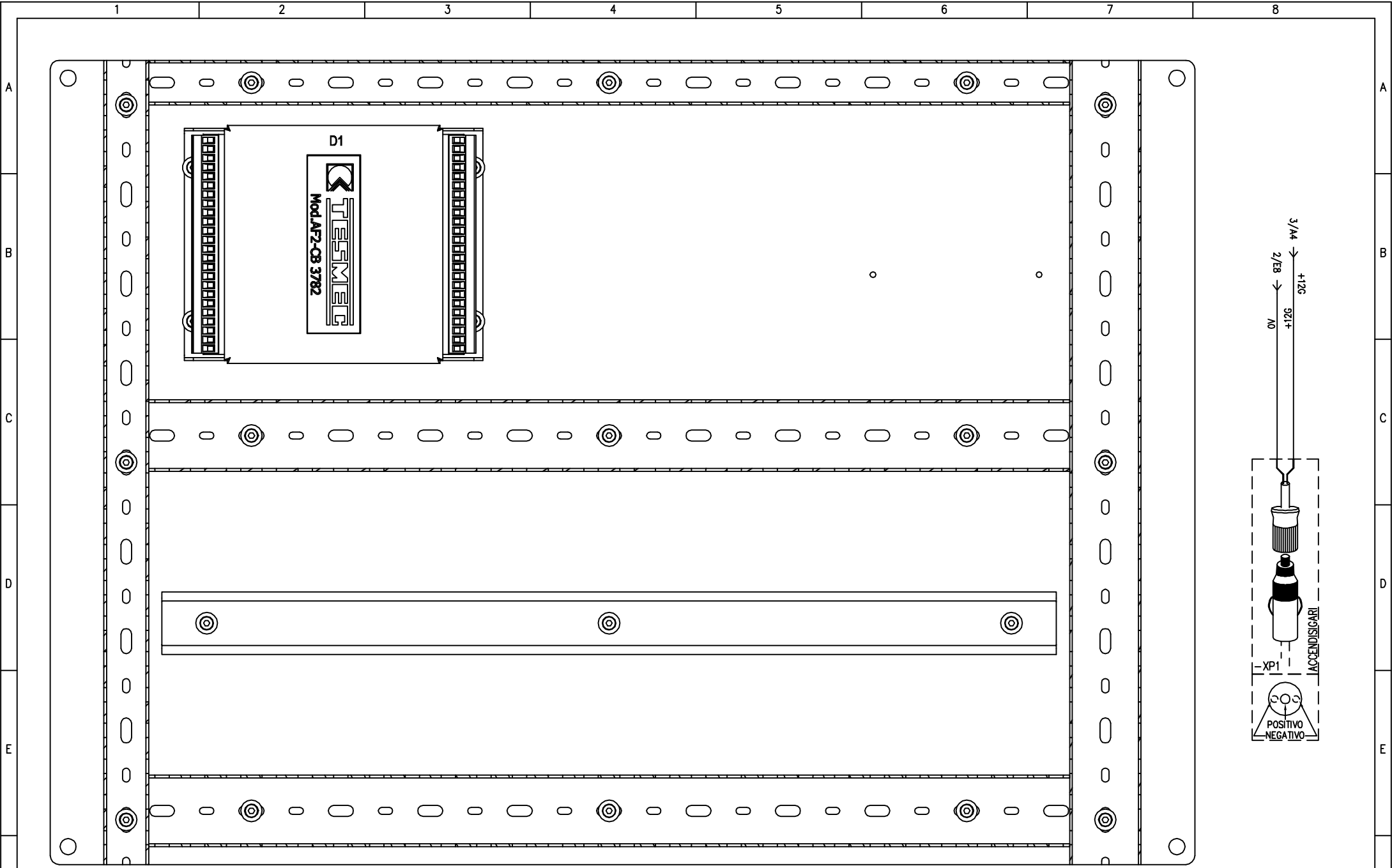
Sheet 18 of 38

Design : AFS 404 600

Checked : Ing. Oscar

Date: 11/01/2011

Following 19



The design and drawings are property of Tesmec SpA, copying and unauthorized disclosure are forbidden

Electric scheme

ELECTRIC BOARD TOPOGRAPHIC

Drawn: Patani

Drawing Nr. S01-00010  
Archive Nr. S01

Sheet 19 of 38

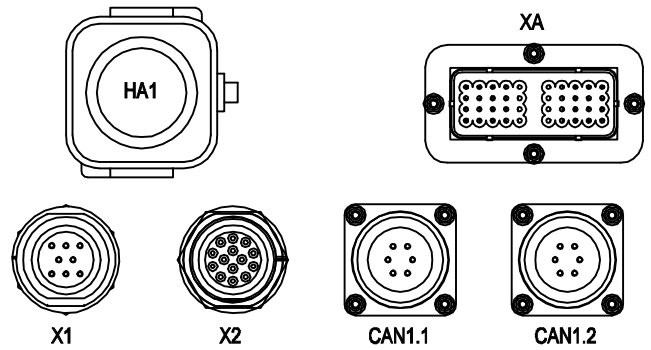
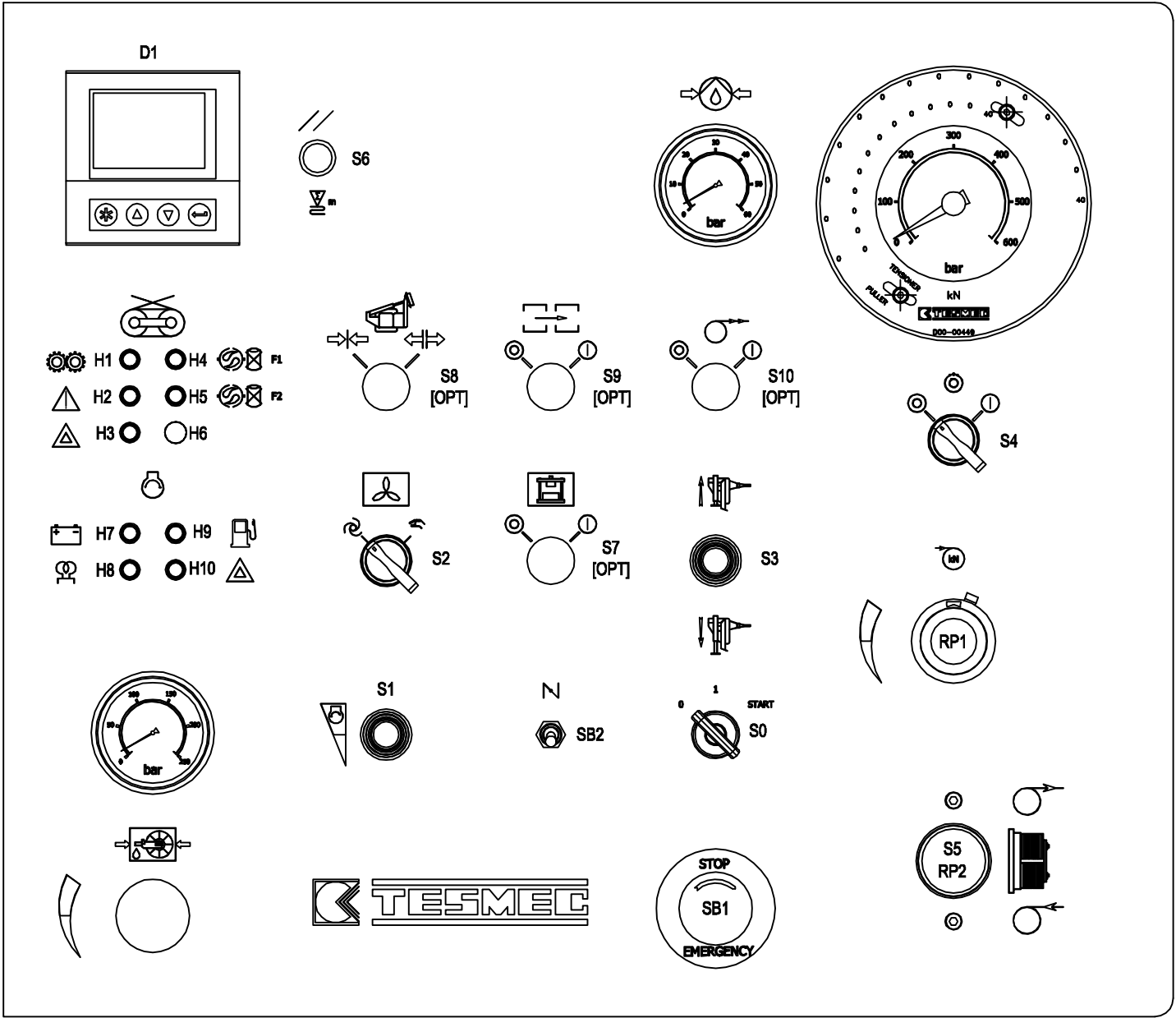
Grassobbio BG via Zanica, 17/a - Italy - Email: info@tesmec.it tel: +39 035 4232911 fax: +39 035 4522445  
Sede di Endine Galiano BG via Pertegalli - Italy - tel: +39 035 825024 fax: +39 035 826375

Design : AFS 404 600

Checked : Ing. Oscar

Date: 11/01/2011

Following 20



The design and drawings are property of Tesmec SpA, copying and unauthorized disclosure are forbidden

Electric scheme

CONTROL PANEL TOPOGRAPHIC

Drawn: Patani

Drawing Nr. S01-00010  
Archive Nr. S01

Sheet 20 of 38

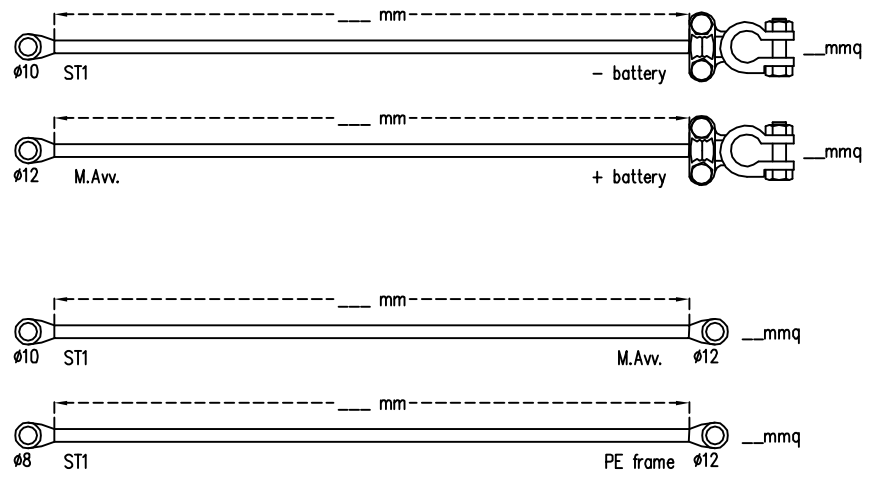
Grassobbio BG via Zanica, 17/a - Italy - Email: info@tesmec.it tel: +39 035 4232911 fax: +39 035 4522445  
Sede di Endine Galiano BG via Pertegalli - Italy - tel: +39 035 825024 fax: +39 035 826375

Design : AFS 404 600

Checked : Ing. Oscar

Date: 11/01/2011

Following 21



The design and drawings are property of Tesmec SpA, copying and unauthorized disclosure are forbidden

Electric scheme

POWER/ BATTERY PREWIRED CABLE

Drawn: Patani

Drawing Nr. S01-00010  
Archive Nr. S01

Sheet 21 of 38

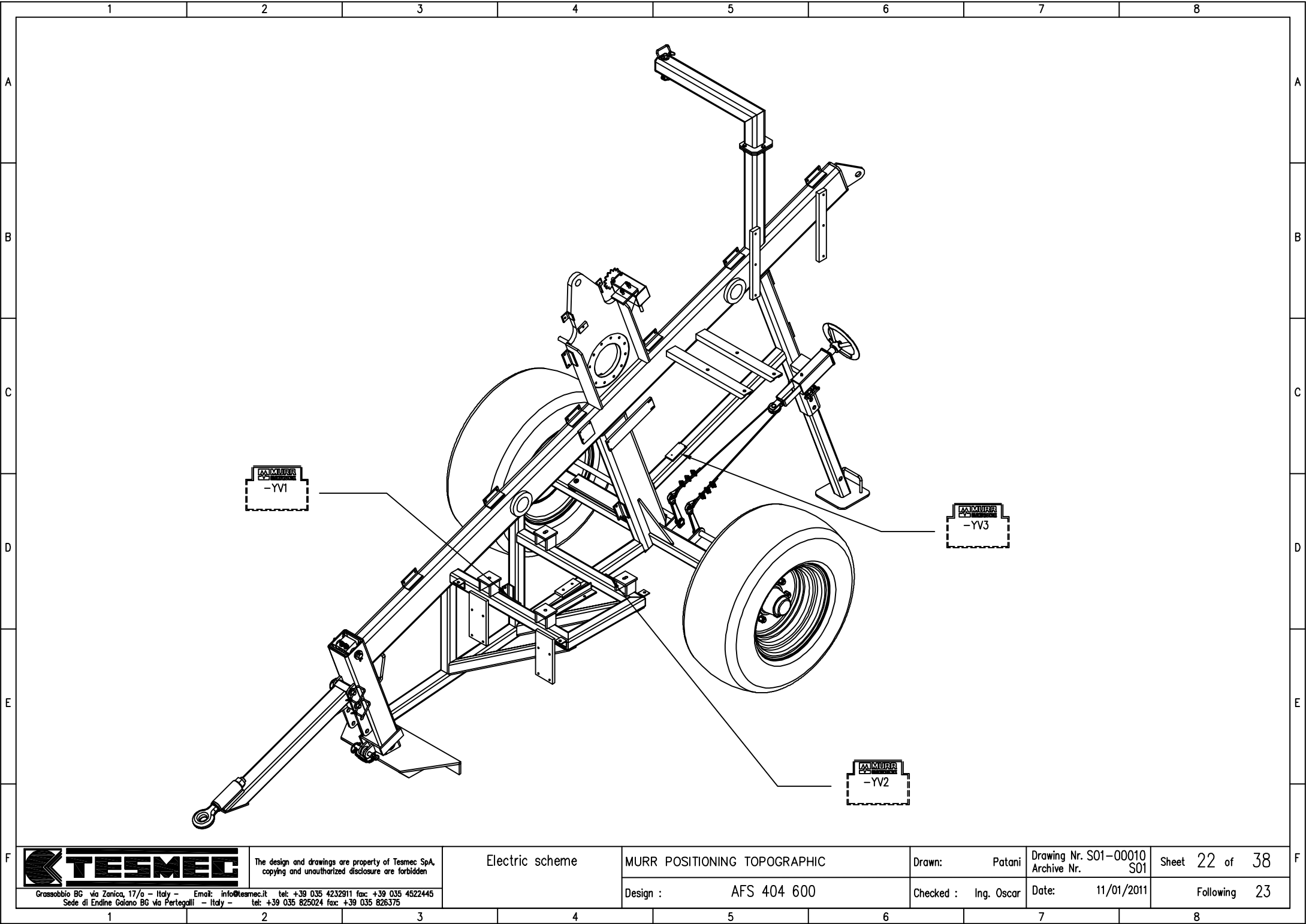
Grassobbio BG via Zanica, 17/a - Italy - Email: info@tesmec.it tel: +39 035 4232911 fax: +39 035 4522445  
Sede di Endine Galano BG via Pertegalli - Italy - tel: +39 035 825024 fax: +39 035 826375

Design : AFS 404 600

Checked : Ing. Oscar

Date: 11/01/2011

Following 22



The design and drawings are property of Tesmec SpA, copying and unauthorized disclosure are forbidden

Electric scheme

MURR POSITIONING TOPOGRAPHIC

Drawn: Patani

Drawing Nr. S01-00010  
Archive Nr. S01

Sheet 22 of 38

Grassobbio BG via Zanica, 17/a - Italy - Email: info@tesmec.it tel: +39 035 4232911 fax: +39 035 4522445  
Sede di Endine Galano BG via Pertegalli - Italy - tel: +39 035 825024 fax: +39 035 826375

Design : AFS 404 600

Checked : Ing. Oscar

Date: 11/01/2011

Following 23

1	2		3	4	5	6	7	8	
Sigla	Codice	Pos.	Descrizione da Archivio Materiali	Qto Tot	Funzione Componente	Function Component			
A	-A1	00000000	2/D2	ENGINE.PART.....(CODICI MOTORE)	2 2	ASSIEME MONTAGGIO MOTORE "CUMMINS F2"			
	-B1	00000000	3/D5	ENGINE.PART.....(CODICI MOTORE)	1 1	CONTATTO PRESSIONE OLIO MOTORE			
	-B1	99999999	12/D2	IDRAULIC.PART.....(CODICE IDRAULICO)	1 1	TERMOSTATO OLIO IDRAULICO			
B	-BP1	99999999	12/D5	IDRAULIC.PART.....(CODICE IDRAULICO)	1 1	FILTRO IDRAULICO F1 INTASATO			
	-BP2	99999999	12/D5	IDRAULIC.PART.....(CODICE IDRAULICO)	1 1	FILTRO IDRAULICO F2 INTASATO			
	-BP3	99999999	12/D7	IDRAULIC.PART.....(CODICE IDRAULICO)	1 1	FILTRO IDRAULICO F3 INTASATO [OPT 005]			
	-BP4	V00-8510-072	11/D7	TRASDUTTORE PRESSIONE 0-400 BAR - 8-24 V	1 1	TRASDUTTORE DI PRESSIONE [OPT 053]			
C	-BT1	00000000	3/D4	ENGINE.PART.....(CODICI MOTORE)	1 1	SONDA DI TEMPERATURA ACQUA MOTORE			
	-BT2	V00-8510-057	12/D2	TRASMETTITORE TEMPERATURA 12 / 24 V - FA	1 1	SENSORE TEMPERATURA OLIO IDRAULICO			
	CAN1.1-F	V00-2227-061	6/E3	CONNETTORE - Nø 5 + PE POLI - FEMMINA FI	1 1	CONNETTORE CAN			
D	CAN1.1-M	V00-2227-062	6/E3	CONNETTORE - Nø 5 + PE POLI - MASCHIO VO	1 1	CONNETTORE CAN			
	CAN1.2-F	V00-2227-061	6/E5	CONNETTORE - Nø 5 + PE POLI - FEMMINA FI	1 1	CONNETTORE CAN			
	CAN1.2-M	V00-2227-062	6/E5	CONNETTORE - Nø 5 + PE POLI - MASCHIO VO	1 1	CONNETTORE CAN			
	CD1	99999999	4/B5	IDRAULIC.PART.....(CODICE IDRAULICO)	1 1	CONTATTO DINAMOMETRO			
E	D1	V00-8600-008	3/D2	DISPLAY GRAFICO 9 - 32 V - DSF : J1939 E	1 1	DISPLAY MULTIFUNZIONE "ENGI METER"			
	-	V00-2225-045	3/D2	CONNETTORE + PIN X ENGI METER - DSF : DT0	1 1				
	-E1	V00-8510-033	12/D3	ENCODER ASSOLUTO - D.ALBERO 8 MM - FLANG	1 1	ENCODER			
F	-Fc1	V00-8510-036	11/D4	FINECORSO A PULSANTE CON ROTELLA - CONTA	1 1	FINECORSO RIDUTTORE			



The design and drawings are property of Tesmec SpA, copying and unauthorized disclosure are forbidden

Electric scheme

COMPONENT LIST

Drawn: Patani

Drawing Nr. S01-00010  
Archive Nr. S01

Sheet 23 of 38


Grassobbio BG via Zanica, 17/a - Italy - Email: info@tesmec.it tel: +39 035 4232911 fax: +39 035 4522445  
Sede di Endine Gaiano BG via Pertegalli - Italy - tel: +39 035 825024 fax: +39 035 826375

Design : AFS 404 600

Checked : Ing. Oscar

Date: 11/01/2011

Following 24

1	2	3	4	5	6	7	8						
Sigla	Codice	Pos.	Descrizione da Archivio Materiali	Qto Tot	Funzione Componente	Function Component							
A	-Fc2	V00-8510-036	11/D6	FINECORS A PULSANTE CON ROTELLA - CONTA	1 1	FINECORS BLOCCAFUNE [OPT 071]	A						
	FU1	V00-8401-036	2/B2	FUSIBILE A LAME 5 A BEIGE INTERASSE LAME	1 1	FUSIBILE PROTEZIONE RELE AVVIAMENTO							
	FU2	V00-8401-011	2/B2	FUSIBILE A LAME 3 A VIOLETTO INTERASSE L	1 1	FUSIBILE PROTEZIONE ARRESTO MOTORE							
B	FU3	V00-8401-011	2/B2	FUSIBILE A LAME 3 A VIOLETTO INTERASSE L	1 1	FUSIBILE PROTEZIONE ARRESTO MOTORE	B						
	FU4	V00-8401-036	2/B2	FUSIBILE A LAME 5 A BEIGE INTERASSE LAME	1 1	FUSIBILE PROTEZIONE LINEA +5							
	FU5	V00-8401-037	2/A2	FUSIBILE A LAME 7.5 A MARRONE INTERASSE	1 1	FUSIBILE PROTEZIONE ELETTRORIVOLVILE							
	FU6	V00-8401-054	2/A2	FUSIBILE A LAME 1 A NERO INTERASSE LAME	1 1	FUSIBILE PROTEZIONE ENIGMETER							
C	FU7	V00-8401-037	2/A2	FUSIBILE A LAME 7.5 A MARRONE INTERASSE	1 1	FUSIBILE PROTEZIONE SCHEDA	C						
	FU8	V00-8401-020	2/A2	FUSIBILE A LAME 10 A ROSSO INTERASSE LAM	1 1	FUSIBILE PROTEZIONE ACCELERATORE							
	FU9	V00-8401-011	2/A2	FUSIBILE A LAME 3 A VIOLETTO INTERASSE L	1 1	FUSIBILE PROTEZIONE COMANDO A DISTANZA [OPT 051]							
D	FU10	V00-8401-054	2/A2	FUSIBILE A LAME 1 A NERO INTERASSE LAME	1 1	FUSIBILE PROTEZIONE REGISTRATORE TIRO [OPT 053]	D						
	FU11	V00-8401-064	2/C3	FUSIBILE A LAME 80 A TRASPARENTE INTERAS	1 1	FUSIBILE PROTEZIONE GRIGLIA PRERISCALDO							
	-GB1	V00-1500-003	2/D1	BATTERIA 100 AH 12 V - EN 760 A - LUNGH.	1 1	BATTERIA DI AVVIAMENTO							
E	- V00-2229-003	2/D1	MORSETTO BATTERIA POLO POSITIVO CAVO SEZ	1 1			E						
	- V00-2229-004	2/D1	COPRIMORSETTO POLO POSITIVO BATTERIA ROS	1 1									
	- V00-2229-005	2/D1	MORSETTO BATTERIA POLO NEGATIVO CAVO SEZ	1 1									
	- V00-2229-006	2/D1	COPRIMORSETTO POLO NEGATIVO BATTERIA NER	1 1									
F	H1	V00-8400-023	11/B4	DIODO A LED - GIALLO 12 V DC - 8 MM - IP	1 1	LED RIDUTTORE FRENATURA RIDOTTA	F						
		The design and drawings are property of Tesmec SpA, copying and unauthorized disclosure are forbidden.		Electric scheme		COMPONENT LIST		Drawn: Patani		Drawing Nr. S01-00010 Archive Nr. S01		Sheet 24 of 38	
Grassobbio BG via Zanica, 17/a - Italy - Email: info@tesmec.it tel: +39 035 4232911 fax: +39 035 4522445 Sede di Endine Galiano BG via Pertegalli - Italy - tel: +39 035 825024 fax: +39 035 826375						Design : AFS 404 600		Checked : Ing. Oscar		Date: 11/01/2011		Following 25	

1	2		3	4	5	6	7	8	
Sigla	Codice	Pos.	Descrizione da Archivio Materiali	Qto Tot	Funzione Componente	Function Component			
A	H2	V00-8400-023	7/E3	DIODO A LED - GIALLO 12 V DC - 8 MM - IP	1 1	LED ALLARME SCHEDA	A		
	H3	V00-8400-022	4/D5	DIODO A LED - ROSSO 12 V DC - 8 MM - IP	1 1	SPIA ALLARME TIRO MASSIMO			
	H4	V00-8400-022	3/B6	DIODO A LED - ROSSO 12 V DC - 8 MM - IP	1 1	LED FILTRO IDRAULICO F1 INTASATO			
B	H5	V00-8400-022	3/B7	DIODO A LED - ROSSO 12 V DC - 8 MM - IP	1 1	LED FILTRO IDRAULICO F2 INTASATO	B		
	H6	V00-8400-022	3/B7	DIODO A LED - ROSSO 12 V DC - 8 MM - IP	1 1	LED FILTRO IDRAULICO F3 INTASATO			
	H7	V00-8400-022	2/C6	DIODO A LED - ROSSO 12 V DC - 8 MM - IP	1 1	LED ALLARME GENERATORE			
	H8	V00-8400-023	2/E3	DIODO A LED - GIALLO 12 V DC - 8 MM - IP	1 1	LED PRERISCALDO MOTORE			
C	H9	V00-8400-023	3/B6	DIODO A LED - GIALLO 12 V DC - 8 MM - IP	1 1	LED ALLARME LIVELLO CARBURANTE	C		
	H10	V00-8400-022	3/B5	DIODO A LED - ROSSO 12 V DC - 8 MM - IP	1 1	LED PRESSIONE OLIO MOTORE E TEMPERATURA ACQUA			
	H11	V00-2200-029	4/D6	LAMPADA ROTANTE 9/32 V - XENON REVOLUX :	1 1	LAMPEGGIANTE			
D		- V00-2200-030	4/D4	SUPPORTO TUBOLARE - XENON : 35.001.520	1 1		D		
	HA1	V00-8401-042	4/D6	AVVISATORE ACUSTICO 12 V 129 DB - IP 54	1 1	AVVISATORE ACUSTICO			
	K1	V00-8402-014	3/C5	RELE 12 V 2 SC - 8 A - FINDER : 46.52.9.	1 1	RELE ALLARME MOTORE			
		- V00-8402-020	3/C5	MODULO DIODO + LED 6-24 V DC/AC - FINDER	1 1				
E		- V00-8402-039	3/C5	ZOCOLO RELE 2SC MORSETTO A MOLLA MONTAG	1 1		E		
	K2	V00-8402-014	4/D3	RELE 12 V 2 SC - 8 A - FINDER : 46.52.9.	1 1	RELE EMERGENZA			
		- V00-8402-020	4/D3	MODULO DIODO + LED 6-24 V DC/AC - FINDER	1 1				
F		- V00-8402-039	4/D3	ZOCOLO RELE 2SC MORSETTO A MOLLA MONTAG	1 1		F		



The design and drawings are property of Tesmec SpA, copying and unauthorized disclosure are forbidden

Electric scheme

COMPONENT LIST

Drawn: Patani

Drawing Nr. S01-00010  
Archive Nr. S01

Sheet 25 of 38

Grassobbio BG via Zanica, 17/a - Italy - Email: info@tesmec.it tel: +39 035 4232911 fax: +39 035 4522445  
Sede di Endine Galiano BG via Pertegalli - Italy - tel: +39 035 825024 fax: +39 035 826375

Design : AFS 404 600

Checked : Ing. Oscar

Date: 11/01/2011

Following 26

1	2	3	4	5	6	7	8
Sigla	Codice	Pos.	Descrizione da Archivio Materiali	Qto Tot	Funzione Componente	Function Component	
A	K3	V00-8402-014	4/D4	RELE 12 V 2 SC - 8 A - FINDER : 46.52.9.	1 1	RELE ALLARME TIRO MAX	A
	- V00-8402-020	4/D4	MODULO DIODO + LED 6-24 V DC/AC - FINDER	1 1			
	- V00-8402-039	4/D4	ZOCCOLO RELE 2SC MORSETTO A MOLLA MONTAG	1 1			
B	K4	V00-8402-014	5/D2	RELE 12 V 2 SC - 8 A - FINDER : 46.52.9.	1 1	RELE VENTOLA RADIATORE	B
	- V00-8402-020	5/D2	MODULO DIODO + LED 6-24 V DC/AC - FINDER	1 1			
	- V00-8402-039	5/D2	ZOCCOLO RELE 2SC MORSETTO A MOLLA MONTAG	1 1			
C	K5	V00-8402-014	5/D3	RELE 12 V 2 SC - 8 A - FINDER : 46.52.9.	1 1	RELE AUSILIARI	C
	- V00-8402-020	5/D3	MODULO DIODO + LED 6-24 V DC/AC - FINDER	1 1			
	- V00-8402-039	5/D3	ZOCCOLO RELE 2SC MORSETTO A MOLLA MONTAG	1 1			
D	K6	V00-8402-014	5/D5	RELE 12 V 2 SC - 8 A - FINDER : 46.52.9.	1 1	RELE STABILIZZATORE SALITA	D
	- V00-8402-020	5/D5	MODULO DIODO + LED 6-24 V DC/AC - FINDER	1 1			
	- V00-8402-039	5/D5	ZOCCOLO RELE 2SC MORSETTO A MOLLA MONTAG	1 1			
E	K7	V00-8402-014	5/D5	RELE 12 V 2 SC - 8 A - FINDER : 46.52.9.	1 1	RELE STABILIZZATORE DISCESA	E
	- V00-8402-020	5/D5	MODULO DIODO + LED 6-24 V DC/AC - FINDER	1 1			
	- V00-8402-039	5/D5	ZOCCOLO RELE 2SC MORSETTO A MOLLA MONTAG	1 1			
F	K8.1	V00-8402-014	5/D6	RELE 12 V 2 SC - 8 A - FINDER : 46.52.9.	1 1	RELE PRESSA	F
	- V00-8402-020	5/D6	MODULO DIODO + LED 6-24 V DC/AC - FINDER	1 1			
	- V00-8402-039	5/D6	ZOCCOLO RELE 2SC MORSETTO A MOLLA MONTAG	1 1			



The design and drawings are property of Tesmec SpA, copying and unauthorized disclosure are forbidden

Electric scheme

COMPONENT LIST

Drawn: Patani

Drawing Nr. S01-00010  
Archive Nr. S01

Sheet 26 of 38

Grassobbio BG via Zanica, 17/a - Italy - Email: info@tesmec.it tel: +39 035 4232911 fax: +39 035 4522445  
Sede di Endine Gaiano BG via Pertegalli - Italy - tel: +39 035 825024 fax: +39 035 826375

Design : AFS 404 600

Checked : Ing. Oscar

Date: 11/01/2011

Following 27

1

2

3

4

5

6

7

8

1	2	3	4	5	6	7	8
Sigla	Codice	Pos.	Descrizione da Archivio Materiali	Qtà Tot	Funzione Componente	Function Component	
A	K8.2	V00-8402-014	5/D6	RELE 12 V 2 SC - 8 A - FINDER : 46.52.9.	1 1	RELE PRESSA	
	-	V00-8402-020	5/D6	MODULO DIODO + LED 6-24 V DC/AC - FINDER	1 1		
	-	V00-8402-039	5/D6	ZOCOLO RELE 2SC MORSETTO A MOLLA MONTAG	1 1		
B	K9.1	V00-8402-014	6/D7	RELE 12 V 2 SC - 8 A - FINDER : 46.52.9.	1 1	RELE ABILITAZIONE COMANDO A DISTANZA	
	-	V00-8402-020	6/D7	MODULO DIODO + LED 6-24 V DC/AC - FINDER	1 1		
	-	V00-8402-039	6/D7	ZOCOLO RELE 2SC MORSETTO A MOLLA MONTAG	1 1		
C	K9.2	V00-8402-014	6/D8	RELE 12 V 2 SC - 8 A - FINDER : 46.52.9.	1 1	RELE ABILITAZIONE COMANDO A DISTANZA	
	-	V00-8402-020	6/D8	MODULO DIODO + LED 6-24 V DC/AC - FINDER	1 1		
	-	V00-8402-039	6/D8	ZOCOLO RELE 2SC MORSETTO A MOLLA MONTAG	1 1		
D	K9.3	V00-8402-014	6/D8	RELE 12 V 2 SC - 8 A - FINDER : 46.52.9.	1 1	RELE ABILITAZIONE COMANDO A DISTANZA	
	-	V00-8402-020	6/D8	MODULO DIODO + LED 6-24 V DC/AC - FINDER	1 1		
	-	V00-8402-039	6/D8	ZOCOLO RELE 2SC MORSETTO A MOLLA MONTAG	1 1		
E	K10	V00-8402-014	7/E4	RELE 12 V 2 SC - 8 A - FINDER : 46.52.9.	1 1	RELE FRENO NEGATIVO	
	-	V00-8402-020	7/E4	MODULO DIODO + LED 6-24 V DC/AC - FINDER	1 1		
	-	V00-8402-039	7/E4	ZOCOLO RELE 2SC MORSETTO A MOLLA MONTAG	1 1		
F	K11	V00-8402-014	7/E5	RELE 12 V 2 SC - 8 A - FINDER : 46.52.9.	1 1	RELE MACCHINA ATTIVA	
	-	V00-8402-020	7/E5	MODULO DIODO + LED 6-24 V DC/AC - FINDER	1 1		
	-	V00-8402-039	7/E5	ZOCOLO RELE 2SC MORSETTO A MOLLA MONTAG	1 1		



The design and drawings are property of Tesmec SpA, copying and unauthorized disclosure are forbidden

Electric scheme

COMPONENT LIST

Drawn: Patani

Drawing Nr. S01-00010  
Archive Nr. S01

Sheet 27 of 38

Grassobbio BG via Zanica, 17/a - Italy - Email: info@tesmec.it tel: +39 035 4232911 fax: +39 035 4522445  
Sede di Endine Gaiano BG via Pertegalli - Italy - tel: +39 035 825024 fax: +39 035 826375

Design : AFS 404 600

Checked : Ing. Oscar

Date: 11/01/2011

Following 28

1	2		3	4	5	6	7	8	
Sigla	Codice	Pos.	Descrizione da Archivio Materiali	Qto Tot	Funzione Componente	Function Component			
A	K12	V00-8402-014	7/E6	RELE 12 V 2 SC - 8 A - FINDER : 46.52.9.	1 1	RELE BLOCCAFUNE CHIUSO			
		- V00-8402-020	7/E6	MODULO DIODO + LED 6-24 V DC/AC - FINDER	1 1				
		- V00-8402-039	7/E6	ZOCCOLO RELE 2SC MORSETTO A MOLLA MONTAG	1 1				
B	K13	V00-8402-014	2/D4	RELE 12 V 2 SC - 8 A - FINDER : 46.52.9.	1 1	RELE PRERISCALDO			
		- V00-8402-040	2/D4	MODULO TEMPORIZZATORE 12-24 V DC/AC - FI	1 1				
		- V00-8402-039	2/D4	ZOCCOLO RELE 2SC MORSETTO A MOLLA MONTAG	1 1				
C	K14	V00-8402-001	2/D4	RELE 12 V 1 NO - 80 A - BOSCH : 03330060	1 1	RELE GRIGLIA MOTORE			
	M	V00-8500-018	2/D7	ATTUATORE LINEARE LA1 12 V - 5.8 A - FOR	1 1	ATTUATORE LINEARE			
	N1	V00-8500-025	6/B2	SCHEDA CONTROLLO TIRO AF3-CV - ELTON : 3	1 1	SCHEDA COMANDO CABESTANO			
D		- V00-2227-046	6/B2	CONNETTORE MSTB 2.5/24-ST5-5.08 - Nø 24	2 2				
	N2	V00-8500-041	8/C3	SCHEDA CONTROLLO VELOCITA CON INTERFACCI	1 1	SCHEDA ACCELERATORE			
	-PC1	V00-8400-018	4/C3	MODULO PORTACOMPONENTI 5 - WEIDMULLER :	1 1	PORTACOMPONENTI			
E	Rcan1	V00-8400-034	3/C3	RESISTENZA 120 OHM 1/4 W - RS : 135-780	1 1	RESISTENZA CAN2			
	Rcan2	V00-8400-034	6/E3	RESISTENZA 120 OHM 1/4 W - RS : 135-780	1 1	RESISTENZA TERMINALE CAN1.1			
	Rcan3	V00-8400-034	6/E4	RESISTENZA 120 OHM 1/4 W - RS : 135-780	1 1	RESISTENZA TERMINALE CAN1.2			
F	-RP1	V00-8500-016	6/C4	POTENZIOMETRO ROTATIVO - Nø 3 GIRI 5 KOH	1 1	POTENZIOMETRO			
		- V00-8500-012	6/C4	MANOPOLA GRADUATA POTENZIOMETRO D. 46 -	1 1				
	S0	V00-8401-015	2/C1	CHIAVE AVVIAMENTO MOTORE - COBO : 14.134	1 1	INTERRUTTORE AVVIAMENTO MOTORE			



The design and drawings are property of Tesmec SpA, copying and unauthorized disclosure are forbidden

Electric scheme

COMPONENT LIST

Drawn: Patani

Drawing Nr. S01-00010  
Archive Nr. S01

Sheet 28 of 38


Grassobbio BG via Zanica, 17/a - Italy - Email: info@tesmec.it tel: +39 035 4232911 fax: +39 035 4522445  
Sede di Endine Gaiano BG via Pertegalli - Italy - tel: +39 035 825024 fax: +39 035 826375


Design : AFS 404 600

Checked : Ing. Oscar

Date: 11/01/2011

Following 29

	1	2	3	4	5	6	7	8			
	Sigla	Codice	Pos.	Descrizione da Archivio Materiali	Qto Tot	Funzione Componente	Function Component				
A	S1	V00-8410-011	8/C4	MANIPOLATORE N° 3 POS. TEMPORANEE NERO -	1 1	MANIPOLATORE ACCELERATORE		A			
	-	V00-8410-006	8/C6	CONTATTO NA - CEMA : P9B10VN	2 2						
B	S2	V00-8410-015	5/A2	SELETTORE A LEVA LUNGA - N° 2 POS.FISSE	1 1	SELETTORE VENTOLA RADIATORE		B			
	-	V00-8410-006	5/A2	CONTATTO NA - CEMA : P9B10VN	1 1						
	-	V00-8410-005	5/A2	ALIMENTAZIONE - CEMA : P9PDNV0	1 1						
	-	V00-2200-017	5/D2	LAMPADA BA 9S 12 V 3 W - OSRAM : 3894	1 1						
C	S3	V00-8410-011	5/B5	MANIPOLATORE N° 3 POS. TEMPORANEE NERO -	1 1	MANIPOLATORE STABILIZZATORE		C			
	-	V00-8410-006	5/B5	CONTATTO NA - CEMA : P9B10VN	2 2						
	S4	V00-8410-008	6/A4	SELETTORE A LEVA LUNGA - N° 2 POS.FISSE	1 1	SELETTORE IMPOSTAZIONE TIRO					
	-	V00-8410-002	6/A4	CONTATTO NA/NC - CEMA : P9B11VN	1 1						
	-	V00-8410-005	6/A5	ALIMENTAZIONE - CEMA : P9PDNV0	1 1						
D		-	V00-2200-017	6/A7	LAMPADA BA 9S 12 V 3 W - OSRAM : 3894	1 1		D			
	S5	V00-8500-027	6/A5	MANIPOLATORE SEMPLICE - KIEPE : STO11B9P	1 1	MANIPOLATORE COMANDO CABESTANO					
	S6	V00-8430-006	7/B4	PULSANTE ROTONDO D. 16 NERO - IP 67	1 1	PULSANTE RESET CONTAMETRI					
E	S7	V00-8410-008	5/A6	SELETTORE A LEVA LUNGA - N° 2 POS.FISSE	1 1	SELETTORE PRESSA		E			
	-	V00-8410-006	5/A6	CONTATTO NA - CEMA : P9B10VN	1 1						
	-	V00-8410-005	5/A6	ALIMENTAZIONE - CEMA : P9PDNV0	1 1						
	-	V00-2200-017	5/D7	LAMPADA BA 9S 12 V 3 W - OSRAM : 3894	1 1						
F			The design and drawings are property of Tesmec SpA, copying and unauthorized disclosure are forbidden		Electric scheme		COMPONENT LIST		Drawn: Patani	Drawing Nr. S01-00010 Archive Nr. S01	Sheet 29 of 38
	Grassobbio BG via Zanica, 17/a - Italy - Email: info@tesmec.it tel: +39 035 4232911 fax: +39 035 4522445 Sede di Endine Gaiano BG via Pertegalli - Italy - tel: +39 035 825024 fax: +39 035 826375				Design : AFS 404 600		Checked : Ing. Oscar		Date: 11/01/2011		Following 30

1		2		3		4		5		6		7		8				
Sigla	Codice	Pos.	Descrizione da Archivio Materiali			Qto Tot	Funzione Componente				Function Component							
A	S8	V00-8410-021	5/B4	SELETTORE A LEVA LUNGA - Nø 3 POS. CON R			1 1	SELETTORE BLOCCAFUNE								A		
	-	V00-8410-006	5/B4	CONTATTO NA - CEMA : P9B10VN			2 2											
	-	V00-8410-005	5/B4	ALIMENTAZIONE - CEMA : P9PDNV0			1 1											
	-	V00-2200-017	6/A7	LAMPADA BA 9S 12 V 3 W - OSRAM : 3894			1 1											
B	S9	V00-8410-009	6/A3	SELETTORE A LEVA LUNGA - Nø 2 POS.FISSE			1 1	SELETTORE ACCOPPIAMENTO MACCHINE								B		
	-	V00-8410-006	6/A3	CONTATTO NA - CEMA : P9B10VN			1 1											
	-	V00-8410-005	6/A3	ALIMENTAZIONE - CEMA : P9PDNV0			1 1											
	-	V00-2200-017	6/A4	LAMPADA BA 9S 12 V 3 W - OSRAM : 3894			1 1											
C	S10	V00-8410-015	6/A6	SELETTORE A LEVA LUNGA - Nø 2 POS.FISSE			1 1	SELETTORE SINCRONISMO DI VELOCITA'								C		
	-	V00-8410-006	6/A6	CONTATTO NA - CEMA : P9B10VN			1 1											
	-	V00-8410-005	6/A6	ALIMENTAZIONE - CEMA : P9PDNV0			1 1											
	-	V00-2200-017	6/A6	LAMPADA BA 9S 12 V 3 W - OSRAM : 3894			1 1											
D	SB1	V00-8410-001	2/C3	PULSANTE EMERGENZA - D. FUNGO: 40 ROSSO			1 1	PULSANTE ARRESTO EMERGENZA								D		
	-	V00-8410-003	2/C3	TARGHETTA STOP - D 22 - D. TARGHETTA 59			1 1											
	-	V00-8410-004	2/C3	CONTATTO NC - CEMA : P9B01VN			1 1											
	-	V00-8410-006	4/B3	CONTATTO NA - CEMA : P9B10VN			1 1											
E	-SB2	V00-8430-001	3/B5	SELETTORE AVVIAMENTO A FREDDO - Nø 2 POS			1 1	INTERRUTTORE AVVIAMENTO A FREDDO								E		
	-SL1	V00-8510-074	11/D5	GALLEGGIANTE A LEVA REGOLABILE - L. 1106			1 1	SENSORE LIVELLO CARBURANTE										
F			The design and drawings are property of Tesmec SpA, copying and unauthorized disclosure are forbidden			Electric scheme		COMPONENT LIST				Drawn: Patani		Drawing Nr. S01-00010 Archive Nr. S01		Sheet 30 of 38		F
		Grassobio BG via Zanica, 17/a - Italy - Email: info@tesmec.it tel: +39 035 4232911 fax: +39 035 4522445 Sede di Endine Galiano BG via Pertegalli - Italy - tel: +39 035 825024 fax: +39 035 826375					Design : AFS 404 600				Checked : Ing. Oscar		Date: 11/01/2011		Following 31			

1		2		3		4		5		6		7		8	
Sigla	Codice	Pos.	Descrizione da Archivio Materiali			Qto Tot	Funzione Componente				Function Component				
A	-ST1	V00-8401-038	2/D1	INTERRUTTORE STACCABATTERIA 12-24 V - 25			1 1	INTERRUTTORE STACCABATTERIA							
	-	V00-8401-039	2/D1	CHIAVE PER INTERRUTTORE STACCABATTERIA :			1 1								
	VD1	V00-8400-011	5/C4	DIODO 1N4007			1 1	DIODO							
B	VD2	V00-8400-011	5/C4	DIODO 1N4007			1 1	DIODO							
	-W1	V00-2232-006	9/D3	CAVO M12 DIRITTO - L. 2 M - A Y - 2 CONN			1 1	CAVO DI COLLEGAMENTO ELETTROVALVOLE FRENO E RIAVVOLGITORE							
	-W2	V00-2232-053	9/D5	CAVO M12 DIRITTO - L. 1 M - A Y - 2 CONN			1 1	CAVO DI COLLEGAMENTO ELETTROVALVOLA VENTOLA							
	-W3	V00-2232-053	9/D6	CAVO M12 DIRITTO - L. 1 M - A Y - 2 CONN			1 1	CAVO DI COLLEGAMENTO ELETTROVALVOLA STABILIZZATORE							
C	-W4	V00-2232-053	9/D8	CAVO M12 DIRITTO - L. 1 M - A Y - 2 CONN			1 1	CAVO DI COLLEGAMENTO ELETTROVALVOLA CILINDRO BLOCCAFUNE							
	-W5	V00-2232-059	10/D3	CAVO M12 DIRITTO - L. 1 M - CONNETTORE			1 1	CAVO DI COLLEGAMENTO ELETTROVALVOLA PRESSA							
	-W6	V00-2232-003	11/D3	CAVO M12 DIRITTO - L. 2 M - A Y PIN TO P			1 1	CAVO DI COLLEGAMENTO ELETTROVALVOLA COMANDO POMPA							
	-W7	V00-2232-002	11/D4	CAVO M12 DIRITTO - L. 2 M - A Y - 3+3 FI			1 1	CAVO DI COLLEGAMENTO ELETTROVALVOLA REGOLAZIONE TIRO							
D	-W8	V00-2232-019	11/D6	CAVO M12 DIRITTO - L. 5 M - 4 FILI PVC -			1 1	CAVO DI COLLEGAMENTO SENSORE SERBATOIO CARBURANTE							
	-W9	V00-2232-002	11/D7	CAVO M12 DIRITTO - L. 2 M - A Y - 3+3 FI			1 1	CAVO DI COLLEGAMENTO FINECORSO BLOCCAFUNE E TRASDUTTORE							
	-W10	V00-2232-002	12/D3	CAVO M12 DIRITTO - L. 2 M - A Y - 3+3 FI			1 1	CAVO DI COLLEGAMENTO SENSORI TEMPERATURA OLIO IDRAULICO							
E	-W11	V00-2232-005	12/D4	CAVO M12 DIRITTO - L. 5 M - 4 FILI + SCH			1 1	CAVO DI COLLEGAMENTO ENCODER							
	-W12	V00-2232-002	12/D6	CAVO M12 DIRITTO - L. 2 M - A Y - 3+3 FI			1 1	CAVO DI COLLEGAMENTO INTASATORI							
	-W13	V00-2232-002	12/D7	CAVO M12 DIRITTO - L. 2 M - A Y - 3+3 FI			1 1	CAVO DI COLLEGAMENTO INTASATORE F3 [OPT 005]							
F	X1.P	V00-2225-003	2/E1	CONNETTORE - Nø 8 POLI - MASCHIO SIZE 12			1 1	CONNETTORE POTENZA A PANNELLO							



The design and drawings are property of Tesmec SpA, copying and unauthorized disclosure are forbidden

Electric scheme

COMPONENT LIST

Drawn: Patani

Drawing Nr. S01-00010  
Archive Nr. S01

Sheet 31 of 38


Grassobbio BG via Zanica, 17/a - Italy - Email: info@tesmec.it tel: +39 035 4232911 fax: +39 035 4522445  
Sede di Endine Galiano BG via Pertegalli - Italy - tel: +39 035 825024 fax: +39 035 826375

Design : AFS 404 600

Checked : Ing. Oscar

Date: 11/01/2011

Following 32

	1	2	3	4	5	6	7	8	
	Sigla	Codice	Pos.	Descrizione da Archivio Materiali	Qta Tot	Funzione Componente	Function Component		
A		- V00-2225-004	2/E1	CONTATTO MASCHIO TORNITO SEZIONE FILO: 1	$\frac{8}{8}$			A	
		- V00-2225-005	2/E1	RONDELLA PER CONNETTORI HD 34 - DEUTSCH	$\frac{1}{1}$				
		- V00-2225-007	2/E1	DADO PER CONNETTORI HD 34 - DEUTSCH : 11	$\frac{1}{1}$				
B	X1.S	V00-2225-025	2/E1	CONNETTORE - Nø 8 POLI - FEMMINA SIZE 12	$\frac{1}{1}$	CONNETTORE POTENZA VOLANTE		B	
		- V00-2225-026	2/E1	CONTATTO FEMMINA TORNITO SEZIONE FILO: 1	$\frac{8}{8}$				
		- V00-2225-046	2/E1	ADATTATORE PER CONNETTORI - MATERIALE PA	$\frac{1}{1}$				
	X2.P	V00-2225-049	4/D4	CONNETTORE - Nø 14 POLI - MASCHIO SIZE 1	$\frac{1}{1}$	CONNETTORE INTERFACCIA MOTORE			
C		- V00-2225-002	4/D4	CONTATTO MASCHIO TORNITO SEZIONE FILO: 1	$\frac{14}{14}$			C	
		- V00-2225-005	4/D4	RONDELLA PER CONNETTORI HD 34 - DEUTSCH	$\frac{1}{1}$				
		- V00-2225-007	4/D4	DADO PER CONNETTORI HD 34 - DEUTSCH : 11	$\frac{1}{1}$				
D	X2.S	V00-2225-020	4/D4	CONNETTORE - Nø 14 POLI - FEMMINA SIZE 1	$\frac{1}{1}$	CONNETTORE INTERFACCIA MOTORE		D	
		- V00-2225-010	4/D4	CONTATTO FEMMINA TORNITO SEZIONE FILO: 1	$\frac{14}{14}$				
		- V00-2225-046	4/D4	ADATTATORE PER CONNETTORI - MATERIALE PA	$\frac{1}{1}$				
	X4.P	V00-2227-001	4/D6	CONNETTORE - Nø 2 POLI - M - MTA : 44101	$\frac{1}{1}$	CONNETTORE SIRENA			
E	X4.S	V00-2227-021	4/D6	CONNETTORE PORTAFEMMINA - Nø 2 POLI - MO	$\frac{1}{1}$	CONNETTORE SIRENA		E	
	X5.P	V00-2225-027	2/D7	CONNETTORE - Nø 2 POLI - MASCHIO GRIGIO	$\frac{1}{1}$	CONNETTORE ATTUATORE LINEARE			
		- V00-2225-002	2/D7	CONTATTO MASCHIO TORNITO SEZIONE FILO: 1	$\frac{2}{2}$				
F		- V00-2225-028	2/D7	BLOCCACONTATTI MASCHIO VERDE - Nø 2 POLI	$\frac{1}{1}$			F	
		The design and drawings are property of Tesmec SpA, copying and unauthorized disclosure are forbidden.		Electric scheme		COMPONENT LIST		Drawn: Patani	
Grassobbio BG via Zanica, 17/a - Italy - Email: info@tesmec.it tel: +39 035 4232911 fax: +39 035 4522445 Sede di Endine Gaiano BG via Pertegalli - Italy - tel: +39 035 825024 fax: +39 035 826375						Design : AFS 404 600		Drawing Nr. S01-00010 Archive Nr. S01	
						Checked : Ing. Oscar		Date: 11/01/2011	
								Sheet 32 of 38 Following 33	

	1	2	3	4	5	6	7	8
	Sigla	Codice	Pos.	Descrizione da Archivio Materiali	Qto Tot	Funzione Componente	Function Component	
A	X5.S	V00-2225-012	2/D7	CONNETTORE - Nø 2 POLI - FEMMINA GRIGIO	1 1	CONNETTORE ATTUATORE LINEARE		A
	- V00-2225-010	2/D7	CONTATTO FEMMINA TORNITO SEZIONE FILO: 1	2 2				
	- V00-2225-013	2/D7	BLOCCACONTATTI FEMMINE ARANCIO - DEUTSCH	1 1				
B	X6	V00-8401-063	2/C3	PORTA-FUSIBILI VOLANTE A LAME 1 fusibili 30 A	1 1	PORTAFUSIBILE A LAME VOLANTE		B
	X7	V00-2229-062	2/E1	MORSETTO DI TERRA PASSANTE A MOLLA ZDK 2	1 1	MORSETTIERA 0V		
	- V00-2229-045	2/E1	PIASTRA TERMINALE ZAP/TW ZDK2.5 - 2 - WE	1 1	MORSETTIERA 0V			
	- V00-2229-064	2/E1	MORSETTO DI TERRA PASSANTE A MOLLA ZPE 1	1 1	MORSETTIERA 0V			
C		- V00-2229-042	2/E1	PIASTRA TERMINALE ZAP/TW ZDU10 - WEIDMUL	1 1	MORSETTIERA 0V		C
	X8	V00-2229-041	2/B1	MORSETTO PASSANTE A MOLLA ZDU 10 SEZIONE	1 1	MORSETTIERA +12V		
	- V00-2229-042	2/B1	PIASTRA TERMINALE ZAP/TW ZDU10 - WEIDMUL	1 1	MORSETTIERA +12V			
D	X9	V00-2229-044	2/B4	MORSETTO PASSANTE A MOLLA ZDK 2.5 SEZION	1 1	MORSETTIERA LINEA +5 AUX		D
	- V00-2229-045	2/B4	PIASTRA TERMINALE ZAP/TW ZDK2.5 - 2 - WE	1 1	MORSETTIERA LINEA +5 AUX			
	X10	V00-2229-044	2/A4	MORSETTO PASSANTE A MOLLA ZDK 2.5 SEZION	1 1	MORSETTIERA LINEA +6 ELETTROVALVOLE		
	- V00-2229-045	2/A4	PIASTRA TERMINALE ZAP/TW ZDK2.5 - 2 - WE	1 1	MORSETTIERA LINEA +6 ELETTROVALVOLE			
E		- V00-2229-045	2/A4	PIASTRA TERMINALE ZAP/TW ZDK2.5 - 2 - WE	1 1	MORSETTIERA LINEA +8 ACCELERATORE		E
	X.A.P	V00-2225-001	9/C1	CONNETTORE - Nø 40 POLI - MASCHIO FISSAG	1 1			
	- V00-2225-002	9/C1	CONTATTO MASCHIO TORNITO SEZIONE FILO: 1	40 40				
F	X.A.S	V00-2225-009	9/C1	CONNETTORE - Nø 40 POLI - FEMMINA SIZE 1	1 1			F



The design and drawings are property of Tesmec SpA, copying and unauthorized disclosure are forbidden

Electric scheme

COMPONENT LIST

Drawn: Patani

Drawing Nr. S01-00010  
Archive Nr. S01

Sheet 33 of 38

Grassobbio BG via Zanica, 17/a - Italy - Email: info@tesmec.it tel: +39 035 4232911 fax: +39 035 4522445  
Sede di Endine Gaiano BG via Pertegalli - Italy - tel: +39 035 825024 fax: +39 035 826375

Design : AFS 404 600

Checked : Ing. Oscar

Date: 11/01/2011

Following 34

1

2

3

4

5

6

7

8

1	2	3	4	5	6	7	8
Sigla	Codice	Pos.	Descrizione da Archivio Materiali	Qta Tot	Funzione Componente	Function Component	
A	- V00-2225-010	9/C1	CONTATTO FEMMINA TORNITO SEZIONE FILO: 1	40 40			A
	- V00-2225-011	9/C1	COPERTURA POSTERIORE - DEUTSCH : DRC 40-	1 1			
XAc.F	V00-2227-058	8/D4	CONNETTORE MSTB 2.5/2-ST5-5.08 - Nø 2 PO	1 1	CONNETTORE IMPOSTAZIONE SCHEDA		
XCP.F	V00-2225-014	2/D5	CONNETTORE - Nø 6 POLI - FEMMINA GRIGIO	1 1	CONNETTORE CONTROLLO PRERISCALDO		
	- V00-2225-010	2/D5	CONTATTO FEMMINA TORNITO SEZIONE FILO: 1	6 6			
	- V00-2225-015	2/D5	BLOCCACONTATTI FEMMINA ARANCIONE - Nø 6	1 1			
XF	V00-2229-038	2/B2	MORSETTO PORTAFUSIBILE A LAME ZSI 6-2/FC	10 10	MORSETTO PORTAFUSIBILE A LAME		
-XP1	V00-2227-030	19/C8	PRESA ACCENDISIGARI VOLANTE	1 1	ACCENDISIGARI		C
XPc.F	V00-2227-021	8/D4	CONNETTORE PORTAFEMMINA - Nø 2 POLI - MO	1 1	CONNETTORE ALIMENTAZIONE PC		
XRP1.F	V00-2227-022	6/C4	CONNETTORE PORTAFEMMINA - Nø 3 POLI - MO	1 1	CONNETTORE PORTAFEMMINA POTENZIOMETRO		
XRP1.M	V00-2227-023	6/C4	CONNETTORE PORTAMASCHIO - Nø 3 POLI - MO	1 1	CONNETTORE PORTAMASCHIO POTENZIOMETRO		
XRP2.F	V00-2227-022	6/C5	CONNETTORE PORTAFEMMINA - Nø 3 POLI - MO	1 1	CONNETTORE PORTAFEMMINA POTENZIOMETRO JOYSTICK		D
XRP2.M	V00-2227-023	6/C5	CONNETTORE PORTAMASCHIO - Nø 3 POLI - MO	1 1	CONNETTORE PORTAMASCHIO POTENZIOMETRO JOYSTICK		
XTC	V00-2232-012	13/B2	TAPPO DI CHIUSURA M12 X MULTIPRESE - MUR	1 1	TAPPO COPRIFORO		
-Y1	99999999	11/E2	IDRAULIC.PART.....(CODICE IDRAULICO)	1 1	ELETTRORVALVOLA COMANDO POMPA		E
-Y2	99999999	11/E3	IDRAULIC.PART.....(CODICE IDRAULICO)	1 1	ELETTRORVALVOLA REGOLAZIONE TIRO CABESTANO		
-Y3	99999999	9/E3	IDRAULIC.PART.....(CODICE IDRAULICO)	1 1	ELETTRORVALVOLA FRENO NEGATIVO CABESTANO		
-Y4	99999999	9/E3	IDRAULIC.PART.....(CODICE IDRAULICO)	1 1	ELETTRORVALVOLA COMANDO RIAVVOLGITORE		



The design and drawings are property of Tesmec SpA, copying and unauthorized disclosure are forbidden

Electric scheme

COMPONENT LIST

Drawn: Patani

Drawing Nr. S01-00010  
Archive Nr. S01

Sheet 34 of 38

Grassobbio BG via Zanica, 17/a - Italy - Email: info@tesmec.it tel: +39 035 4232911 fax: +39 035 4522445  
Sede di Endine Galiano BG via Pertegalli - Italy - tel: +39 035 825024 fax: +39 035 826375

Design : AFS 404 600

Checked : Ing. Oscar

Date: 11/01/2011

Following 35

1

2

3

4

5

6

7

8

1	2		3	4	5	6	7	8	
Sigla	Codice	Pos.	Descrizione da Archivio Materiali	Qta Tot	Funzione Componente	Function Component			
A	-Y5	99999999	9/E4	IDRAULIC.PART.....(CODICE IDRAULICO)	1 1	ELETTROVALVOLA VENTOLA RADIATORE OLIO IDRAULICO	A		
	-Y6	99999999	9/E6	IDRAULIC.PART.....(CODICE IDRAULICO)	1 1	ELETTROVALVOLA CILINDRO STABILIZZATORE			
	-Y7	99999999	9/E7	IDRAULIC.PART.....(CODICE IDRAULICO)	1 1	ELETTROVALVOLA CILINDRO BLOCCAFUNE [OPT 071]			
B	-Y8	99999999	10/E2	IDRAULIC.PART.....(CODICE IDRAULICO)	1 1	ELETTROVALVOLA PRESSA	B		
	YV1	V00-2232-015	13/D2	MULTICONNETTORE CON CAVO FISSO - 8 X M12	1 1	PRESA IN METALLO X 8 ELETTROVALVOLE			
	YV2	V00-2232-014	13/D4	MULTICONNETTORE CON CAVO FISSO - PIN TO	1 1	PRESA IN METALLO X 4 ELETTROVALVOLE "PIN TO PIN"			
	YV3	V00-2232-014	13/D7	MULTICONNETTORE CON CAVO FISSO - PIN TO	1 1	PRESA IN METALLO X 4 ELETTROVALVOLE "PIN TO PIN"			
C	C								
D	D								
E	E								
F	F								



The design and drawings are property of Tesmec SpA, copying and unauthorized disclosure are forbidden

Electric scheme

COMPONENT LIST

Drawn: Patani

Drawing Nr. S01-00010  
Archive Nr. S01

Sheet 35 of 38

Grassobbio BG via Zanica, 17/a - Italy - Email: info@tesmec.it tel: +39 035 4232911 fax: +39 035 4522445  
Sede di Endine Galiano BG via Pertegalli - Italy - tel: +39 035 825024 fax: +39 035 826375


Design : AFS 404 600

Checked : Ing. Oscar

Date: 11/01/2011


Following 36

1	2		3		4		5		6		7		8	
DISTINTA MATERIALI					DISTINTA MATERIALI									
Codice	Nuova codifica	Descrizione da Archivio Materiali		Qtà tot.	U.M.	Codice	Nuova codifica	Descrizione da Archivio Materiali		Qtà tot.	U.M.			
00000000		ENGINE.PART.....(CODICI MOTORE)		5	N	- V00-2225-011		COPERTURA POSTERIORE - DEUTSCH : DRC 40-		1	N			
99999999		IDRAULIC.PART.....(CODICE IDRAULICO)		13	N	V00-2225-012		CONNETTORE - Nø 2 POLI - FEMMINA GRIGIO		1	N			
V00-1500-003		BATTERIA 100 AH 12 V - EN 760 A - LUNGH.		1	N	- V00-2225-010		CONTATTO FEMMINA TORNITO SEZIONE FILO: 1		2	N			
- V00-2229-003		MORSETTO BATTERIA POLO POSITIVO CAVO SEZ		1	N	- V00-2225-013		BLOCCACONTATTI FEMMINE ARANCIO - DEUTSCH		1	N			
- V00-2229-004		COPRIMORSETTO POLO POSITIVO BATTERIA ROS		1	N	V00-2225-014		CONNETTORE - Nø 6 POLI - FEMMINA GRIGIO		1	N			
- V00-2229-005		MORSETTO BATTERIA POLO NEGATIVO CAVO SEZ		1	N	- V00-2225-010		CONTATTO FEMMINA TORNITO SEZIONE FILO: 1		6	N			
- V00-2229-006		COPRIMORSETTO POLO NEGATIVO BATTERIA NER		1	N	- V00-2225-015		BLOCCACONTATTI FEMMINA ARANCIONE - Nø 6		1	N			
V00-2200-017		LAMPADA BA 9S 12 V 3 W - OSRAM : 3894		6	N	V00-2225-020		CONNETTORE - Nø 14 POLI - FEMMINA SIZE 1		1	N			
V00-2200-029		LAMPADA ROTANTE 9/32 V - XENON REVOLUX :		1	N	- V00-2225-010		CONTATTO FEMMINA TORNITO SEZIONE FILO: 1		14	N			
- V00-2200-030		SUPPORTO TUBOLARE - XENON : 35.001.520		1	N	- V00-2225-046		ADATTATORE PER CONNETTORI - MATERIALE PA		1	N			
V00-2225-001		CONNETTORE - Nø 40 POLI - MASCHIO FISSAG		1	N	V00-2225-025		CONNETTORE - Nø 8 POLI - FEMMINA SIZE 12		1	N			
- V00-2225-002		CONTATTO MASCHIO TORNITO SEZIONE FILO: 1		40	N	- V00-2225-026		CONTATTO FEMMINA TORNITO SEZIONE FILO: 1		8	N			
V00-2225-003		CONNETTORE - Nø 8 POLI - MASCHIO SIZE 12		1	N	- V00-2225-046		ADATTATORE PER CONNETTORI - MATERIALE PA		1	N			
- V00-2225-004		CONTATTO MASCHIO TORNITO SEZIONE FILO: 1		8	N	V00-2225-027		CONNETTORE - Nø 2 POLI - MASCHIO GRIGIO		1	N			
- V00-2225-005		RONDELLA PER CONNETTORI HD 34 - DEUTSCH		1	N	- V00-2225-002		CONTATTO MASCHIO TORNITO SEZIONE FILO: 1		2	N			
- V00-2225-007		DADO PER CONNETTORI HD 34 - DEUTSCH : 11		1	N	- V00-2225-028		BLOCCACONTATTI MASCHIO VERDE - Nø 2 POLI		1	N			
V00-2225-006		CONNETTORE - Nø 14 POLI - MASCHIO SIZE 1		1	N	V00-2227-001		CONNETTORE - Nø 2 POLI - M - MTA : 44101		1	N			
- V00-2225-002		CONTATTO MASCHIO TORNITO SEZIONE FILO: 1		14	N	V00-2227-021		CONNETTORE PORTAFEMMINA - Nø 2 POLI - MO		2	N			
- V00-2225-005		RONDELLA PER CONNETTORI HD 34 - DEUTSCH		1	N	V00-2227-022		CONNETTORE PORTAFEMMINA - Nø 3 POLI - MO		2	N			
- V00-2225-007		DADO PER CONNETTORI HD 34 - DEUTSCH : 11		1	N	V00-2227-023		CONNETTORE PORTAMASCHIO - Nø 3 POLI - MO		2	N			
V00-2225-009		CONNETTORE - Nø 40 POLI - FEMMINA SIZE 1		1	N	V00-2227-030		PRESA ACCENDISIGARI VOLANTE		1	N			
- V00-2225-010		CONTATTO FEMMINA TORNITO SEZIONE FILO: 1		40	N	V00-2227-058		CONNETTORE MSTB 2.5/2-ST5-5.08 - Nø 2 PO		1	N			


	The design and drawings are property of Tesmec SpA, copying and unauthorized disclosure are forbidden.	Electric scheme	MATERIAL LIST		Drawn: Patani	Drawing Nr. S01-00010 Archive Nr. S01	Sheet 36 of 38
			Design : AFS 404 600	Checked : Ing. Oscar	Date: 11/01/2011	Following 37	

Grassano BG via Zanica, 17/a - Italy - Email: info@tesmec.it tel: +39 035 4232911 fax: +39 035 4522445  
 Sede di Endine Galiano BG via Pertegalli - Italy - tel: +39 035 825024 fax: +39 035 826375

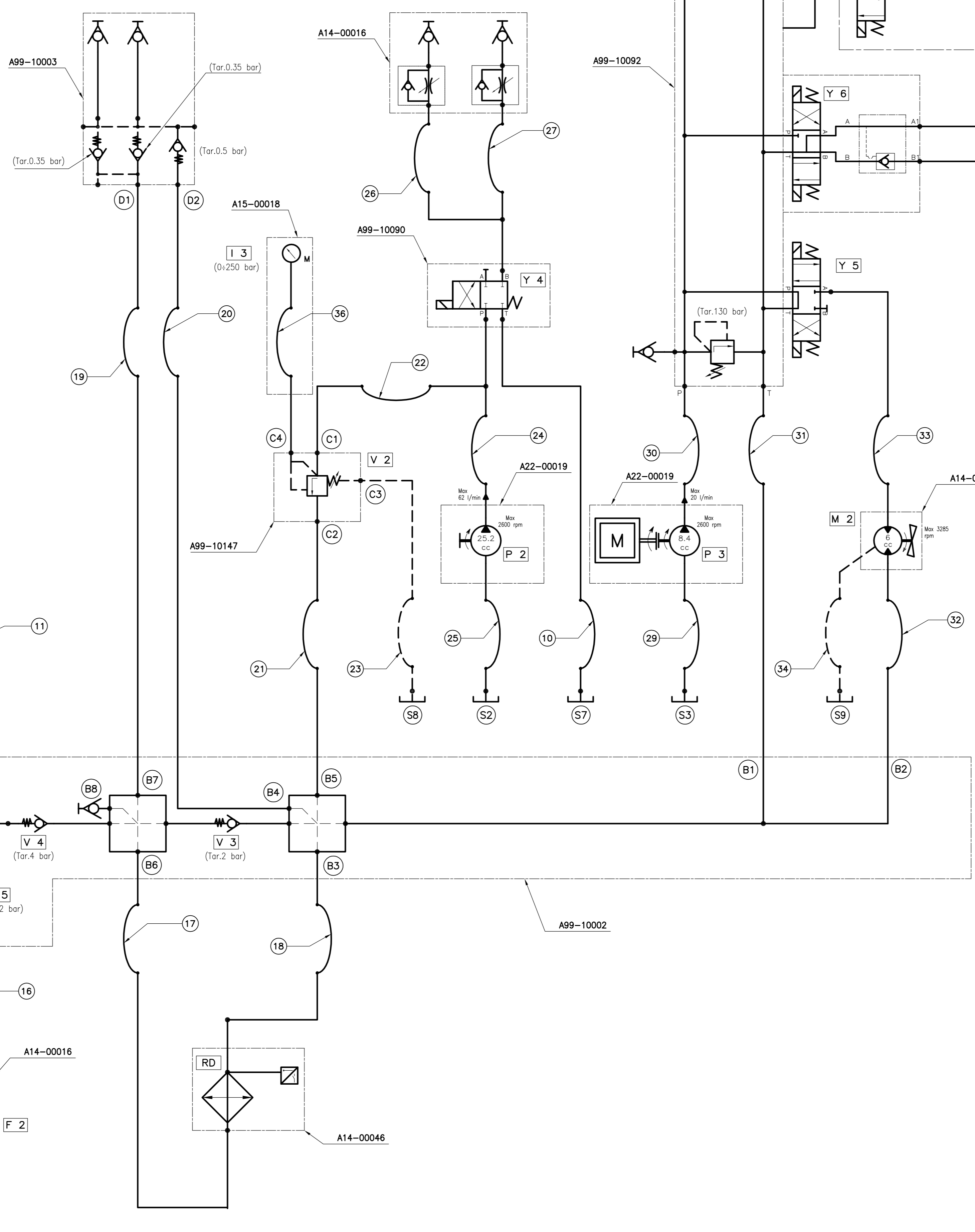
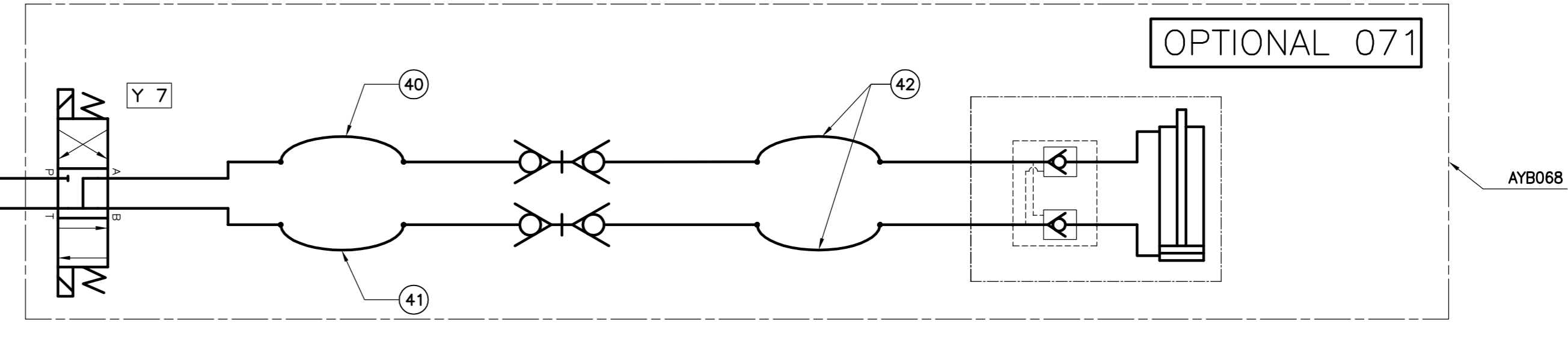
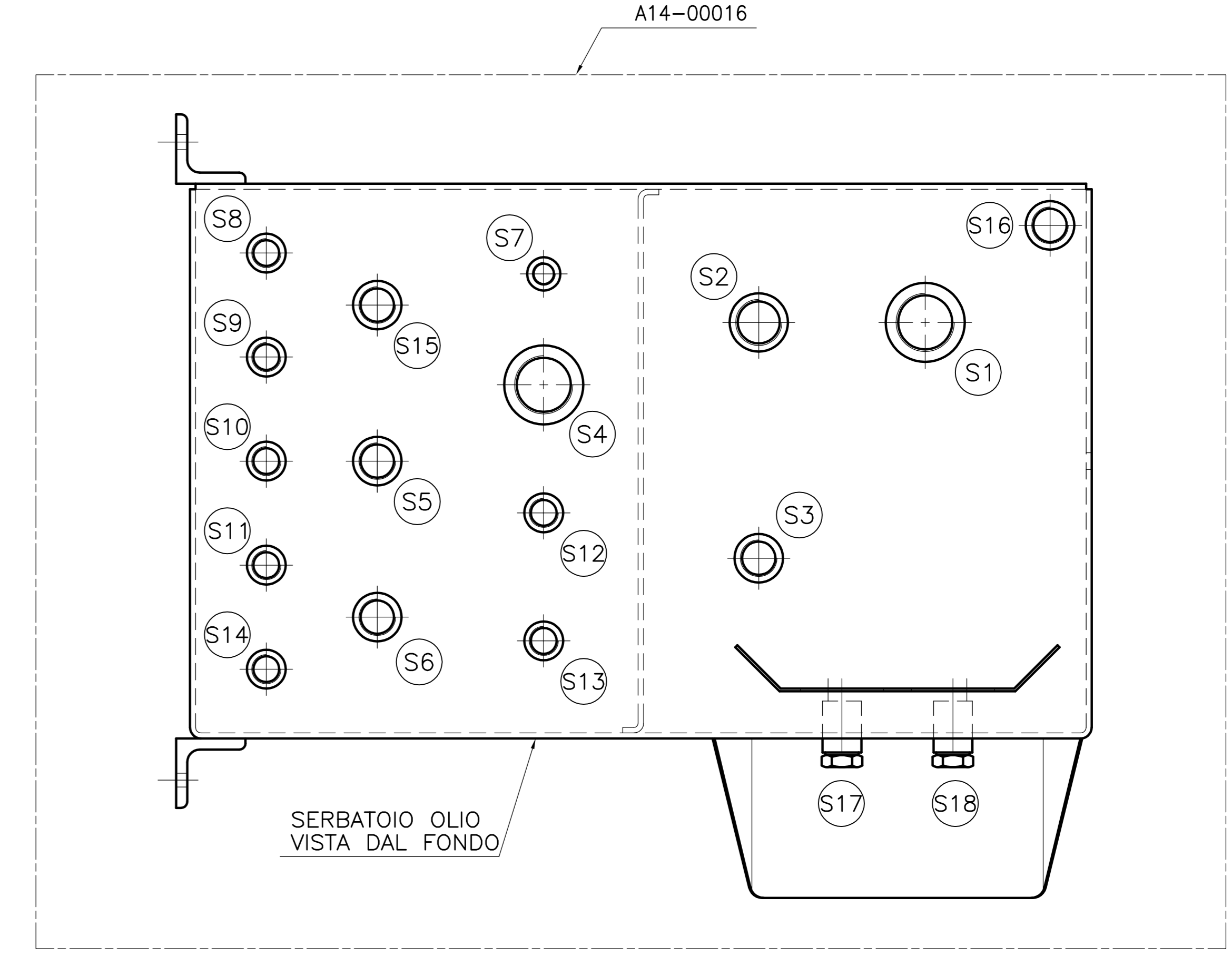
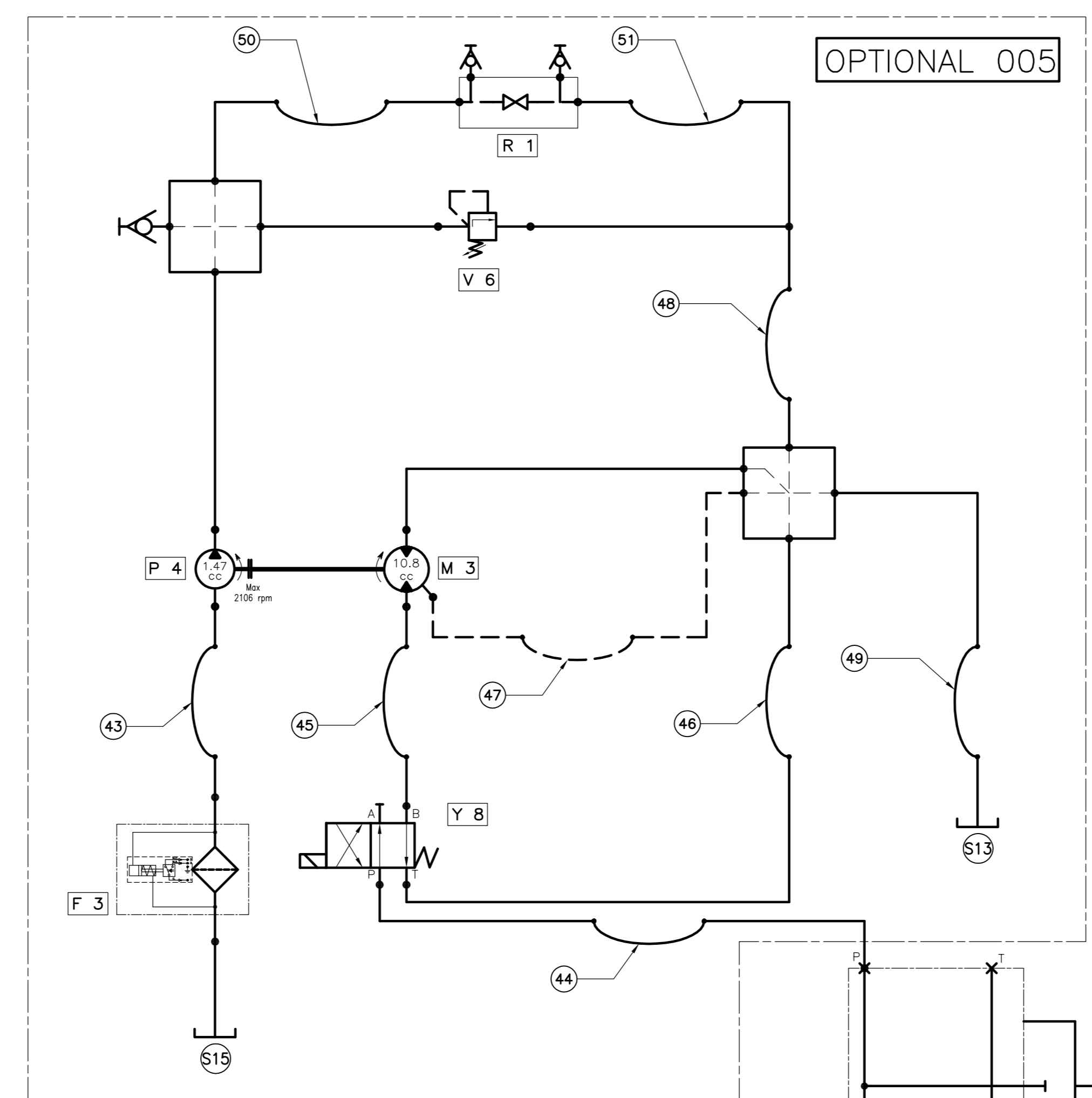
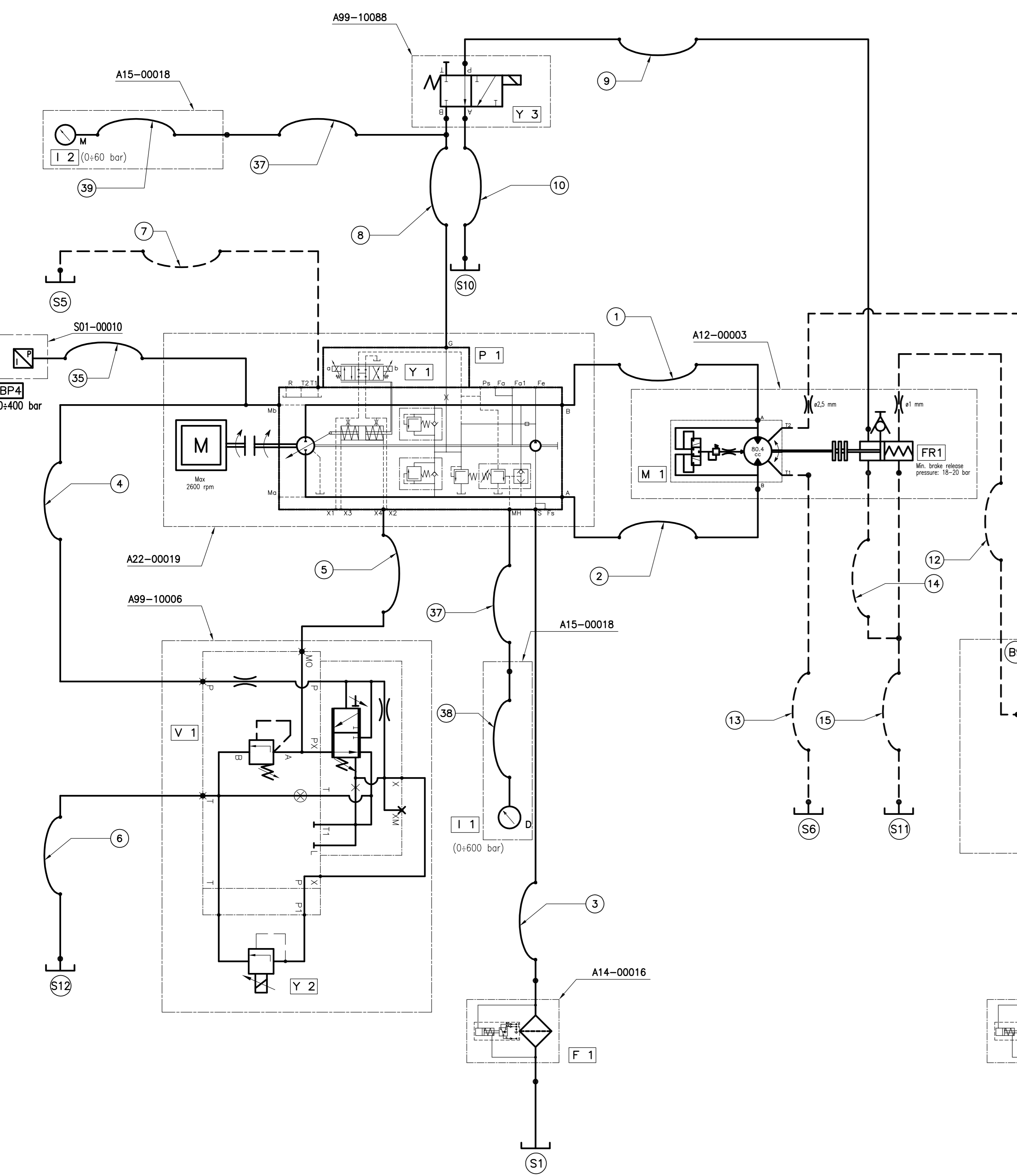
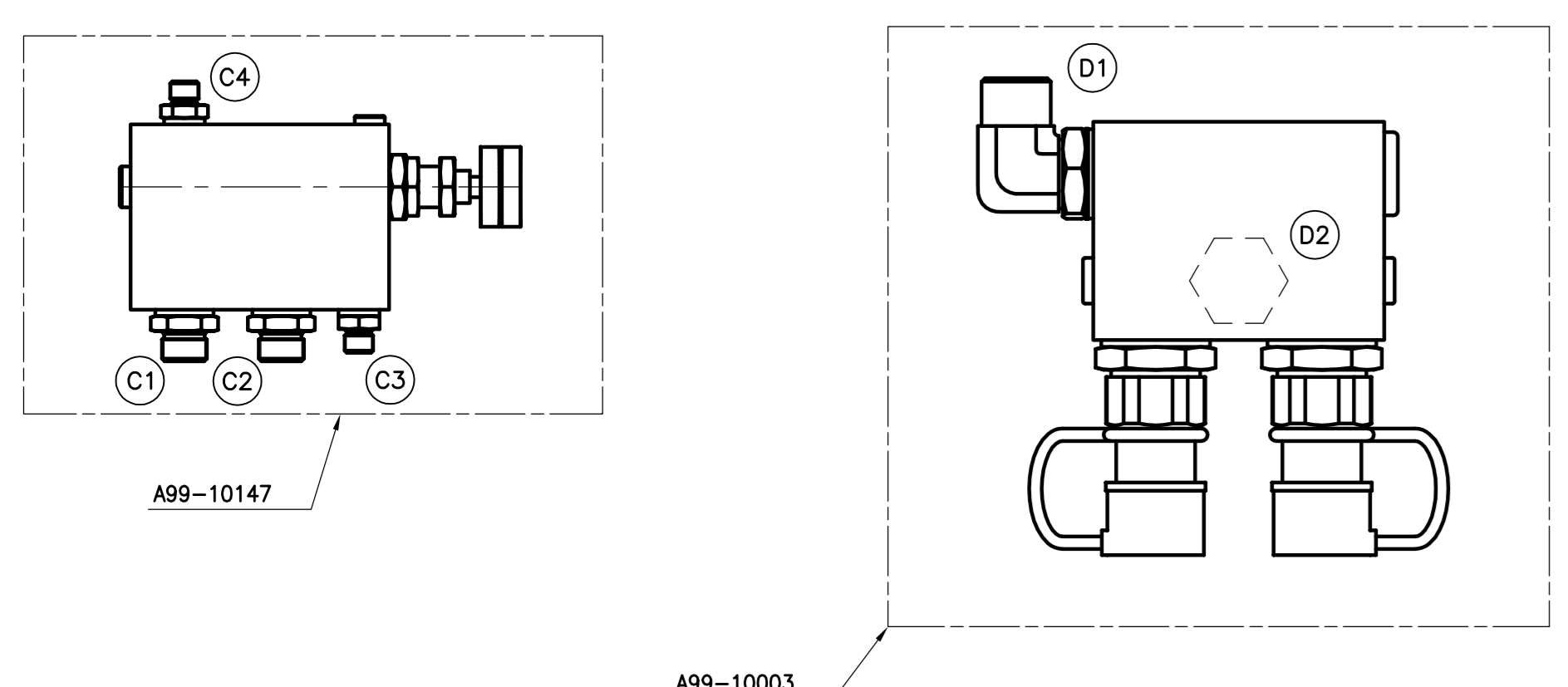
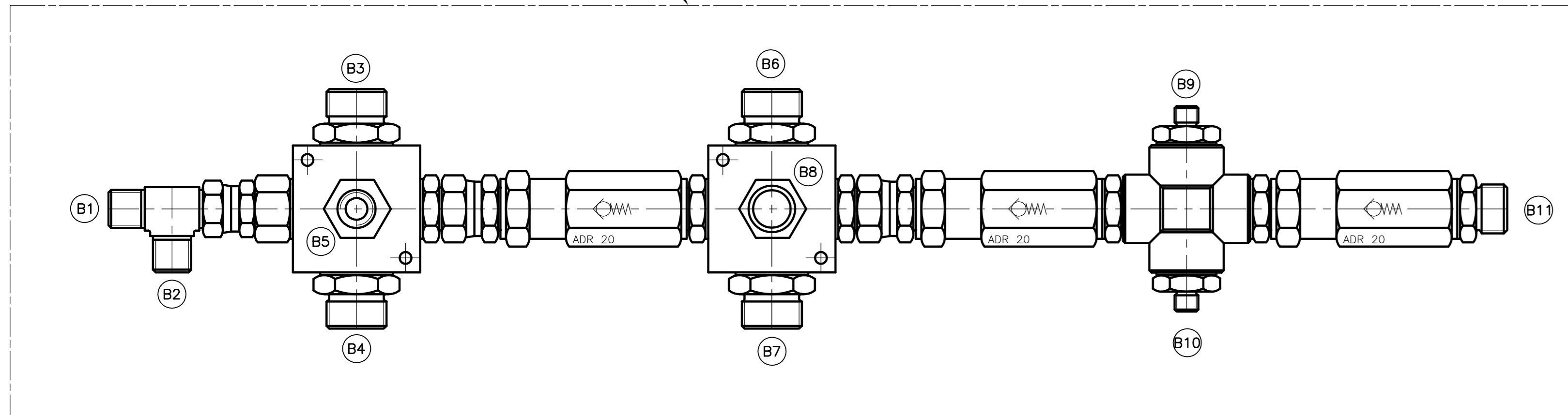
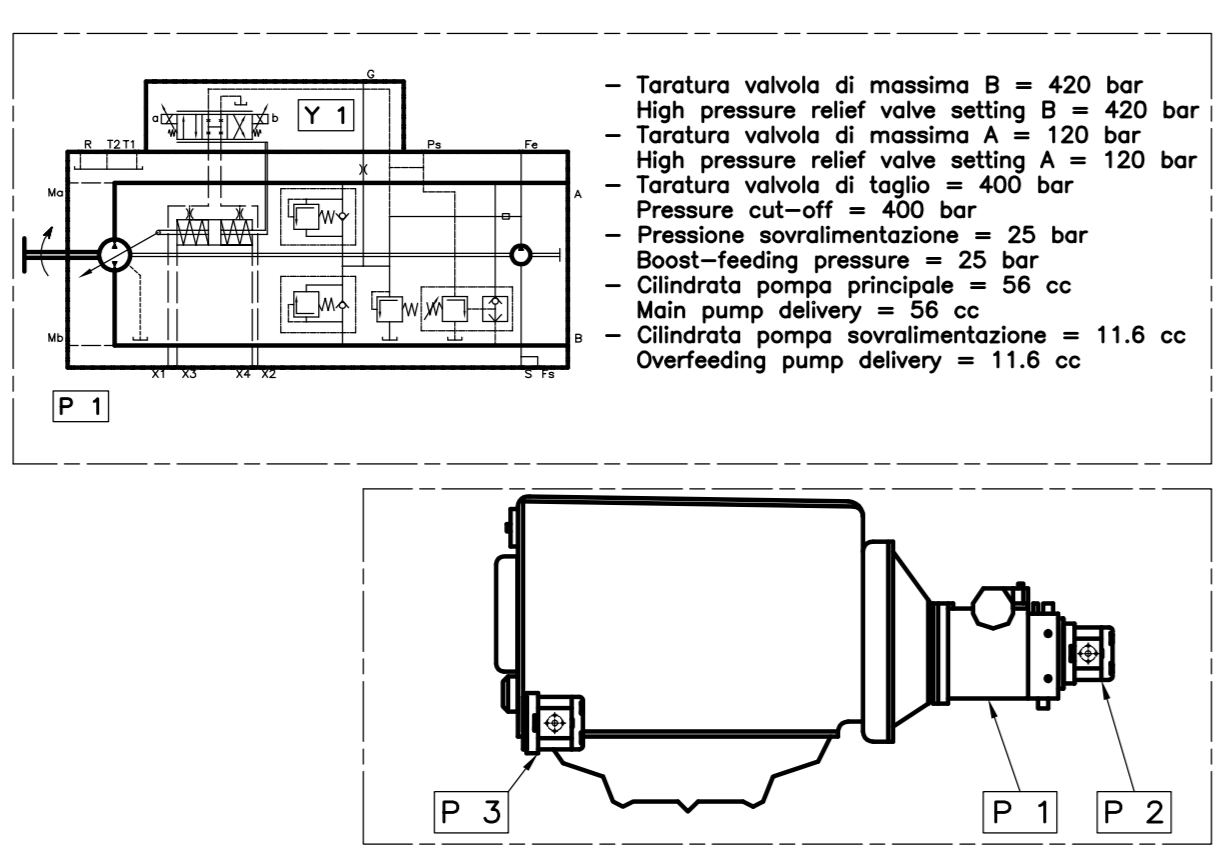
1	2		3		4		5		6		7		8	
DISTINTA MATERIALI					DISTINTA MATERIALI									
Codice	Nuova codifica	Descrizione da Archivio Materiali		Qtà tot.	U.M.	Codice	Nuova codifica	Descrizione da Archivio Materiali		Qtà tot.	U.M.			
V00-2227-061		CONNETTORE - Nø 5 + PE POLI - FEMMINA FI		2	N	V00-8400-022		DIODO A LED - ROSSO 12 V DC - 8 MM - IP		6	N			
V00-2227-062		CONNETTORE - Nø 5 + PE POLI - MASCHIO VO		2	N	V00-8400-023		DIODO A LED - GIALLO 12 V DC - 8 MM - IP		4	N			
V00-2229-038		MORSETTO PORTAFUSIBILE A LAME ZSI 6-2/FC		10	N	V00-8400-034		RESISTENZA 120 OHM 1/4 W - RS : 135-780		3	N			
V00-2229-039		PIASTRA TERMINALE ZAP ZDU6-2 SW - WEIDMU		2	N	V00-8401-011		FUSIBILE A LAME 3 A VIOLETTO INTERASSE L		3	N			
V00-2229-041		MORSETTO PASSANTE A MOLLA ZDU 10 SEZIONE		1	N	V00-8401-015		CHIAVE AVVIAMENTO MOTORE - COBO : 14.134		1	N			
V00-2229-042		PIASTRA TERMINALE ZAP/TW ZDU10 - WEIDMUL		2	N	V00-8401-020		FUSIBILE A LAME 10 A ROSSO INTERASSE LAM		1	N			
V00-2229-044		MORSETTO PASSANTE A MOLLA ZDK 2.5 SEZION		3	N	V00-8401-036		FUSIBILE A LAME 5 A BEIGE INTERASSE LAME		2	N			
V00-2229-045		PIASTRA TERMINALE ZAP/TW ZDK2.5 - 2 - WE		4	N	V00-8401-037		FUSIBILE A LAME 7.5 A MARRONE INTERASSE		2	N			
V00-2229-062		MORSETTO DI TERRA PASSANTE A MOLLA ZDK 2		1	N	V00-8401-038		INTERRUTTORE STACCABATTERIA 12-24 V - 25		1	N			
V00-2229-064		MORSETTO DI TERRA PASSANTE A MOLLA ZPE 1		1	N	- V00-8401-039		CHIAVE PER INTERRUTTORE STACCABATTERIA :		1	N			
V00-2232-002		CAVO M12 DIRITTO - L. 2 M - A Y - 3+3 FI		5	N	V00-8401-042		AVVISATORE ACUSTICO 12 V 129 DB - IP 54		1	N			
V00-2232-003		CAVO M12 DIRITTO - L. 2 M - A Y PIN TO P		1	N	V00-8401-054		FUSIBILE A LAME 1 A NERO INTERASSE LAME		2	N			
V00-2232-005		CAVO M12 DIRITTO - L. 5 M - 4 FILI + SCH		1	N	V00-8401-063		PORTA-FUSIBILI VOLANTE A LAME 1 fusibili 30 A		1	N			
V00-2232-006		CAVO M12 DIRITTO - L. 2 M - A Y - 2 CONN		1	N	V00-8401-064		FUSIBILE A LAME 80 A TRASPARENTE INTERAS		1	N			
V00-2232-012		TAPPO DI CHIUSURA M12 X MULTIPRESE - MUR		7	N	V00-8402-001		RELE 12 V 1 NO - 80 A - BOSCH : 03330060		1	N			
V00-2232-014		MULTICONNETTORE CON CAVO FISSO - PIN TO		2	N	V00-8402-014		RELE 12 V 2 SC - 8 A - FINDER : 46.52.9.		16	N			
V00-2232-015		MULTICONNETTORE CON CAVO FISSO - 8 X M12		1	N	- V00-8402-020		MODULO DIODO + LED 6-24 V DC/AC - FINDER		15	N			
V00-2232-019		CAVO M12 DIRITTO - L. 5 M - 4 FILI PVC -		1	N	- V00-8402-039		ZOCOLO RELE 2SC MORSETTO A MOLLA MONTAG		16	N			
V00-2232-053		CAVO M12 DIRITTO - L. 1 M - A Y - 2 CONN		3	N	- V00-8402-040		MODULO TEMPORIZZATORE 12-24 V DC/AC - FI		1	N			
V00-2232-059		CAVO M12 DIRITTO - L. 1 M - CONNETTORE		1	N	V00-8410-001		PULSANTE EMERGENZA - D. FUNGO: 40 ROSSO		1	N			
V00-8400-011		DIODO 1N4007		2	N	- V00-8410-003		TARGHETTA STOP - D 22 - D. TARGHETTA 59		1	N			
V00-8400-018		MODULO PORTACOMPONENTI 5 - WEIDMULLER :		1	N	V00-8410-002		CONTATTO NA/NC - CEMA : P9B11VN		1	N			

	The design and drawings are property of Tesmec SpA, copying and unauthorized disclosure are forbidden.	Electric scheme	MATERIAL LIST		Drawn: Patani	Drawing Nr. S01-00010 Archive Nr. S01	Sheet 37 of 38
			Design : AFS 404 600	Checked : Ing. Oscar	Date: 11/01/2011	Following 38	

Grassobio BG via Zanica, 17/a - Italy - Email: info@tesmec.it tel: +39 035 4232911 fax: +39 035 4522445  
Sede di Endine Galiano BG via Pertegalli - Italy - tel: +39 035 825024 fax: +39 035 826375

1	2		3	4		5	6	7	8			
A	DISTINTA MATERIALI					DISTINTA MATERIALI						
	Codice	Nuova codifica	Descrizione da Archivio Materiali	Qtà tot.	U.M.	Codice	Nuova codifica	Descrizione da Archivio Materiali	Qtà tot.	U.M.		
	V00-8410-004		CONTATTO NC - CEMA : P9B01VN	1	N	V00-8600-008		DISPLAY GRAFICO 9 - 32 V - DSF : J1939 E	1	N		
		V00-8410-005		ALIMENTAZIONE - CEMA : P9PDNV0	6	N	- V00-2225-045		CONNETTORE + PIN X ENGIMETER - DSF : DT0	1	N	
B			V00-8410-006		CONTATTO NA - CEMA : P9B10VN	11	N					
			V00-8410-008		SELETTORE A LEVA LUNGA - Nø 2 POS.FISSE	1	N					
			V00-8410-009		SELETTORE A LEVA LUNGA - Nø 2 POS.FISSE	1	N					
			V00-8410-011		MANIPOLATORE Nø 3 POS. TEMPORANEE NERO -	2	N					
			V00-8410-015		SELETTORE A LEVA LUNGA - Nø 2 POS.FISSE	3	N					
			V00-8410-021		SELETTORE A LEVA LUNGA - Nø 3 POS. CON R	1	N					
C			V00-8430-001		SELETTORE AVVIAMENTO A FREDDO - Nø 2 POS	1	N					
			V00-8430-006		PULSANTE ROTONDO D. 16 NERO - IP 67	1	N					
			V00-8500-016		POTENZIOMETRO ROTATIVO - Nø 3 GIRI 5 KOH	1	N					
D			- V00-8500-012		MANOPOLA GRADUATA POTENZIOMETRO D. 46 -	1	N					
			V00-8500-018		ATTUATORE LINEARE LA1 12 V - 5.8 A - FOR	1	N					
			V00-8500-025		SCHEDA CONTROLLO TIRO AF3-CV - ELTON : 3	1	N					
			- V00-2227-046		CONNETTORE MSTB 2.5/24-ST5-5.08 - Nø 24	2	N					
			V00-8500-027		MANIPOLATORE SEMPLICE - KIEPE : STO11B9P	1	N					
			V00-8500-041		SCHEDA CONTROLLO VELOCITA CON INTERFACCI	1	N					
E			V00-8510-033		ENCODER ASSOLUTO - D.ALBERO 8 MM - FLANG	1	N					
			V00-8510-036		FINECORSO A PULSANTE CON ROTELLA - CONTA	2	N					
			V00-8510-057		TRASMETTITORE TEMPERATURA 12 / 24 V - FA	1	N					
			V00-8510-072		TRASDUTTORE PRESSIONE 0-400 BAR - 8-24 V	1	N					
		V00-8510-074		GALLEGGIANTE A LEVA REGOLABILE - L. 110ö	1	N						
F			The design and drawings are property of Tesmec SpA, copying and unauthorized disclosure are forbidden		Electric scheme		MATERIAL LIST		Drawn: Patani Drawing Nr. S01-00010 Archive Nr. S01		Sheet 38 of 38	
	Grassobio BG via Zanica, 17/a - Italy - Email: info@tesmec.it tel: +39 035 4232911 fax: +39 035 4522445 Sede di Endine Galiano BG via Pertegalli - Italy - tel: +39 035 825024 fax: +39 035 826375						Design : AFS 404 600		Checked : Ing. Oscar Date: 11/01/2011		Following	

F 1	V00-6600-010	Filtro completo	1 Pz.
	V00-6600-011	Hydraulic filter	1 Pz.
	V00-6600-024	Disposabile filter	1 Pz.
F 2	V00-8510-008	Intasatore	1 Pz.
	V00-8510-039	Clogging filter	1 Pz.



51	TUBO FLEX - R1	6x	- x 1/4" GAS - y 1/4" GAS	1
50	TUBO FLEX - 352-04 x	-	- x 1/4" GAS - y 1/4" GAS 700 BAR	1
49	TUBO FLEX - R1	13x	- x 1/2" GAS - y 1/2" GAS	1
48	TUBO FLEX - R1	6x	- x 1/4" GAS - y 1/4" GAS	1
47	TUBO FLEX - R1	6x	- x 1/4" GAS - y 1/4" GAS	1
46	TUBO FLEX - R1	13x	- x 1/2" GAS - y 1/2" GAS	1
45	TUBO FLEX - R2	13x	- x 1/2" GAS - y 1/2" GAS	1
44	TUBO FLEX - R2	13x	- x 1/2" GAS - y 1/2" GAS	1
43	TUBO FLEX - R1	19x	- x 3/4" GAS - y 3/4" GAS	1

OPTIONAL 005

42	05301380	TUBO R2	6x 800 K1/4 A1/4 + GUAINA	2
41	05301983	TUBO R2	6x 450 K1/4 K(45)/4 L=90"	1
40	05301982	TUBO R2	6x 400 K1/4 K(45)/4 L=90"	1

OPTIONAL 071

39	07-000-002	TUBO MCS	6400 - 50.204 - 60.204 - 1000	1
38	07-000-003	TUBO MCS	6400 - 50.208 - 60.204 - 1000	1
37	07-000-004	TUBO MCS	6400 - 60.204 - 60.204 - 2500	2
36	07-000-001	TUBO MCS	6400 - 50.204 - 60.204 - 500	1
35	04-104-005	TUBO FLEX - 45P	6 x 400 - A 1/4" GAS - A 1/4" GAS CALZA TELATA	1
34	01-004-002	TUBO FLEX - R1	6x1000 - K 1/4" GAS - K 1/4" GAS - L197"	1
33	02-006-001	TUBO FLEX - R2	10x2600 - A 3/8" GAS - K 3/8" GAS	1
32	01-008-027	TUBO FLEX - R1	13x1300 - A 1/2" GAS - K 1/2" GAS	1
31	01-008-028	TUBO FLEX - R1	13x1350 - K 1/2" GAS - K 1/2" GAS - L180"	1
30	02-008-014	TUBO FLEX - R2	13x1000 - K 1/2" GAS - K 1/2" GAS - L0"	1
29	01-012-016	TUBO FLEX - R1	19x2000 - K 3/4" GAS - K 3/4" GAS - L1180"	1
28	02-004-014	TUBO FLEX - R2	6x850 - K 1/4" GAS - K 1/4" GAS - L0"	2
27	02-008-013	TUBO FLEX - R2	13x2350 - K 1/2" GAS - K 1/2" GAS - L180"	1
26	02-008-012	TUBO FLEX - R2	13x2250 - A 1/2" GAS - K 1/2" GAS	1
25	01-016-016	TUBO FLEX - R1	25x2000 - K 1" GAS - K 1" GAS - L0"	1
24	02-008-011	TUBO FLEX - R2	13x600 - A 1/2" GAS - K 1/2" GAS	1
23	01-004-003	TUBO FLEX - R1	6x1900 - K 1/4" GAS - K 1/4" GAS - L0"	1
22	02-008-010	TUBO FLEX - R2	13x1800 - K 1/2" GAS - K 1/2" GAS - L270"	1
21	01-012-015	TUBO FLEX - R1	19x1700 - K 3/4" GAS - K 3/4" GAS - L270"	1
20	01-016-015	TUBO FLEX - R1	25x1700 - K 1" GAS - K 1" GAS - L0"	1
19	01-016-014	TUBO FLEX - R1	25x1500 - A 1" GAS - K 1" GAS	1
18	01-016-013	TUBO FLEX - R1	25x1000 - A 1" GAS - K 1" GAS	1
17	01-016-012	TUBO FLEX - R1	25x1000 - A 1" GAS - K 1" GAS	1
16	01-012-014	TUBO FLEX - R1	19x750 - K 3/4" GAS - K 3/4" GAS - L180"	1
15	01-008-008	TUBO FLEX - R1	10x1850 - A 3/8" GAS - K 3/8" GAS	1
14	01-004-004	TUBO FLEX - R1	6x300 - K 1/4" GAS - K 1/4" GAS - L90"	1
13	01-012-013	TUBO FLEX - R1	19x2100 - K 3/4" GAS - K 3/4" GAS - L90"	1
12	01-004-008	TUBO FLEX - R1	6x900 - K 1/4" GAS - K 1/4" GAS - L0"	1
11	01-004-009	TUBO FLEX - R1	6x1300 - K 1/4" GAS - K 1/4" GAS - L0"	1
10	01-004-002	TUBO FLEX - R1	6x2000 - A 1/4" GAS - K 1/4" GAS	2
9	01-004-006	TUBO FLEX - R1	6x1900 - K 1/4" GAS - K 1/4" GAS - L0"	1
8	01-004-005	TUBO FLEX - R1	6x650 - A 1/4" GAS - K 1/4" GAS	1
7	01-012-012	TUBO FLEX - R1	19x1900 - K 3/4" GAS - K 3/4" GAS - L90"	1
6	01-008-007	TUBO FLEX - R1	10x1900 - K 3/8" GAS - K 3/8" GAS - L0"	1
5	01-004-004	TUBO FLEX - R1	6x1300 - K 1/4" GAS - K 1/4" GAS - L180"	1
4	04-104-004	TUBO FLEX - 45P	6x1250 - K 1/4" GAS - K 1/4" GAS - L180" CALZA TELATA	1
3	01-020-007	TUBO FLEX - R1	32x2100 - K 1" 1/4 GAS - K 1" 1/4 GAS - L0"	1
2	03-1116-002	TUBO FLEX - 45H	25x1150 - A 1" GAS - K 1" GAS CALZA TELATA	1
1	03-1116-001	TUBO FLEX - 45H	25x800 - A 1" GAS - A 1" GAS CALZA TELATA	1

Y7	V00-6100-071	ROPE LOCKING CYLINDER SOLENOID VALVE CONTROL
OPT	OPTIONAL 071	OPTIONAL 071
Y8	V00-6100-021 + V00-7200-015	COMPRESSOR SOLENOID VALVE CONTROL
V6	V00-6203-016	COMPRESSOR REGULATION VALVE
R1	A99-10115	COMPRESSOR HYDRAULIC OIL DRAIN PLUG VALVE
P4	V00-6007-001	COMPRESSOR FEED PUMP
M3	V00-6052-008	COMPRESSOR HYDRAULIC MOTOR
F3	V00-6600-053	P1 PUMP SUCTION FILTER
OPT	OPTIONAL 005	OPTIONAL 005
Y6	V00-6100-071 + V00-6204-019	HYDRAULIC PLUS CYLINDER SOLENOID VALVE CONTROL
Y5	V00-6100-051	HYDRAULIC FAN SOLENOID VALVE CONTROL
Y4	V00-6100-052 + V00-7200-015	REELWINDERS SOLENOID VALVE CONTROL
Y3	V00-6100-050 + V00-7200-014	VACUUM-BRAKE BULL WHEEL OPENING SOLENOID VALVE
Y2	V00-6203-002	PULL REGULATION PROPORTIONAL VALVE
Y1	V00-6001-012	P1 PUMP PROPORTIONAL SOLENOID VALVE CONTROL
V5	V00-6204-010	CHECK VALVE
V4	V00-6204-011	CHECK VALVE
V3	V00-6204-010	RADIATOR BY-PASS CHECK VALVE
V2	V00-6209-001	REELWINDERS REGULATION PRESSURE VALVE
V1	V00-6200-014	PULL REGULATION SEQUENCE VALVE
Rd	V00-6610-011	HYDRAULIC OIL RADIATOR
P3	V00-6004-008	FAN RADIATOR MOTOR AND AUXILIARY EQUIPMENT FEEDING PUMP
P2	V00-6004-009	REELWINDERS EQUIPMENT FEED PUMP
P1	V00-6001-012	M1 FEED PUMP
M2	V00-6052-007	FAN RADIATOR MOTOR
M1	V00-6050-014	BULL WHEELS MOTOR
I3	V00-6300-010	REELWINDERS WORKING PRESSURE MANOMETER
I2	V00-6300-006	P1 PUMP BOOST PRESSURE MANOMETER
I1	V00-6300-020	P1 WORKING PRESSURE MANOMETER
FR1	V00-5702-009	VACUUM-BRAKE BULL WHEEL
F2	V00-6600-013	RETURN FILTER
F1	V00-6600-010	P1 PUMP SUCTION FILTER
BP4	V00-8510-072	PRESSURE TRANSDUCER

**TESMEC** Ing. Oscar  
 MODELLO AFS 404 602  
 03-11-2011  
 ~000.0 Kg  
 S02-00024